



Application Manual for Aluminum Electrolytic Capacitors for PD Fast Charging

**Capacitor Solutions,
Ask YMIN for your Applications.**



Shanghai Yongming Electronic Co., Ltd.

Website: www.ymin.com

Address: No. 258, Guangcun Road, Yangwang Economic Park,
Nanqiao Town, Fengxian District, Shanghai

Table of contents

- 01** Development Background of Aluminum Electrolytic Capacitors for PD Fast Charging
- 02** PD fast charging market requirements
- 03** Advantages of Gallium Nitride Fast Charging Dedicated Aluminum Electrolytic Capacitors
- 04** PD fast charging dedicated capacitor packaging quantity
Quantity of liquid aluminum electrolytic capacitors in packaging
Solid aluminum electrolytic capacitor packaging quantity
- 05** Dedicated for fast charging input
High-voltage liquid aluminum electrolytic capacitor
- 06** Dedicated for fast charging output
Low-voltage solid aluminum electrolytic capacitors
- 07** Wireless charging star product
Output-side dedicated low-voltage solid aluminum electrolytic capacitor
Ultra-thin solid multilayer aluminum electrolytic capacitor at the output end
- 08** Main partner brands
- 09** Complete product disassembly case

background



Back in 2018, at the request of Navitas, POWER, and Innoscience, Yungming developed miniaturized aluminum electrolytic capacitors specifically for PD fast charging. Liquid aluminum electrolytic capacitors were used on the high-voltage input side of PD fast charging, while solid aluminum electrolytic capacitors were used on the low-voltage output side. This met the urgent need for high power density and miniaturization in PD fast charging products. Yungming also developed high-capacity, small-size, and highly reliable products compatible with gallium nitride (GaN). These products gained high market recognition and favor after their launch. With technological advancements, Yungming will continue to innovate and launch even smaller, more reliable aluminum electrolytic capacitors. We support the innovation and upgrading of our customers' products, ensure their stable operation, and guarantee a superior user experience!



PD fast charging market requirements

The market demands fast charging: high power and small size.

Fast Charging Systems		Yongming Aluminum Electrolytic Capacitors								
Module Size becomes smaller	Module Power becomes larger	Transformer	Power Components	Power Components	Topology	33μF 400V Liquid	680μF 25V Liquid	1000μF 25V Solid	680μF 35V	1000μF 35V
Large ↓	5W, 8W, 18W, 27W ↓	Wire-Wound Transformer ↓	Second Generation GaAs, InP Comiconductors ↓	Planar Layout ↓	Planar Layout	10x25 10x20	10x20 8x20	10x16 10x14	8x16 ↓	
Small	45W, 65W, 100W, 120W	Planar Transformer	Planar Transformer	Third Generation GaN, SiC Wide Bandgap Semiconductors	Volumetric Layout	10x15	8x12 6.3x15	8x16 8x12	6.3x20	8x18

65W GaN PD fast charging solution design diagram

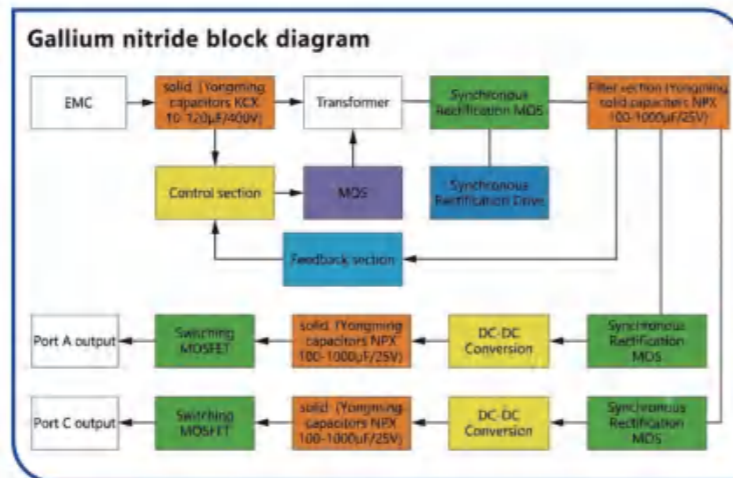
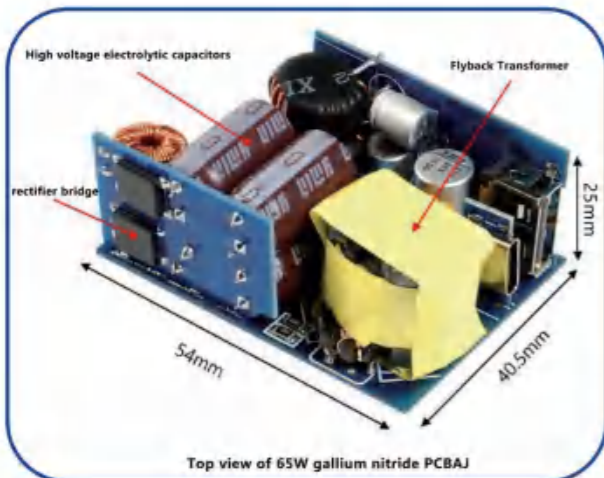

Advantages of capacitor products

Input Side: High-Voltage Liquid Aluminum Electrolytic Capacitors

Ymin Advantages

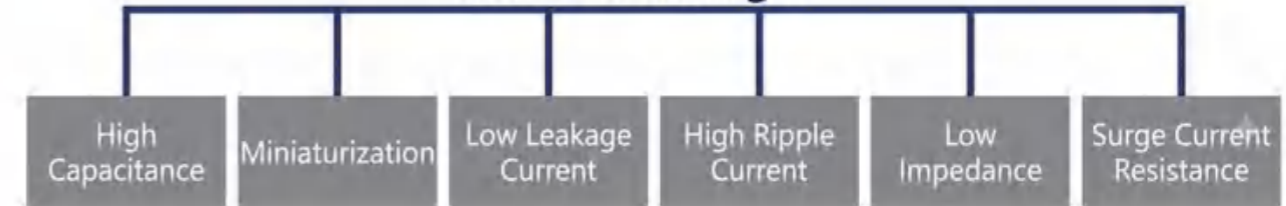

The gallium nitride (GaN) fast charging market is booming. In conjunction with the high power density performance of GaN fast chargers, Yung Ming has developed and produced the liquid high voltage, high capacity, miniaturized KCX series. It uses mature patented process technology, adopts new materials, and breaks through the capacitor technology barrier. The overall failure rate is controlled at 15PPM, achieving the best consistency and the most stable reliability.

Reliability Guarantee

Material Technology	Process Technology	Equipment & Fixtures
High specific ratio, ultra-thin anode foil winding method (Yongming Technology)	Core pack winding limit length management method (Yongming Technology)	Miniature capacitor specific winding needle technical standard (Patent)
Lightning strike resistant guide pin design (Joint R&D)	Core pack true roundness management method (Japanese Technology)	Punching/Riveting needle technical standard (Joint R&D)
High specific ratio, water-hydration resistant cathode foil (Joint R&D)	Core pack small margin winding process (Yongming Technology)	Small margin foil feeding stage and paper tank (Yongming Technology)
Low viscosity, high boiling point, high spark voltage anhydrous electrolyte (Yongming Formula and Technology)	Aluminum foil burr management and control technology (Yongming Technology)	Precision mold set (Joint R&D)
High voltage resistant, high strength electrolytic paper (European Imported)	Ultra-miniature aluminum electrolytic capacitor assembly and packaging process (Yongming Technology, Yongming Patent)	Custom assembly sealing needle, waistband wheel (Patent)
Medical-grade sealing capability rubber bung (Joint R&D)	High voltage capacitor low leakage current aging process (Yongming Technology)	High voltage capacitor aging specific fixture (Yongming Technology)
	Surge resistant riveting process (Patent)	Ultra-narrow strip aluminum foil slitting (Joint R&D)

Yongming capacitors have passed the stringent testing requirements of well-known brands. The specific testing conditions are as follows:

Aging Test	Switching Test
Input 110Vac, full output load, aging for 4 hours	Input 220Vac, full output load, switching cycle test steps are as follows:
Input 220Vac, full output load, aging for 2 hours	1) Turn on and work for 4 minutes, then power off;
	2) Then turn on and work for 9 minutes, then power off;
	3) Then turn on and work for 4 minutes, then power off;
	4) Then turn on and work for 9 minutes, then power off;
	5) Then turn on and work for 4 minutes, then power off;
	Each cycle has 5 on/off impulses, each for 30 minutes, repeating af 120

YMIN launches solid aluminum electrolytic capacitors resistant to switching shocks

Output Side: Low Voltage Solid Aluminum Electrolytic Capacitors

Ymin Advantages

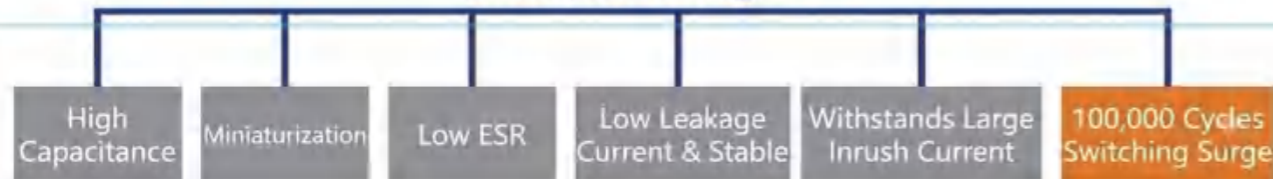

Gallium nitride (GaN) PD fast charging achieves high power output through high voltage and high current, thus enabling rapid charging. Its output voltage can reach up to 21V, and its output current can reach 5A. Therefore, the output filter capacitors are typically 25V solid-state capacitors with large capacitance and low ESR. Sufficiently large capacitance ensures DC support, and sufficiently low ESR guarantees filtering effectiveness. However, conventional 25V solid-state aluminum electrolytic capacitors have a problem: insufficient resistance to switching surges. Test data and market feedback indicate that after repeated switching charge and discharge cycles (including but not limited to frequent plugging and unplugging during fast charging), conventional 25V solid-state aluminum electrolytic capacitors exhibit significant capacitance decay, accompanied by a rapid increase in ESR. This leads to a deterioration in the DC support capability of the solid-state capacitor, resulting in a significant reduction in fast charging speed—fast charging is no longer truly fast! Furthermore, the rapid increase in ESR causes increased output ripple during fast charging, leading to numerous negative impacts. Since fast charging inevitably involves frequent plugging and unplugging, it is essential that fast charging can withstand frequent charge and discharge cycles. Therefore, we recommend the solid-state aluminum electrolytic capacitors developed by Shanghai Yongming Electronics, which are resistant to frequent switching charge and discharge cycles. Their performance characteristics are as follows:

Excellent resistance to switching charge and discharge.

Test Item	Test Condition	Yongming 25V Surge-Resistant Solid Capacitor	Conventional 25V Solid Capacitor
Standard Switching Surge Test for Aluminum Electrolytic Capacitors	Under 1.15 times rated working voltage, 30 seconds charging, 5 minutes 30 seconds discharging for one cycle, test for 1000 cycles	1. Capacitance: Decay ratio -1% approx; 2. ESR: Virtually unchanged	1. Capacitance: Decay ratio -15% ~ -20%; 2. ESR: Rises 3~5 mΩ
High-Demand Switching Test for Fast-Charging Device (10,000 times)	Under 1.15 times rated working voltage, 5 seconds charging, 5 seconds discharging for one cycle, test for 10000 cycles	1. Capacitance: Decay ratio -3% approx; 2. ESR: Virtually unchanged	1. Capacitance: Decay ratio -20% ~ -30%; 2. ESR: Rises 6~10 mΩ
Switching Test for Fast-Charging Device (100,000 times)	Under 1.15 times rated working voltage, 1 second charging, 1 second discharging for one cycle, test for 100000 cycles	1. Capacitance: Decay ratio -12% approx; 2. ESR: Rises 2~3 mΩ	1. Capacitance: Decay ratio -40% ~ -80%; 2. ESR: Rises dramatically, can increase to Ω level in severe cases
To be continued...			

Packaging quantity

■ Diameter < 16mm, Height < 30mm

Standard for the quantity of packaging products with long legs and those with more than 5 trimmed legs

External dimensions	PCS/bag	bag/each small box	box/each large carton	PCS/per large box
6.3*7~9	1000	8000	4	32000
6.3*10~14	1000	4000	6	24000
6.3*15~19	1000	5000	4	20000
6.3*20	750	3750	4	15000
7*15~20	500	3000	4	12000
8*10~12	500	5000	4	20000
8*13	500	4000	4	16000
8*14~18	500	3000	4	12000
8*19~23	500	2500	4	10000
8*24~25	400	1600	4	6400
10*7~12.5	500	3000	4	12000
10*13~14	500	2500	4	10000
10*15~18	500	2000	4	8000
10*19~21	250	1750	4	7000
10*22~25	250	1000	6	6000
12.5*12.5~15	200	1200	6	7200
12.5*16~17	125	1000	6	6000
12.5*18~20	100	800	6	4800
12.5*21~25	100	800	4	3200

Packaging quantity standard for trimmed tips less than 5mm

External dimensions	PCS/bag	bag/each small box	box/each large carton	PCS/per large box
6.3*7~10	1000	8000	4	32000
6.3*11~13	1000	7000	4	28000
6.3*15~17	1000	5000	4	20000
6.3*18~19	750	4500	4	18000
6.3*20	750	3750	4	15000
7*11	1000	5000	4	20000
7*15~20	500	3000	4	12000
8*10~13	500	4000	3	12000
8*14	500	3000	3	9000
8*15~16	500	4000	2	8000
8*17~20	350	2800	2	5600
8*21~25	250	2000	2	4000
10*7~11	500	3000	4	12000
10*12~14	500	2500	4	10000
10*15~18	500	2000	4	8000
10*19~25	250	1500	4	6000
12.5*12.5~19	200	1600	4	6400
12.5*20~25	150	1200	4	4800

Packaging quantity standard for 90-degree bending

External dimensions	PCS/bag	bag/each small box	box/each large carton	PCS/per large box
6.3*9~14	1000	8000	4	32000
6.3*14~15	750	6000	2	12000
6.3*20	500	4000	2	8000
7*15~20	500	4000	2	8000
8*14及以下	500	4000	4	16000
8*15~20	350	2800	2	5600
8*21~25	250	2000	2	4000
10*7~14	350	2800	2	5600
10*15~25	250	2000	2	4000
12.5*10~25	150	1200	4	4800

■ 8mm ≤ Diameter < 16mm, Height ≥ 30mm
Diameter ≥ 16mm, Full Height

Product Dimensions		Long lead products			Lead wire processed products		
diameter	high	Bagged	Boxed	boxed	Bagged	Boxed	boxed
Φ8	30~35	350	1400	5600	350	1400	5600
	40~45	300	1200	4800	300	1200	4800
Φ10	30	150	1200	4800	150	1200	4800
	35	150	900	3600	150	900	3600
	40~45	150	750	3000	150	750	3000
	50~55	150	600	2400	150	600	2400
Φ12.5	30	100	800	3200	100	800	3200
	35~40	100	600	2400	100	600	2400
	45~50	100	400	1600	100	400	1600
Φ16	30	55	110	880	55	110	880
	35.5~36	50	100	800	50	100	800
	45~50	50	100	600	50	100	600
Φ18	30~36	51	102	612	51	102	612
	45	42	84	504	42	84	504

Solid leaded package quantity

Product Dimensions		Long lead products			Lead wire processed products			Braided items	
diameter	high	Bagged	Boxed	boxed	Bagged	boxed	Boxed	Boxed	boxed
Φ5	7~12	1000	6000	36000	1000	6000	36000	2100	21000
Φ6.3	7以下	1000	10000	60000	1000	10000	60000	-	-
	7~9	1000	8000	32000	1000	8000	32000	1700	17000
	10~12	1000	4000	24000	1000	4000	24000	1700	17000
	15	1000	5000	20000	1000	5000	20000	1700	17000
	20	750	4500	18000	750	4500	18000	1700	17000
Φ8	10	500	6000	24000	500	6000	24000	1000	10000
	11~14	500	4000	16000	500	4000	16000	1000	10000
	16~18	500	3000	12000	500	3000	12000	1000	10000
Φ10	14	500	2500	10000	500	2500	10000	672	6720
	16	500	2000	8000	500	2000	8000	672	6720

*Note: The quantity of lead wire processed products packaged is a reference value, and the actual quantity packaged shall prevail.

Solid surface mount packaging

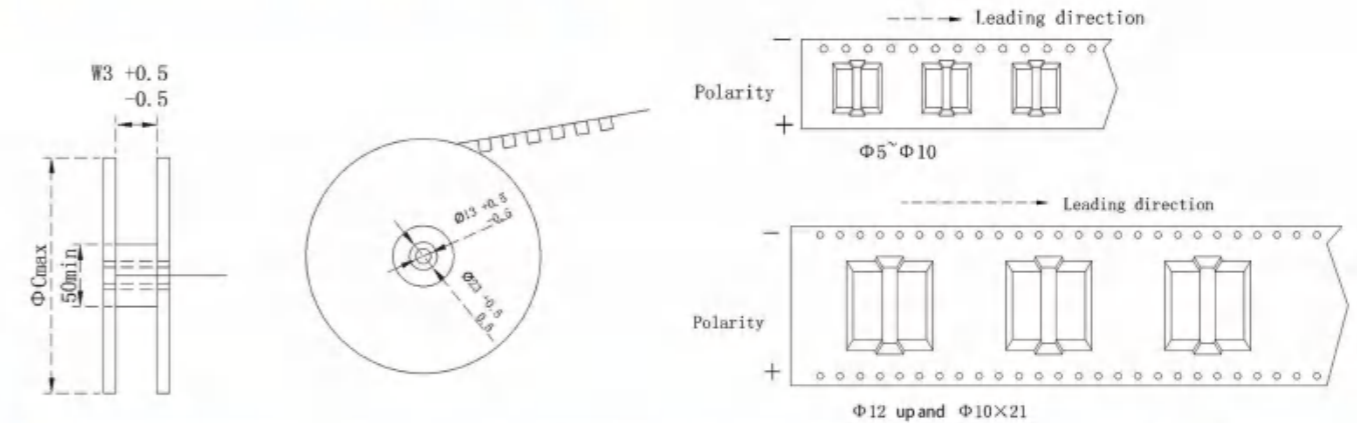

尺寸	W3 (mm)	ΦC (mm)	Material tray / (pcs)	Inner box		Outer box	
				Number of trays (pieces)	Maximum packaging quantity: pcs/box	Number of inner boxes (pieces)	Maximum packaging quantity: pcs/box
Φ5×5.4~5.8, Φ5×5.7	14	382	1200	8	9600	3	28800
Φ5×7.7~7.9, Φ5×8.5	18	382	900	6	5400	3	16200
Φ5×9.5, Φ5×10, Φ5.5×9	18	382	700	6	4200	3	12600
Φ5×11, Φ5×12, Φ5×13	18	382	500	6	3000	3	9000
Φ5×15.5, Φ5.5×15.5	18	382	350	6	1750	3	5250
Φ6.3×3.95, Φ6.3×4.5	18	382	1500	6	9000	3	27000
Φ6.3×5.4~5.8, Φ6.3×6.1	18	382	1200	6	7200	3	21600
Φ6.3×7.7, Φ6.3×8	18	382	900	6	5400	3	16200
Φ6.3×8.5, Φ6.3×9	18	382	800	6	4800	3	14400
Φ6.3×9.5, Φ6.3×10	18	382	700	6	4200	3	12600
Φ6.3×11, Φ6.3×12, Φ6.3×13	18	382	500	6	3000	3	9000
Φ6.3×16.5	18	382	350	6	2100	3	6300

KCM NEW

- ◆ Ultra-small size, high temperature and high pressure resistance, long lifespan
- ◆ 3000 hours at 105°C
- ◆ Lightning protection, low leakage current, high frequency and low impedance, high ripple resistance



■ Main technical parameters

project	characteristic	
Operating Temperature Range	- 40~+105°C	
Nominal Voltage Range	400~450V	
Capacity Tolerance	±20% (25±2°C 120Hz)	
Leakage Current (μA)	400~500WV $I \leq 0.015CV + 10(\mu A)$ C: Nominal capacitance (μF) V: Rated voltage (V) Readings taken over 2 minutes	
Loss Tangent (25 ± 2° C 120Hz)	Rated voltage (V) 400 450	
	tg δ 0.15 0.18	
Temperature Characteristics (120Hz)	Rated voltage (V) 400 450	
	Impedance ratio Z(-40°C)/Z(20°C) 7 9	
Durability	After being stored at 105°C for 1000 hours and then placed at room temperature for 16 hours for testing at a test temperature of 25±2°C, the capacitor performance should meet the following requirements.	
	Capacity change rate	Within ±20% of the initial value
	Loss tangent	Below 200% of the specified value
	Leakage current	Below the specified value
Load life	≤Φ6.3	2000小时
	≥Φ8	3000小时
High Temperature Storage	After being stored at 105°C for 1000 hours and then placed at room temperature for 16 hours for testing at a test temperature of 25±2°C, the capacitor performance should meet the following requirements.	
	Capacity change rate	Within ±20% of the initial value
	Loss tangent	Below 200% of the specified value
	Leakage current	Below 200% of the specified value

■ Product dimension drawing (unit: mm)

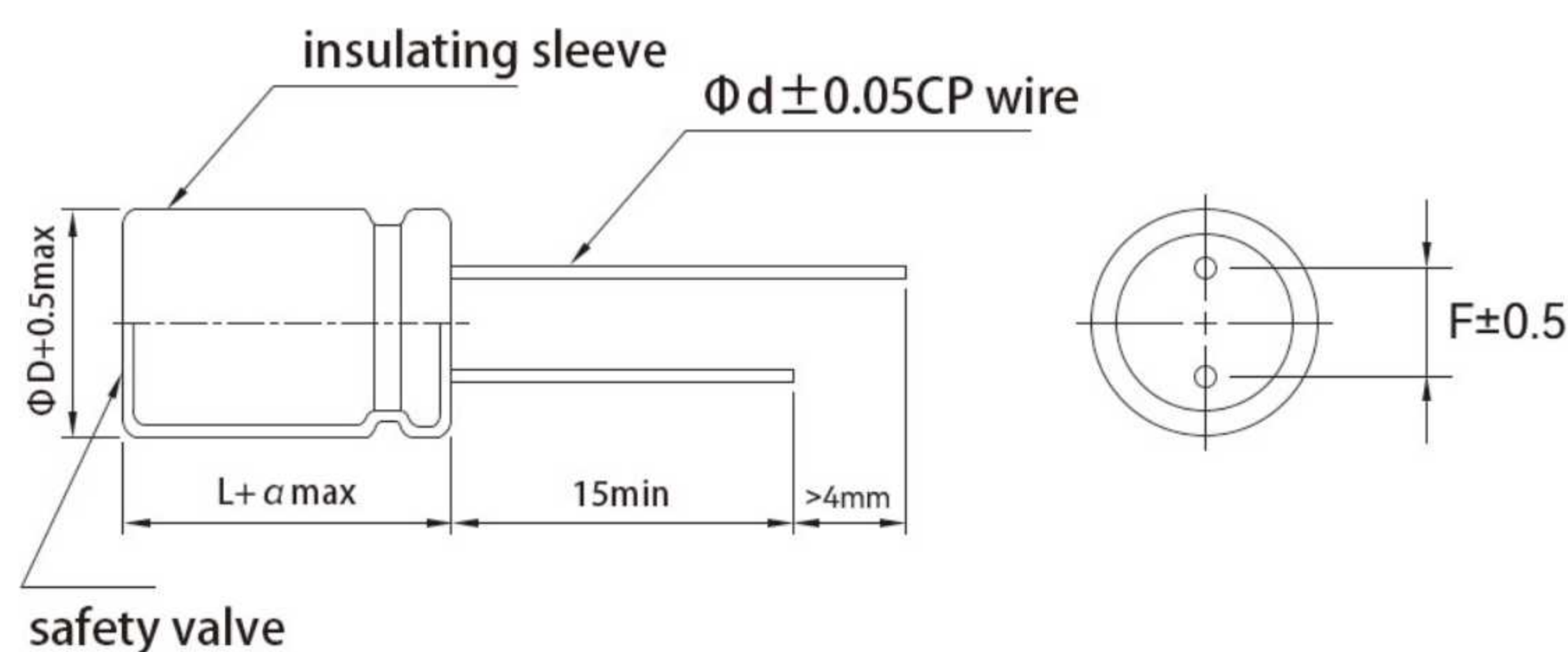

Note: Products ≥ Φ6.3 have a safety valve.

D	5	6.3	7	8	10	12.5~13	12.5~13(h≥30)	14.5	16	18
d	0.5	0.5	0.6	0.6	0.6	0.7	0.6	0.8	0.8	0.8
F	2.0	2.5	3.5	3.5	5.0	5.0	5.0	7.5	7.5	7.5
α	L<20 α=±1.0					L≥20 α=±2.0				

■ Frequency correction factor

Frequency (Hz)	50	120	1K	10K~50K	100K
coefficient	0.40	0.50	0.80	0.90	1.00



KCM

■ List of Standard Products

Voltage (V)	400			450		
project Capacity (μF)	Dimensions: ΦD×L (mm)	Impedance (Ωmax/100kHz 25±2°C)	Ripple current (mA r.m.s / 105°C 120Hz)	Dimensions: ΦD×L (mm)	Impedance (Ωmax/100kHz 25±2°C)	Ripple current (mA r.m.s / 105°C 120Hz)
8.2	7*10	6.60	135			
12	6.3*18	7.80	218			
	8*10	5.40	260			
	8*11	5.40	260			
15	6.3*20	4.20	255			
	7*15	4.40	240			
	8*11	5.50	281			
	8*12	3.7	288			
18	7*18	4.00	255			
	8*13	4.00	278			
	8*14	3.70	314			
	10*11	4.00	335			
22	7*20	4.00	260	8*18	3.10	319
	8*15	4.00	305	10*14	6.08	305
	8*16	3.80	406			
	10*12.5	3.20	365			
27	8*18	4.05	355	10*18	5.48	375
	10*14	3.10	380			
	12.5*13	5.48	380			
33	8*20	2.80	390	10*18	5.48	390
	8*25	3.10	389			
	10*15	2.50	478			
	10*16	2.80	475			
	12.5*14	2.50	502			
39	8*30	2.50	440			
	10*17	2.50	523			
	10*18	2.50	523			
	10*19	2.60	550			
	12.5*16	2.50	562			
47	8*30	2.50	440			
	10*20	2.30	602			
	12.5*18	2.18	668			
	13*17	2.10	668			
56	8*35	1.85	575			
	13*18	2.20	658			
	13*19	1.70	825			
68	10*30	1.55	785	10*40	1.60	890
	13*20	1.50	825	18*16	1.60	870
	16*16	1.58	885			

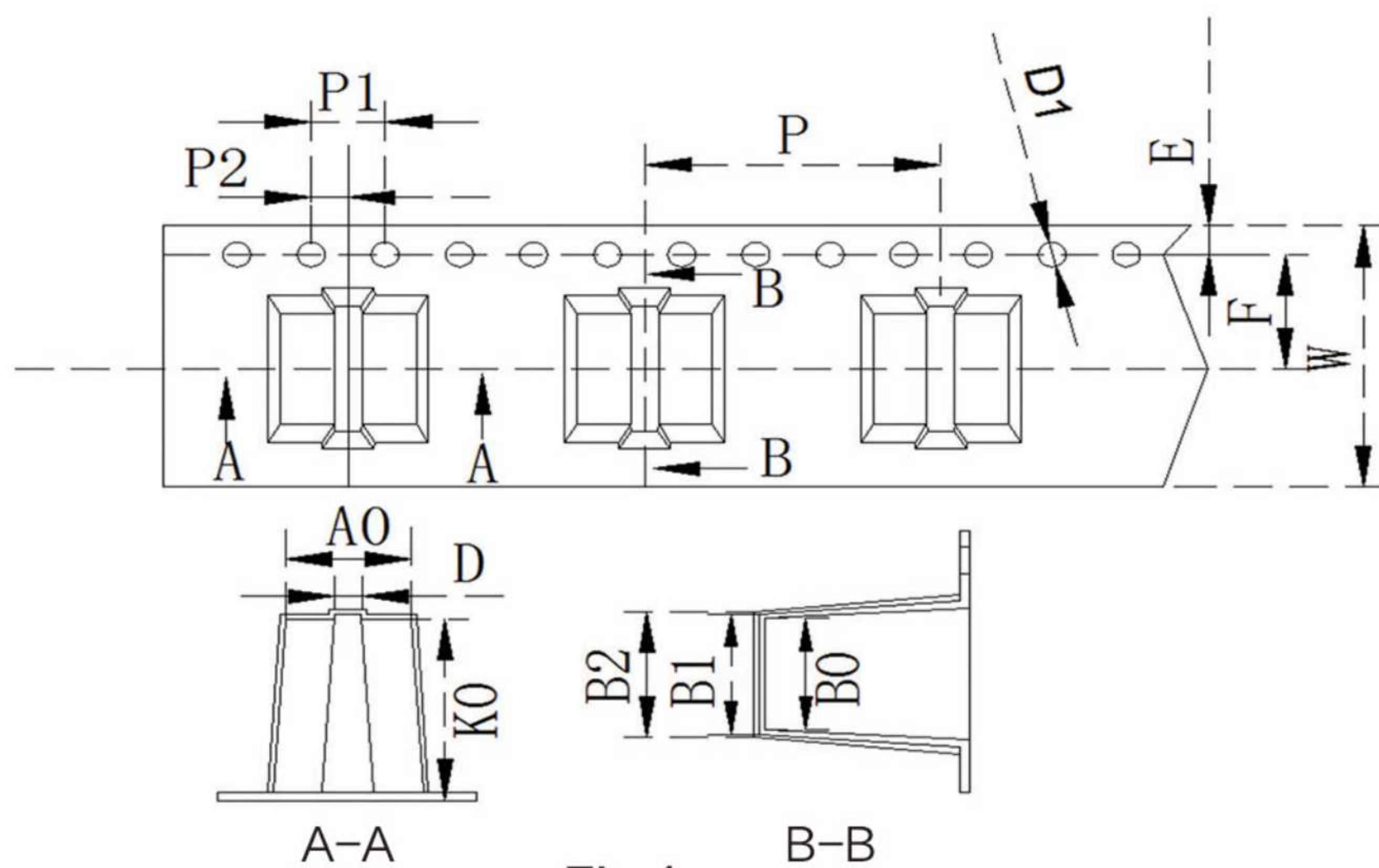
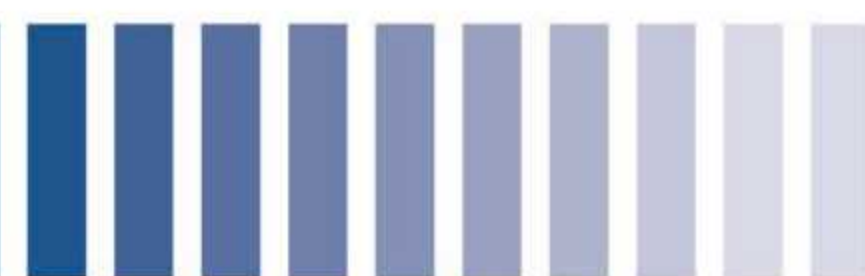

Fig.1

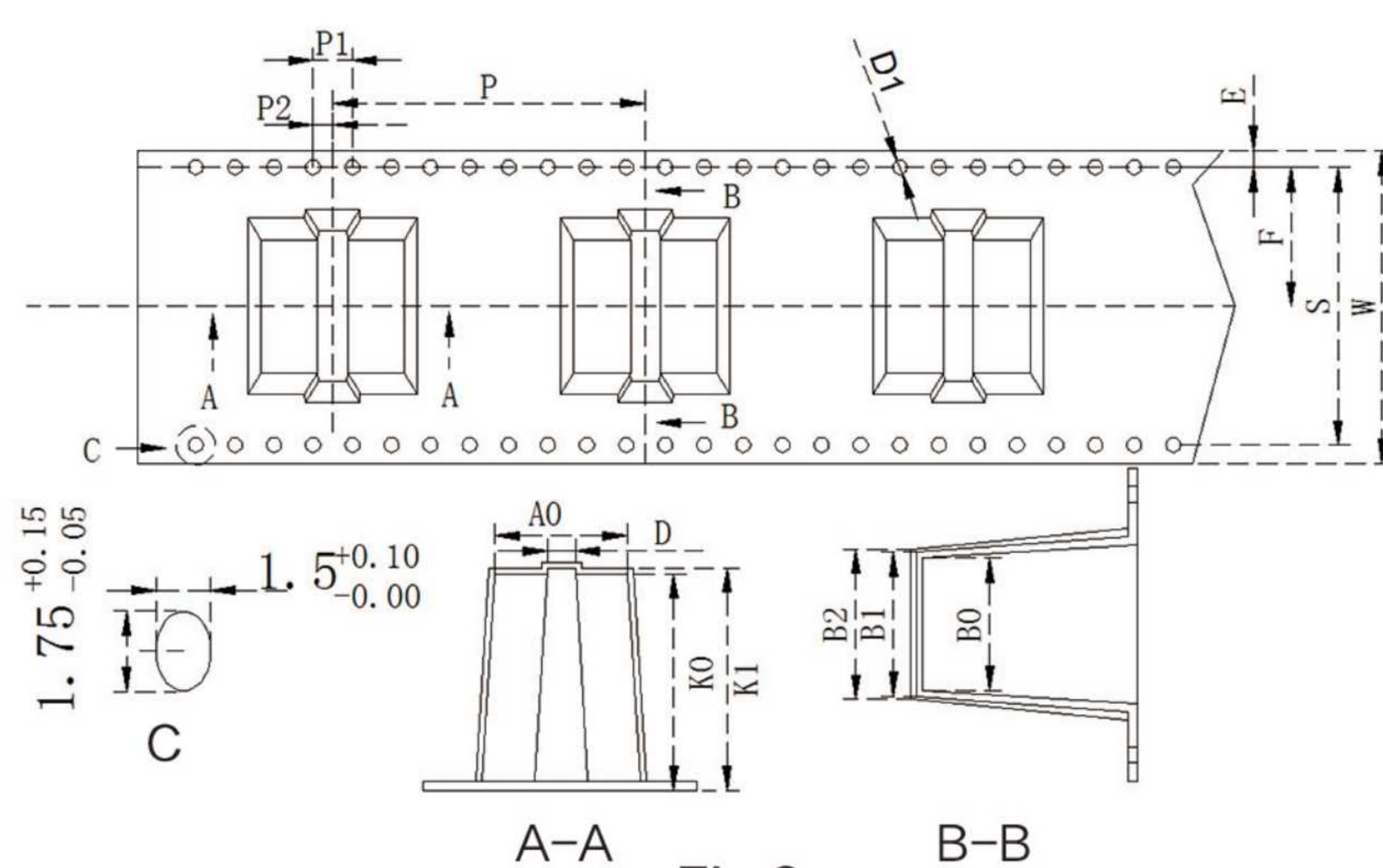
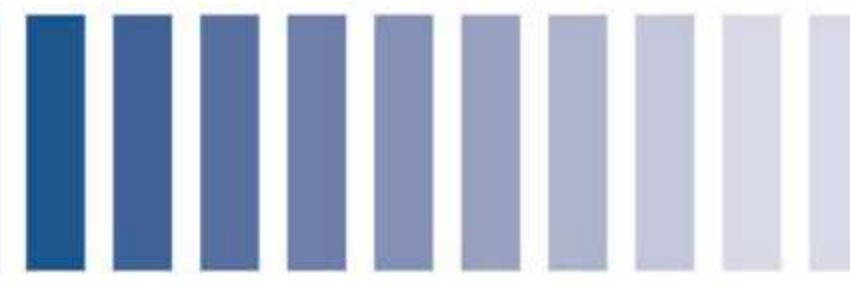

Fig.2

unit:

Product Name	standard	W	A0	B0	B1	B2	D	D1	E	F	K0	K1	P	t	
Φ4×3.95		12	4.6	4.6	5.2	5.9	1.6	1.5	1.75	5.5	4.6	/	8.0	0.4	FIG.1
Φ4×5.4~5.8		12	4.6	4.6	5.2	5.9	1.6	1.5	1.75	5.5	6.3	/	8.0	0.4	
Φ5×3.95		12	5.7	5.7	6.3	7.1	1.6	1.5	1.75	5.5	4.6	/	12.0	0.4	
Φ5×5.4~5.8		12	5.7	5.7	6.3	7.1	1.6	1.5	1.75	5.5	5.8	/	12.0	0.4	
Φ5×7.7~7.9		16	5.7	5.7	6.3	7.1	1.6	1.5	1.75	7.5	8.3	8.6	12.0	0.4	
Φ5×10		16	5.7	5.7	6.3	7.1	1.6	1.5	1.75	7.5	9.6	9.9	12.0	0.5	
Φ5×12		16	5.7	5.7	6.3	7.1	1.6	1.5	1.75	7.5	11.7	12.0	12.0	0.5	
Φ6.3×3.95		16	7.0	7.0	8.0	8.7	1.6	1.5	1.75	7.5	4.6	/	12.0	0.4	
Φ6.3×5.4~5.8		16	7.0	7.0	8.0	8.7	1.6	1.5	1.75	7.5	5.9	/	12.0	0.4	
Φ6.3×7.7		16	7.0	7.0	8.0	8.7	1.6	1.5	1.75	7.5	8.3	8.6	12.0	0.4	
Φ6.3×7.7不开槽		16	7.0	7.0	8.0	8.7	1.6	1.5	1.75	7.5	8.1	/	12.0	0.4	
Φ6.3×10		16	6.8	6.8	8.1	8.7	1.6	1.5	1.75	7.5	10	10.3	12.0	0.5	
Φ6.3×12		16	6.8	6.8	8.1	8.7	1.6	1.5	1.75	7.5	11.7	12.0	12.0	0.5	
Φ8×5.7~6.2		24	8.7	8.7	9.9	11.3	2.0	1.5	1.75	7.5	7.2	/	16.0	0.4	
Φ8×7.7~7.9		24	8.7	8.7	9.9	11.3	2.0	1.5	1.75	11.5	8.3	8.6	16.0	0.4	
Φ8×10		24	8.7	8.7	9.9	11.3	2.0	1.5	1.75	11.5	10.7	11.0	16.0	0.4	
Φ8×11~12.5		24	8.7	8.7	9.9	11.3	2.0	1.5	1.75	11.5	12.7	13.0	16.0	0.4	
Φ8×13.5~14.5		24	8.7	8.7	9.9	11.3	2.0	1.5	1.75	11.5	13.7	14.0	16.0	0.5	
Φ8×15.5~16.5		24	8.7	8.7	9.9	11.3	2.0	1.5	1.75	11.5	17.2	17.5	16.0	0.5	
Φ8×20.5		32	8.7	8.7	9.9	11.3	2.0	1.5	1.75	14.2	21.2	21.5	24.0	0.5	
Φ10×5.7~6.9		24	10.7	10.7	11.9	13.3	2.0	1.5	1.75	11.5	7.5	/	16.0	0.4	
Φ10×7.7~8.4		24	10.7	10.7	11.9	13.3	2.0	1.5	1.75	11.5	8.7	9.0	16.0	0.4	
Φ10×10		24	10.7	10.7	11.9	13.3	2.0	1.5	1.75	11.5	10.7	11.0	16.0	0.4	
Φ10×13~14.5		24	10.7	10.7	11.9	13.3	2.0	1.5	1.75	11.5	14.7	15.0	16.0	0.5	
Φ10×16~16.5		24	10.7	10.7	11.9	13.3	2.0	1.5	1.75	11.5	16.7	17.0	16.0	0.5	
Φ10×21		32	10.7	10.7	11.9	13.3	2.0	1.5	1.75	14.2	21.2	21.5	24.0	0.5	
Φ12.5×13.5~14.5		32	13.4	13.4	16.0	17.4	2.5	1.5	1.75	14.2	14.2	14.5	24.0	0.4	
Φ12.5×16.5~17		32	13.4	13.4	16.0	17.4	2.5	1.5	1.75	14.2	17.2	17.5	24.0	0.5	
Φ12.5×21		32	13.4	13.4	16.0	17.4	2.5	1.5	1.75	14.2	21.2	21.5	24.0	0.5	
Φ16×16.5~17		44	17.5	17.5	22.1	23.5	2.5	1.5	1.75	20.2	17.2	17.5	28.0	0.5	
Φ16×21~21.5		44	17.5	17.5	22.1	23.5	2.5	1.5	1.75	20.2	21.7	22.0	28.0	0.5	
Φ18×16.5~17		44	19.2	19.2	23.0	24.4	3.3	1.5	1.75	20.2	17.2	17.5	32.0	0.5	
Φ18×21~21.5		44	19.2	19.2	23.0	24.4	3.3	1.5	1.75	20.2	21.7	22.0	32.0	0.5	

FIG.2



KCM

■ List of Standard Products

Voltage (V)	400			450		
project Capacity (μF)	Dimensions: ΦD×L (mm)	Impedance (Ωmax/100kHz 25±2°C)	Ripple current (mA r.m.s / 105°C 120Hz)	Dimensions: ΦD×L (mm)	Impedance (Ωmax/100kHz 25±2°C)	Ripple current (mA r.m.s / 105°C 120Hz)
82	10*35	1.40	860	16*20	1.45	1000
	16*18	1.40	960			
	18*16	1.40	960			
100	10*40	1.35	1000	18*20	1.38	1178
	12.5*30	1.35	1000			
	16*20	1.35	1050			
	18*19	1.35	1080			
120	10*50	1.25	1220			
	12.5*35	1.25	1180			
	13*30	1.25	1220			
	16*25	1.20	1250			
	18*20	1.20	1250			
150	16*30	1.15	1450	13*50	1.05	1450
	18*25	1.15	1420			
180	18*25	0.90	1560			



KCX

◆ Ultra-compact size, high voltage, dedicated product for direct charging and fast charging power supplies

◆ 2000~3000 hours of operation at 105°C

◆ Lightning resistant, low leakage current (low standby power consumption), high ripple current, high frequency and low impedance

◆ RoHS compliant



Main technical parameters

project	characteristic										
Operating Temperature Range	- 40~+105°C										
Nominal Voltage Range	400~500V										
Capacity Tolerance	±20% (25±2°C 120Hz)										
Leakage Current (μA)	400~500WV $I \leq 0.015CV + 10$ (μA) C: Nominal capacitance (μF) V: Rated voltage (V) Readings taken over 2 minutes										
Loss Tangent (25 ± 2° C 120Hz)	<table border="1"> <tr> <td>Rated voltage (V)</td> <td>400</td> <td>420</td> <td>450</td> <td>500</td> </tr> <tr> <td>tg δ</td> <td>0.15</td> <td>0.15</td> <td>0.18</td> <td>0.20</td> </tr> </table>	Rated voltage (V)	400	420	450	500	tg δ	0.15	0.15	0.18	0.20
	Rated voltage (V)	400	420	450	500						
tg δ	0.15	0.15	0.18	0.20							
For nominal capacities exceeding 1000 μF, the loss tangent increases by 0.02 for every additional 1000 μF.											
Temperature Characteristics (120Hz)	<table border="1"> <tr> <td>Rated voltage (V)</td> <td>400</td> <td>420</td> <td>450</td> <td>500</td> </tr> <tr> <td>Impedance ratio Z(-40°C)/Z(20°C)</td> <td>7</td> <td>7</td> <td>9</td> <td>9</td> </tr> </table>	Rated voltage (V)	400	420	450	500	Impedance ratio Z(-40°C)/Z(20°C)	7	7	9	9
	Rated voltage (V)	400	420	450	500						
Impedance ratio Z(-40°C)/Z(20°C)	7	7	9	9							
Durability	After being stored at 105°C for 1000 hours and then placed at room temperature for 16 hours for testing at a test temperature of 25±2°C, the capacitor performance should meet the following requirements.										
	Capacity change rate	Within ±20% of the initial value									
	Loss tangent	Below 200% of the specified value									
	Leakage current	Below the specified value									
	Load life	<table border="1"> <tr> <td>$\leq \Phi 6.3$</td> <td>2000h</td> </tr> <tr> <td>$\geq \Phi 8$</td> <td>3000h</td> </tr> </table>	$\leq \Phi 6.3$	2000h	$\geq \Phi 8$	3000h					
$\leq \Phi 6.3$	2000h										
$\geq \Phi 8$	3000h										
High Temperature Storage	After being stored at 105°C for 1000 hours and then placed at room temperature for 16 hours for testing at a test temperature of 25±2°C, the capacitor performance should meet the following requirements.										
	Capacity change rate	Within ±20% of the initial value									
	Loss tangent	Below 200% of the specified value									
	Leakage current	Below 200% of the specified value									

Product dimension drawing (unit: mm)

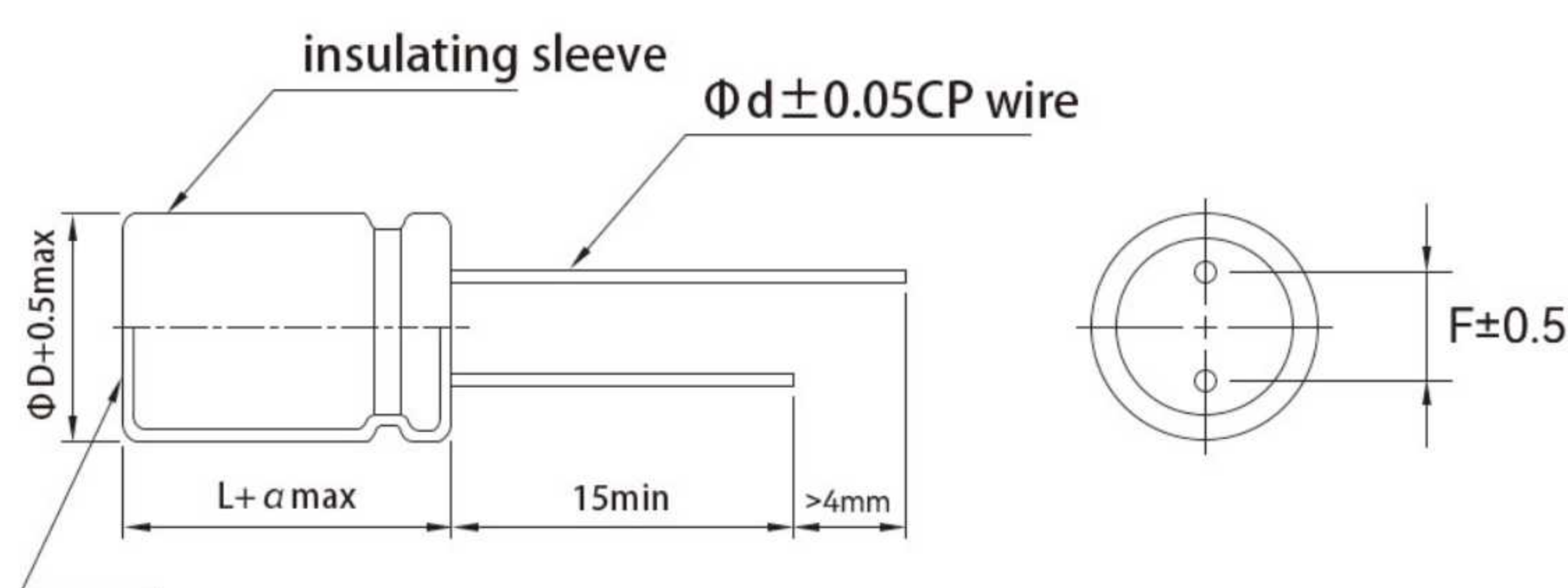

safety valve

Note: Products $\geq \Phi 6.3$ have a safety valve.

D	5	6.3	7	8	10	12.5~13	12.5~13(h \geq 30)	14.5	16	18
d	0.5	0.5	0.6	0.6	0.6	0.7	0.6	0.8	0.8	0.8
F	2.0	2.5	3.5	3.5	5.0	5.0	5.0	7.5	7.5	7.5
α	L<20 α=±1.0					L \geq 20 α=±2.0				

Frequency correction factor

Frequency (Hz)	50	120	1K	10K~50K	100K
coefficient	0.40	0.50	0.80	0.90	1.00

KCX

List of Standard Products

Voltage (V)	400			420			450			500		
project	Dimensions: ΦD×L (mm)	Impedance (Ωmax/100kHz 25±2°C)	Ripple current (mA r.m.s / 105°C 120Hz)	Dimensions: ΦD×L (mm)	Impedance (Ωmax/100kHz 25±2°C)	Ripple current (mA r.m.s / 105°C 120Hz)	Dimensions: ΦD×L (mm)	Impedance (Ωmax/100kHz 25±2°C)	Ripple current (mA r.m.s / 105°C 120Hz)	Dimensions: ΦD×L (mm)	Impedance (Ωmax/100kHz 25±2°C)	Ripple current (mA r.m.s / 105°C 120Hz)
Capacity (μF)												
4.7	6.3×12	9.60	116				8×9	15.7	111	6.3×16	17.5	80
							8×10	15.7	111	8×10	17.5	80
							8×12	27	128			
							6.3×13	18.6	90			
							6.3×16	15.7	111			
6.8	6.3×13	8.40	128				8×11.5	12.80	111	10×10	15.30	88
							10×10	12.80	128			
8.2	6.3×15	7.50	171				8×13	9.27	163	10×10	11.13	110
10	7×13	5.40	190				8×12	5.40	163	10×13	9.85	145
	8×10	5.40	190				8×13	9.27	163			
							8×15	8.21	190			
							8×16	8.21	190			
							10×11	8.21	190			
							10×16	9.50	205			
12	8×11	4.20	200				8×15	8.21	190			
	8×13	4.20	230				10×11	8.21	190	10×13.5	7.66	206
							10×13	6.38	228			
15	7×19	4.00	250				8×17	5.78	230			
	8×13	4.20	230				8×18	5.78	230			
	8×15	4.00	260	8×15	6.08	250	10×12	3.20	228	10×15	7.30	220
							10×13	6.38	228			
							10×13.5	6.08	251			
							10×15	5.78	260			
18	8×15	4.00	260				8×17	3.10	230			
	8×17	3.20	295	8×17	3.20	285	8×18	5.78	230	10×17	6.78	240
							8×20	5.78	251			
							10×14	6.08	251			
							10×15	5.78	295			
							12.5×12.5	5.48	295			
22	8×18	3.10	314	10×15	5.78	314	8×18	3.10	319	12.5×17	5.65	312
	10×13.5	3.10	314				8×20	5.48	290			
							8×21	5.48	290			
							8×25	4.58	314			
							10×17	5.48	314			
							12.5×13	5.48	314			
							12.5×14	5.48	314			
							13×14	3.00	314			



KCX

■ List of Standard Products

Voltage (V)	400			420			450			500		
project	Dimensions: ΦD×L (mm)	Impedance (Ωmax/100kHz 25±2°C)	Ripple current (mA r.m.s / 105°C 120Hz)	Dimensions: ΦD×L (mm)	Impedance (Ωmax/100kHz 25±2°C)	Ripple current (mA r.m.s / 105°C 120Hz)	Dimensions: ΦD×L (mm)	Impedance (Ωmax/100kHz 25±2°C)	Ripple current (mA r.m.s / 105°C 120Hz)	Dimensions: ΦD×L (mm)	Impedance (Ωmax/100kHz 25±2°C)	Ripple current (mA r.m.s / 105°C 120Hz)
Capacity (μF)												
27	8×20	3.00	330				8×25	4.58	314			
	10×15	3.00	370	10×18	2.50	330	10×18	5.48	350	10×23	5.47	348
							10×19	4.56	350			
							10×20	4.56	370			
							10×25	4.56	370			
33							12.5×17	4.56	440			
	8×25	3.00	420				10×20	2.50	370			
	10×18	2.50	440	10×20	3.50	370	10×25	4.56	400	12.5×20	4.28	400
	12.5×16	2.50	440				10×35	3.26	440			
							13×17	2.18	440			
39							13×18	4.26	314			
	10×21	2.50	520				12.5×19	4.56	314			
	13×17	2.18	480	13×18	2.98	515	13×17	2.50	680			
							13×19	1.98	500			
47							13×20	2.0	314			
	10×25	2.18	560	13×17	1.98	668	10×45	2.71	616	16×20	3.25	560
	13×18	1.98	515				12.5×25	3.84	738			
							13×20	2.25	920			
							13×21.5	2.00	570			
56							14.5×16	2.40	900			
	12.5×24	1.40	738				12.5×30	2.26	620			
	13×17	1.98	560	13×20	2.05	1000	13×23	2.00	1020			
	13×20	1.90	738	14.5×16	2.00	1000	14.5×20	2.20	950			
68	18×16	1.40	1000									
	12.5×30	1.40	1000				10×50	1.64	1000			
	13×20	1.90	1050	13×23	1.80	1100	13×25	1.80	1050			
	14.5×16	1.60	1150	14.5×20	1.80	1050	14.5×23	2.00	1000			
82	16×19	1.40	1000							18×20	2.30	800
	12.5×35	1.20	1050	13×25	1.70	1150	13×27	1.70	1100			
	13×23	1.50	1150	14.5×23	1.70	1100	14.5×25	1.80	1050			
	14.5×20	1.50	1200				16×25	1.37	1178			
100	18×19	1.08	1180							18×25	1.97	968
	10×50	1.40	1220	13×27	1.50	1200	12.5×45	1.64	1180			
	13×25	1.40	1280	14.5×25	1.50	1160	14.5×27	1.60	1120			
	14.5×23	1.40	1280				18×25	1.08	1226			
120	18×20	1.08	1180									
	13×27	1.30	1330				12.5×50	1.50	1298			
	14.5×25	1.30	1330	14.5×27	1.30	1220						
150	18×24	0.90	1318									
	14.5×27	1.20	1450									
180	16×35.5	0.80	1180				18×35.5	1.40	1618			
220							16×45	1.37	2200			
270	18×40	0.80	1880				18×45	0.85	2300			
	16×50	0.70	2320									

KCG NEW

- ◆ Ultra-compact size, high voltage, large capacity, dedicated product for direct charging and fast charging power supplies
- ◆ 105°C 4000H/115°C 2000H
- ◆ Lightning resistant, low leakage current (low standby power consumption), high ripple current, high frequency and low impedance
- ◆ RoHS compliant product



■ Main technical parameters

project	characteristic				
Operating Temperature Range	- 40~+105°C				
Nominal Voltage Range	400V				
Capacity Tolerance	±20% (25±2°C 120Hz)				
Leakage Current (μA)	400WV I ≤ 0.015CV + 10(μA) C: Nominal Capacity (μF) V: Rated Voltage (V) Reading after 2 minutes				
Loss Tangent (25 ± 2° C 120Hz)	<table border="1" style="width: 100%;"> <tr> <td>Rated voltage (V)</td> <td>400</td> </tr> <tr> <td>tg δ</td> <td>0.15</td> </tr> </table>	Rated voltage (V)	400	tg δ	0.15
	Rated voltage (V)	400			
tg δ	0.15				
For nominal capacities exceeding 1000 μF, the loss tangent increases by 0.02 for every additional 1000 μF.					
Temperature Characteristics (120Hz)	<table border="1" style="width: 100%;"> <tr> <td>Rated voltage (V)</td> <td>400</td> </tr> <tr> <td>Impedance ratio Z(-40°C)/Z(20°C)</td> <td>7</td> </tr> </table>	Rated voltage (V)	400	Impedance ratio Z(-40°C)/Z(20°C)	7
	Rated voltage (V)	400			
Impedance ratio Z(-40°C)/Z(20°C)	7				
After being stored at 105°C for 1000 hours and then placed at room temperature for 16 hours for testing at a test temperature of 25±2°C, the capacitor performance should meet the following requirements.					
Durability	Capacity change rate	Within ±20% of the initial value			
	Loss tangent	Below 200% of the specified value			
	Leakage current	Below the specified value			
	Load life	<table border="1" style="width: 100%;"> <tr> <td>≥Φ8</td> <td>115°C 2000h</td> <td>105°C 4000h</td> </tr> </table>	≥Φ8	115°C 2000h	105°C 4000h
≥Φ8	115°C 2000h	105°C 4000h			
High Temperature Storage	After being stored at 105°C for 1000 hours and then placed at room temperature for 16 hours for testing at a test temperature of 25±2°C, the capacitor performance should meet the following requirements.				
	Capacity change rate	Within ±20% of the initial value			
	Loss tangent	Below 200% of the specified value			
	Leakage current	Below 200% of the specified value			

■ Product dimension drawing (unit: mm)

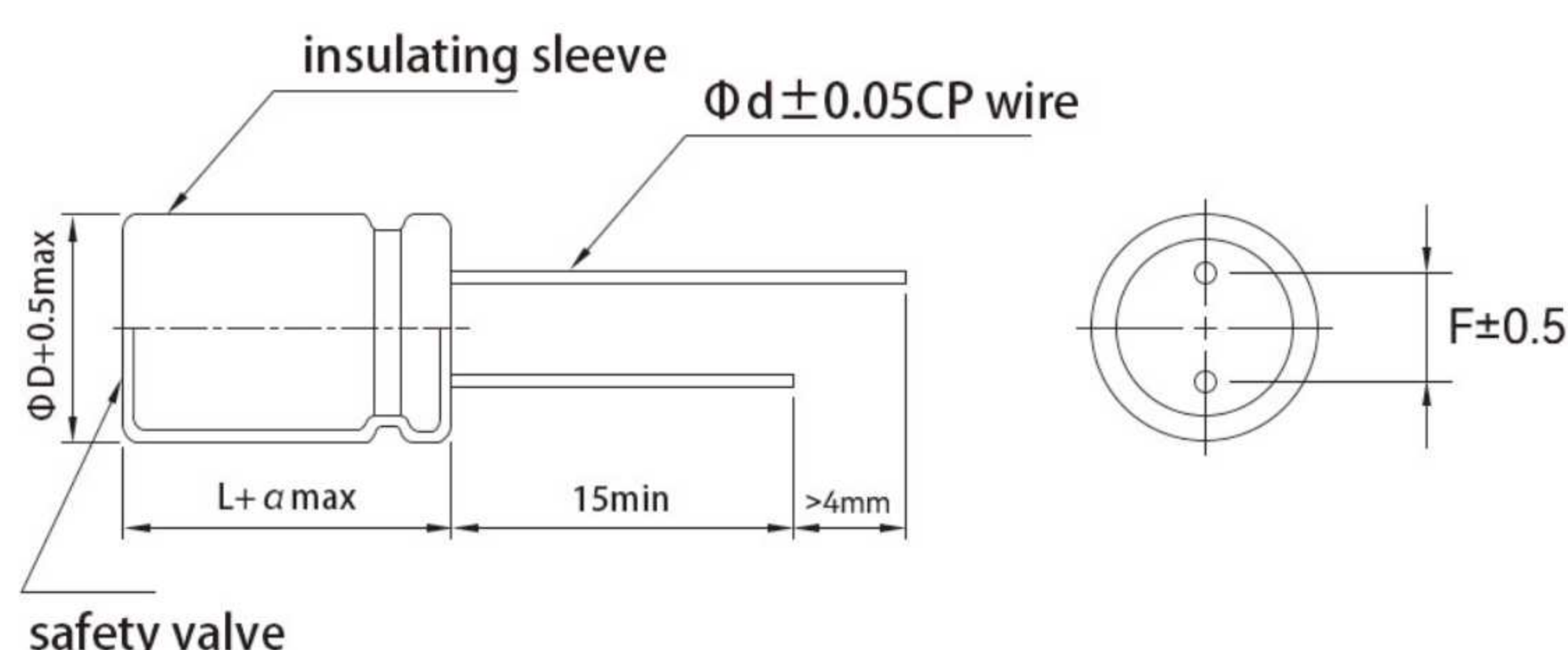

safety valve

Note: Products ≥ Φ6.3 have a safety valve.

D	5	6.3	7	8	10	12.5~13	12.5~13(高度≥30)	14.5	16	18
d	0.5	0.5	0.6	0.6	0.6	0.7	0.6	0.8	0.8	0.8
F	2.0	2.5	3.5	3.5	5.0	5.0	5.0	7.5	7.5	7.5
α	+1									

■ Frequency correction factor

Frequency (Hz)	50	120	1K	10K~50K	100K
coefficient	0.40	0.50	0.80	0.90	1.00

KCG

■ List of Standard Products

Voltage (V)	400		
project	Dimensions: ΦD×L (mm)	Impedance (Ω _{max} /100kHz 25±2°C)	Ripple current (mA r.m.s / 105°C 120Hz)
Capacity (μF)			
10	8×11	5.40	205
12	8×13	4.20	248
15	8×14	3.20	281
18	8×17	3.20	319
22	8×20	3.10	340
	10×14	3.10	340
27	8×25	3.00	372
	10×17	3.00	396
33	10×19	2.50	475
	12.5×16	2.50	475
39	10×23	2.18	562
	12.5×18	2.18	562
47	12.5×20	1.98	665
56	12.5×25	1.40	797
	16×20	1.68	797
68	12.5×30	1.40	1000
82	16×25	1.08	1242
	12.5×35	1.20	1050
100	18×25	0.90	1423
120	18×30	0.90	1648

NPX

- ◆ High reliability, low ESR, high permissible ripple current
- ◆ 105°C, 2000-hour warranty
- ◆ RoHS compliant
- ◆ Miniaturized



List of Standard Products

project	characteristic	
Operating temperature range	- 55 ~ +105°C	
Rated operating voltage	6.3 ~ 100V	
Capacity range	2.2 ~ 10000μF 120Hz 20°C	
Capacity tolerance	±20% (120Hz 20°C)	
Loss tangent	Values below the standard product list: 120Hz, 20°C	
Leakage current	Values below the standard product list: Charged for 2 minutes at rated voltage, 20°C	
Equivalent series resistance (ESR)	Values below the standard product list: 100kHz, 20°C	
Durability	After being subjected to the rated operating voltage for 2000 hours at 105°C and placed at 20°C for 16 hours, the product should meet the following requirements.	
	Rate of change of capacitance	±20% of the initial value
	Equivalent series resistance (ESR)	≦ 150% of the initial specification value
	Loss tangent	≦ 150% of the initial specification value
High temperature and humidity	After being placed at 60°C and 90%~95% RH without voltage for 1000 hours, and then placed at 20°C for 16 hours, the product should meet the following requirements.	
	Rate of change of capacitance	±20% of the initial value
	Equivalent series resistance (ESR)	≦ 150% of the initial specification value
	Leakage current	≦ Initial specification value

※If there is any doubt about the leakage current value, please place the product at 105° C and apply the rated operating voltage for 2 hours, then cool it down to 20° C before testing the leakage current.

Product dimension drawing (unit: mm)

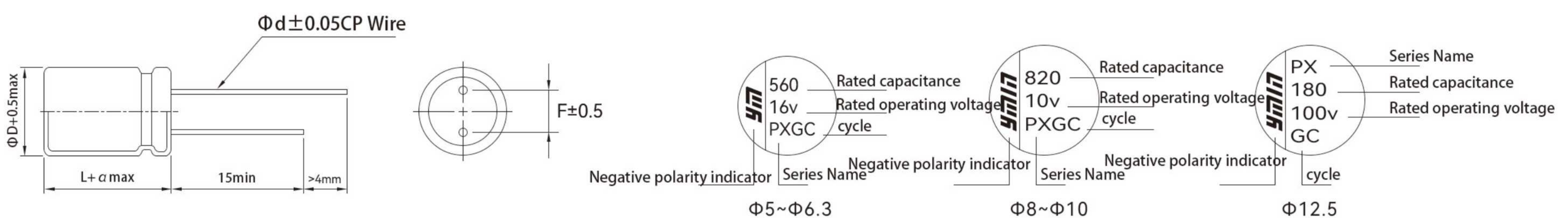

D (±0.5)	5	5.5	6.3	8	10	12.5
d (±0.05)	0.45/0.50	0.45/0.50	0.45/0.50	0.6	0.6	0.6
F (±0.5)	2	2.5	2.5	3.5	5	5
α	+1					

Frequency correction factor

Frequency (Hz)	120Hz	1kHz	10kHz	100kHz	500kHz
Correction Factor	0.05	0.30	0.70	1.00	1.00



NPX

■ List of Standard Products

Rated voltage (V)	nominal capacity (μF)	size ΦD×L(mm)	L.C. (μA,2min)	Tan δ 120Hz	ESR (mΩ100kHz)	Rated ripple current (mA r.m.s/105°C100kHz)
6.3(7.2)	100	5×5.7	300	0.08	20	2400
6.3(7.2)	100	6.3×4.2	300	0.08	40	2500
6.3(7.2)	100	6.3×7	300	0.08	8	4800
6.3(7.2)	150	5×5.7	300	0.08	20	2400
6.3(7.2)	150	6.3×4.2	300	0.08	40	2500
6.3(7.2)	180	5×5.7	300	0.08	20	2400
6.3(7.2)	180	6.3×4.2	300	0.08	40	2500
6.3(7.2)	220	5×5.7	300	0.08	20	2400
6.3(7.2)	220	5×7	300	0.08	12	3400
6.3(7.2)	220	6.3×4.2	300	0.08	40	2500
6.3(7.2)	270	5×7	340	0.08	12	3400
6.3(7.2)	270	6.3×5.7	340	0.08	18	2800
6.3(7.2)	330	5×7	416	0.08	12	3400
6.3(7.2)	330	6.3×5.7	416	0.08	18	2800
6.3(7.2)	390	5×7	491	0.08	12	3400
6.3(7.2)	390	6.3×5.7	491	0.08	18	2800
6.3(7.2)	470	5×8	592	0.08	12	3650
6.3(7.2)	470	6.3×7	592	0.08	8	4800
6.3(7.2)	560	6.3×7	706	0.08	8	4800
6.3(7.2)	560	6.3×9	706	0.08	8	5250
6.3(7.2)	560	8×7	706	0.08	12	4200
6.3(7.2)	680	5×9	857	0.08	10	3850
6.3(7.2)	680	6.3×8	857	0.08	8	5000
6.3(7.2)	680	8×7	857	0.08	12	4200
6.3(7.2)	820	6.3×7.5	1033	0.08	8	4900
6.3(7.2)	820	6.3×9	1033	0.08	8	5250
6.3(7.2)	820	8×7	1033	0.08	12	4200
6.3(7.2)	1000	6.3×10	1260	0.08	8	5500
6.3(7.2)	1000	8×8	1260	0.08	8	5600
6.3(7.2)	1000	8×11	1260	0.08	8	6150
6.3(7.2)	1000	10×7	1260	0.08	12	4500
6.3(7.2)	1200	6.3×11	1512	0.09	8	5700
6.3(7.2)	1200	8×9	1512	0.09	8	5800
6.3(7.2)	1200	10×8	1512	0.09	8	5800
6.3(7.2)	1500	8×11	1890	0.09	8	6150
6.3(7.2)	1500	8×16	1890	0.09	7	7750
6.3(7.2)	1500	10×9	1890	0.09	8	6050
6.3(7.2)	1500	10×10	1890	0.09	8	6300
6.3(7.2)	2000	8×14	2520	0.10	7	7250
6.3(7.2)	2000	10×10	2520	0.10	8	6300
6.3(7.2)	2200	8×14	2772	0.10	7	7250
6.3(7.2)	2200	10×10	2772	0.10	8	6300
6.3(7.2)	2500	10×12	3150	0.10	8	6500

NPX

■ List of Standard Products

Rated voltage (V)	nominal capacity (μF)	size ΦD×L(mm)	L.C. (μA,2min)	Tan δ 120Hz	ESR (mΩ100kHz)	Rated ripple current (mA r.m.s/105°C100kHz)
6.3(7.2)	2700	10×12	3402	0.10	8	6500
6.3(7.2)	3300	10×12	4158	0.11	8	6500
6.3(7.2)	3300	10×16	4158	0.11	8	8100
6.3(7.2)	3900	10×14	4914	0.11	7	7600
6.3(7.2)	4700	10×16	5922	0.12	8	8100
6.3(7.2)	4700	12.5×12.5	5922	0.12	8	7600
6.3(7.2)	5600	10×18	7056	0.13	7	8500
6.3(7.2)	5600	12.5×14	7056	0.13	8	7900
6.3(7.2)	6800	10×21	7500	0.14	7	9100
6.3(7.2)	6800	12.5×16	7500	0.14	7	8950
6.3(7.2)	8200	12.5×18	7500	0.16	7	9450
6.3(7.2)	10000	12.5×20	7500	0.18	7	9850
7.5(8.6)	270	5×7	405	0.08	12	3400
7.5(8.6)	270	6.3×5.7	405	0.08	18	2800
7.5(8.6)	330	5×9	495	0.08	12	3800
7.5(8.6)	330	6.3×5.7	495	0.08	18	2800
7.5(8.6)	390	5×10	585	0.08	10	4350
7.5(8.6)	390	6.3×7	585	0.08	12	3900
7.5(8.6)	470	5×9	705	0.08	12	3800
7.5(8.6)	470	5×11	705	0.08	10	4500
7.5(8.6)	470	6.3×8	705	0.08	12	4100
7.5(8.6)	560	6.3×9	840	0.08	9	5000
7.5(8.6)	680	6.3×10	1020	0.08	8	5500
7.5(8.6)	680	8×7	1020	0.08	12	4200
7.5(8.6)	820	6.3×11	1230	0.08	8	5700
7.5(8.6)	820	8×8	1230	0.08	8	5600
7.5(8.6)	1000	6.3×11	1500	0.08	8	5700
7.5(8.6)	1000	8×9	1500	0.08	8	5800
7.5(8.6)	1500	6.3×15	2250	0.09	8	6650
10(11.5)	47	5×5.7	300	0.08	30	1900
10(11.5)	47	6.3×4.2	300	0.08	40	2100
10(11.5)	68	5×5.7	300	0.08	30	1900
10(11.5)	68	6.3×4.2	300	0.08	40	2100
10(11.5)	82	5×5.7	300	0.08	30	1900
10(11.5)	82	6.3×4.2	300	0.08	40	2100
10(11.5)	100	5×5	300	0.08	30	1900
10(11.5)	100	5×5.7	300	0.08	30	1900
10(11.5)	100	6.3×4.2	300	0.08	40	2100
10(11.5)	150	5×7	300	0.08	15	3050
10(11.5)	150	6.3×5.7	300	0.08	30	2200
10(11.5)	180	5×7	360	0.08	15	3050
10(11.5)	180	6.3×5.7	360	0.08	30	2200
10(11.5)	220	5×7	440	0.08	15	3050

VPX

- ◆ High reliability, low ESR, high permissible ripple current
- ◆ 105°C, 2000-hour warranty
- ◆ RoHS compliant
- ◆ Miniaturized, surface mountable



■ Main technical parameters

project	characteristic	
Operating temperature range	- 55 ~ +105°C	
Rated operating voltage	6.3 ~ 100V	
Capacity range	2.2 ~ 10000 μ F 120Hz 20°C	
Capacity tolerance	\pm 20% (120Hz 20°C)	
Loss tangent	Values below the standard product list: 120Hz, 20°C	
Leakage current	Values below the standard product list: Charged for 2 minutes at rated voltage, 20°C	
Equivalent series resistance (ESR)	Values below the standard product list: 100kHz, 20°C	
Durability	After being subjected to the rated operating voltage for 2000 hours at 105°C and placed at 20°C for 16 hours, the product should meet the following requirements.	
	Rate of change of capacitance	\pm 20% of the initial value
	Equivalent series resistance (ESR)	\leq 150% of the initial specification value
	Loss tangent	\leq 150% of the initial specification value
	Leakage current	\leq Initial specification value
High temperature and humidity	After being placed at 60°C and 90%~95% RH without voltage for 1000 hours, and then placed at 20°C for 16 hours, the product should meet the following requirements.	
	Rate of change of capacitance	\pm 20% of the initial value
	Equivalent series resistance (ESR)	\leq 150% of the initial specification value
	Loss tangent	\leq 150% of the initial specification value
	Leakage current	\leq Initial specification value

※If there is any doubt about the leakage current value, please place the product at 105° C and apply the rated operating voltage for 2 hours, then cool it down to 20° C before testing the leakage current.

■ Product dimension drawing (unit: mm)

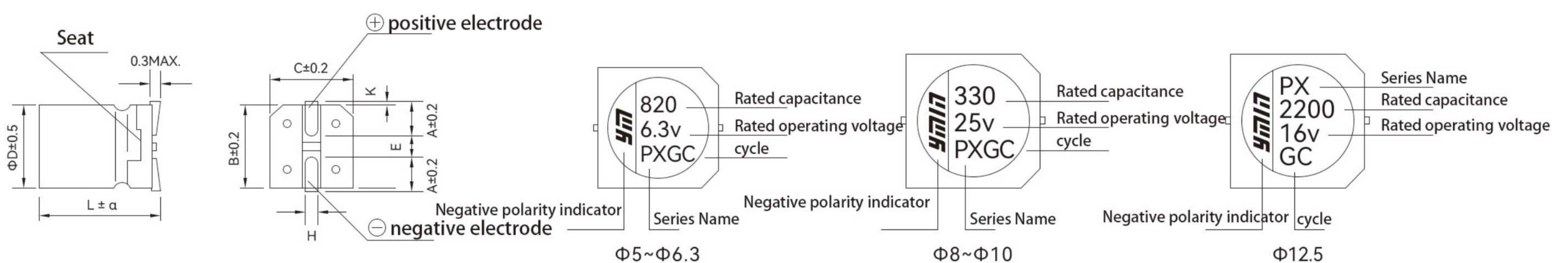

ΦD	B	C	A	H	E	K	α
5	5.3	5.3	2.1	0.70 \pm 0.20	1.3	0.5MAX	± 0.5
6.3	6.6	6.6	2.6	0.70 \pm 0.20	1.8	0.5MAX	
8	8.3	8.3	3.0	0.90 \pm 0.20	3.1	0.5MAX	
10	10.3	10.3	3.5	0.90 \pm 0.20	4.6	0.7 \pm 0.2	± 1.0
12.5	12.8	12.8	4.7	0.90 \pm 0.30	4.4	0.7 \pm 0.3	

■ Rated ripple current frequency correction factor

Frequency (Hz)	120Hz	1kHz	10kHz	100kHz	500kHz
Correction Factor	0.05	0.30	0.70	1.00	1.00

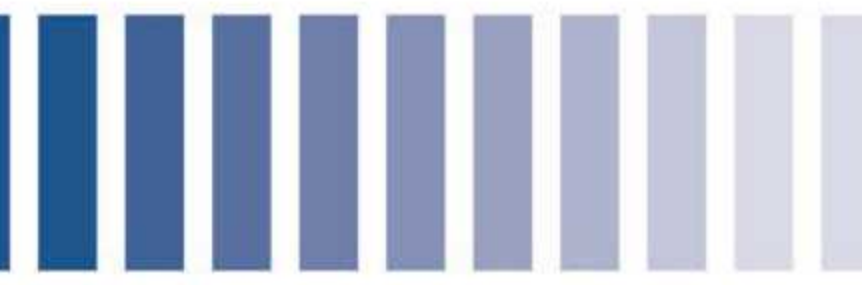

NPM

- ◆ 3.95mm height ultra-thin solid capacitor
- ◆ Low ESR, high reliability
- ◆ 105°C 2000-hour warranty
- ◆ Surface mount type, suitable for high-temperature lead-free reflow soldering
- ◆ RoHS compliant



■ Main technical parameters

project	characteristic	
Operating temperature range	- 55 ~ +105°C	
Rated operating voltage	6.3 ~ 100V	
Capacity range	1.2 ~ 270 μF 120Hz 20°C	
Capacity tolerance	±20% (120Hz 20°C)	
Loss tangent	The following values are from the standard product list: 120Hz, 20°C	
Leakage current	Charge for 2 minutes at rated voltage using 0.2CV or 1000 μA, at 20°C.	
Equivalent series resistance (ESR)	The following values are from the standard product list: 100kHz, 20°C.	
Durability	After being subjected to the rated operating voltage for 2000 hours at 105°C and placed at 20°C for 16 hours, the product should meet the following requirements.	
	Rate of change of capacitance	± 20% of the initial value
	Equivalent series resistance (ESR)	≦ 150% of the initial specification value
	Loss tangent	≦ 150% of the initial specification value
	Leakage current	≦ Initial specification value
High temperature and humidity	After being placed at 60°C and 90%~95% RH without voltage for 1000 hours, and then placed at 20°C for 16 hours, the product should meet the following requirements.	
	Rate of change of capacitance	± 20% of the initial value
	Equivalent series resistance (ESR)	≦ 150% of the initial specification value
	Loss tangent	≦ 150% of the initial specification value
	Leakage current	≦ Initial specification value

※ If there is any doubt about the leakage current value, please place the product at 105° C and apply the rated operating voltage for 2 hours, then cool it down to 20° C before testing the leakage current.

■ Product dimension drawing (unit: mm)

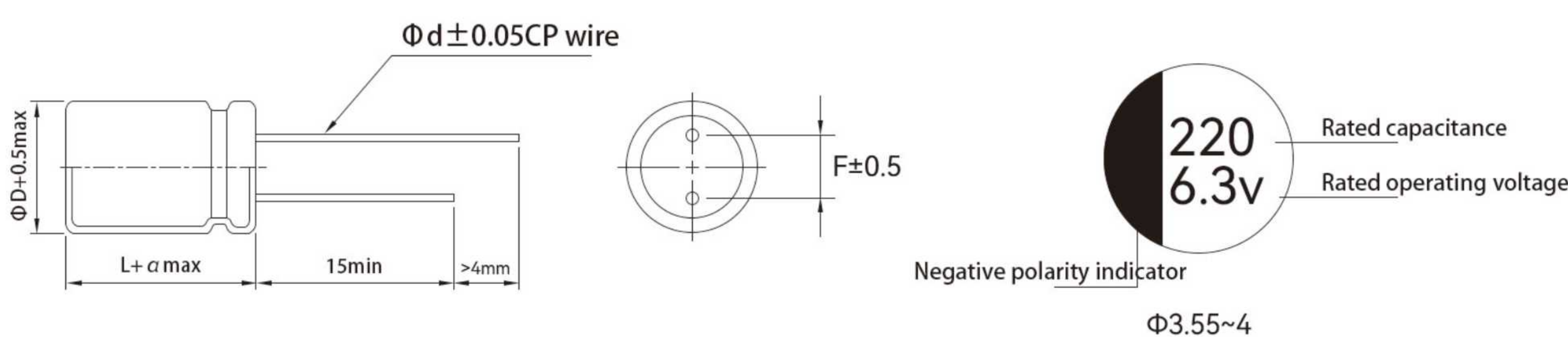

D (±0.5)	3.55×11	4×7	4×9	4×11
d (±0.05)	0.40	0.50	0.50	0.50
F (±0.5)	1.5			
α	+1.0			

■ Frequency correction factor

Frequency (Hz)	120Hz	1kHz	10kHz	100kHz	500kHz
Correction Factor	0.05	0.30	0.70	1.00	1.00

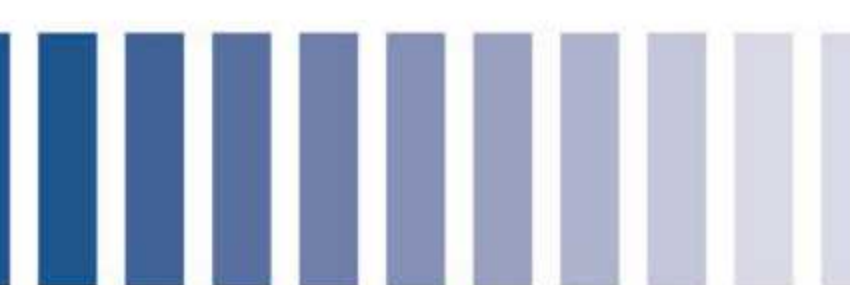

VP4

- ◆ 3.95mm height ultra-thin solid capacitor
- ◆ Low ESR, high reliability
- ◆ 105°C 2000-hour warranty
- ◆ Surface mount type, suitable for high-temperature lead-free reflow soldering
- ◆ RoHS compliant



■ Main technical parameters

project	characteristic	
Operating temperature range	- 55 ~ +105°C	
Rated operating voltage	6.3 ~ 35V	
Capacity range	33~ 220 μ F 120Hz 20°C	
Capacity tolerance	\pm 20% (120Hz 20°C)	
Loss tangent	The following values are from the standard product list: 120Hz, 20°C	
Leakage current	Charge for 2 minutes at rated voltage using 0.2CV or 1000 μ A, at 20°C.	
Equivalent series resistance (ESR)	The following values are from the standard product list: 100kHz, 20°C.	
Durability	After being subjected to the rated operating voltage for 2000 hours at 105°C and placed at 20°C for 16 hours, the product should meet the following requirements.	
	Rate of change of capacitance	\pm 20% of the initial value
	Equivalent series resistance (ESR)	\leq 200% of the initial specification value
	Leakage current	\leq Initial specification value
High temperature and humidity	After being placed at 60°C and 90%~95% RH without voltage for 1000 hours, and then placed at 20°C for 16 hours, the product should meet the following requirements.	
	Rate of change of capacitance	\pm 20% of the initial value
	Equivalent series resistance (ESR)	\leq 200% of the initial specification value
	Leakage current	\leq Initial specification value

※If there is any doubt about the leakage current value, please place the product at 105°C and apply the rated operating voltage for 2 hours, then cool it down to 20°C before testing the leakage current.

■ Product dimension drawing (unit: mm)

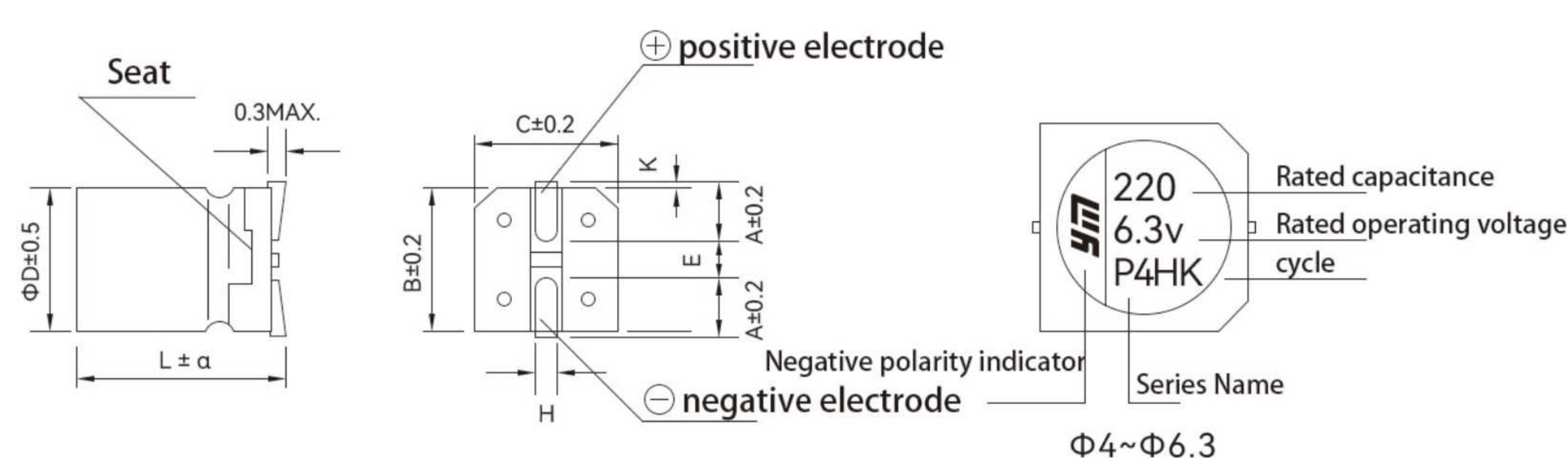

Φ D	B	C	A	H	E	K	α
6.3×3.95	6.6	6.6	2.6	0.90±0.20	1.8	0.5MAX	±0.2

■ Frequency correction factor

Frequency (Hz)	120Hz	1kHz	10kHz	100kHz	500kHz
Correction Factor	0.05	0.30	0.70	1.00	1.00

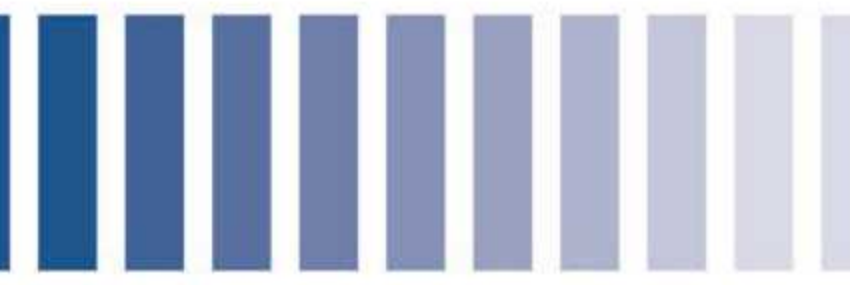

MPD28

- ◆ Low ESR, high ripple current
- ◆ 105°C, 2000-hour warranty
- ◆ High voltage withstand (80V max.), high capacity (820 μF max.)
- ◆ RoHS compliant (2011/65/EU)



■ Main technical parameters

project	characteristic	
Operating temperature range	- 55 ~ +105°C	
Rated operating voltage	2 ~ 80V	
Capacity range	4.7 ~ 820 μF 120Hz 20°C	
Capacity tolerance	±20% (120Hz 20°C)	
Loss tangent	Values below the standard product list: 120Hz, 20°C	
Leakage current	$I \leq 0.1CV$, charged for 2 minutes at rated voltage, 20°C	
Equivalent series resistance (ESR)	Values below the standard product list: 100kHz, 20°C	
Surge voltage (V)	1.15 times the rated voltage	
Durability	After being subjected to the rated operating voltage for 2000 hours at 105°C and placed at 20°C for 16 hours, the product should meet the following requirements.	
	Rate of change of capacitance	±20% of the initial value
	Loss tangent	≦ 200% of the initial specification value
	Leakage current	≦ Initial specification value
High temperature and humidity	After being placed at 60°C and 90%~95% RH for 500 hours without applying voltage, and then placed at 20°C for 16 hours, the product should meet the following requirements.	
	Rate of change of capacitance	±20% of the initial value
	Loss tangent	≦ 200% of the initial specification value
	Leakage current	≦ Initial specification value

■ logo

Capacitance (μF) Positive electrode label

120
25 M18D

Rated voltage (V) Manufacturing code

Manufacturing Coding Rules:
The first digit represents the manufacturing month.

Month	1	2	3	4	5	6	7	8	9	10	11	12
Code	A	B	C	D	E	F	G	H	J	K	L	M

The middle two digits represent the year of manufacture, followed by the last two digits. The last digit is the shell number.

■ External dimensions

unit: mm

L±0.2	W±0.2	H±0.1	W1±0.1	P±0.2
7.3	4.3	2.8	2.4	1.3

■ Temperature coefficient of rated ripple current

temperature	T ≤ 45°C	45°C < T ≤ 85°C	85°C < T ≤ 105°C
2~10V	1.0	0.7	0.25
16~80V	1.0	0.8	0.5

Note: The capacitor surface temperature should not exceed the product's maximum operating temperature.

■ Rated ripple current frequency correction factor

Frequency (Hz)	120Hz	1kHz	10kHz	100~300kHz
Correction Factor	0.10	0.45	0.50	1.00

Main partner brands

安克	BULL 公牛	贝尔金	BASEUS 倍思	飞利浦
华为荣耀	SAMSUNG 三星	NUBIA 努比亚	Mophie	SHARGE闪极
UGREEN 绿联	SlimQ	UIBI (柚比)	易冲	龙冰
京东京造	RAVPower	HYPER JUICE	BIAZE 毕亚兹	机乐堂
斯泰克	TORRAS 图拉斯	爱否开物	HUWDER 鸿达顺	第一卫
网易智造	飞频快充	Lapo	MOMAX 摩米士	邦克仕
Aohi				

Complete product disassembly case

● Anker Nano 20W PD Fast Charger (US Standard)

Yongming Liquid Aluminum Electrolytic Capacitors: KCX 400V 22 μ F 8*18, KCX 400V 10 μ F 8*10
Yongming Solid Aluminum Electrolytic Capacitors: VPX 16V 220 μ F 6.3*5.8



● ANKER 30W GaN Super Charger

Yongming Liquid Aluminum Electrolytic Capacitor: KCX 400V 22 μ F 8*18
Yongming Solid Aluminum Electrolytic Capacitor: NPX 25V 470 μ F 5.5*15
NPX 25V 330 μ F 5*15



● ANKER 45W GaN Supercharger (US Standard)

Yongming Liquid Aluminum Electrolytic Capacitors: KCX 400V 33 μ F 8*24, KCX 400V 27 μ F 8*20
Yongming Solid Aluminum Electrolytic Capacitors: NPX 25V 330 μ F 5*15



● ANKER 65W GaN Super Charger

Yongming Liquid Aluminum Electrolytic Capacitors: KCX 400V 33 μ F 8*24, KCX 400V 22 μ F 8*18
Yongming Solid Aluminum Electrolytic Capacitors: NPX 25V 560 μ F 6.3*14

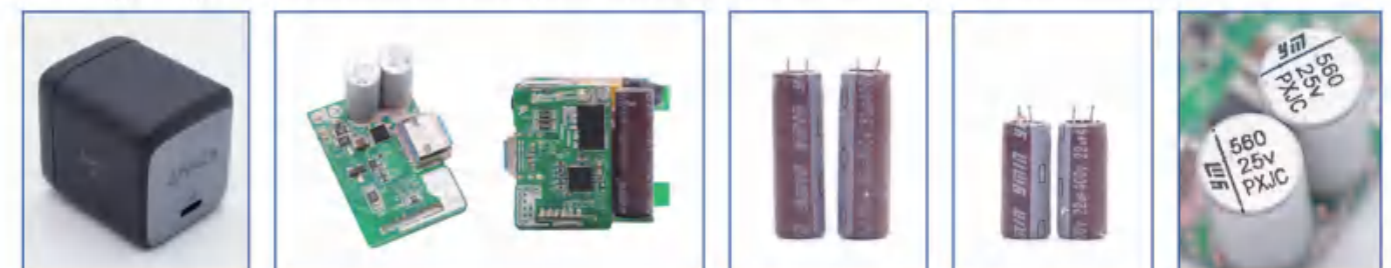

● **Anker 100W 2C1A GaN Super Charger**

YMIN Solid Aluminum Electrolytic Capacitors: NPT 25V 470 μ F 5 \times 15, NPT 25V 220 μ F 6.3 \times 8, NPT 25V 680 μ F 6.3 \times 15



● **Anker GaN 120W Charger**

YMIN Liquid Aluminum Electrolytic Capacitors: KCX 420V 100 μ F 16 \times 25 LK 35V 47 μ F 5 \times 11
YMIN Solid Aluminum Electrolytic Capacitors: NPT 25V 470 μ F 5 \times 15 NPX 25V 1000 μ F 6.3 \times 18
NPX 25V 470 μ F 5 \times 18



● **Anker 140W USB PD3.1 GaN Charger**

Ymin Liquid Aluminum Electrolytic Capacitors: KCX 420V 120 μ F 18 \times 25, L3M 100V 18 μ F 5 \times 11
LK 35V 47 μ F 5 \times 11
Ymin Solid Aluminum Electrolytic Capacitors: NPX 35V 680 μ F 8 \times 16, NPX 35V 560 μ F 6.3 \times 18

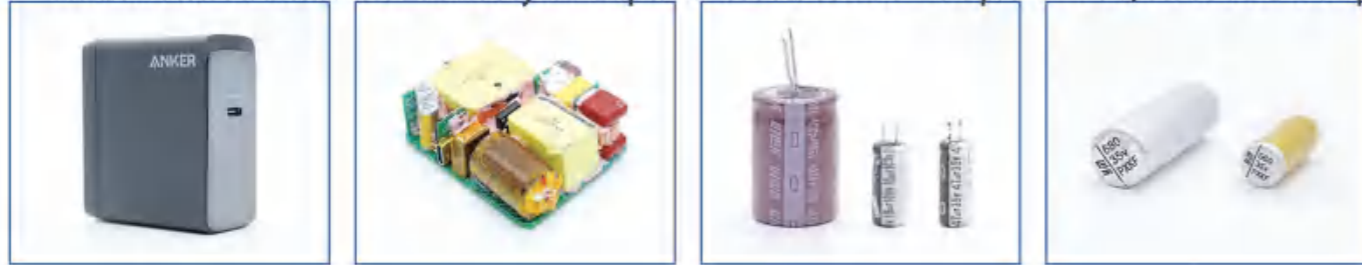

● **Anker 150W 3C1A GaN Charger**

YMIN Liquid Aluminum Electrolytic Capacitors: KCX 420V 120 μ F 18 \times 25, LK 35V 47 μ F 5 \times 11
YMIN Solid Aluminum Electrolytic Capacitors: VPT 25V 220 μ F 5.5 \times 9, NPT 25V 470 μ F 5 \times 10

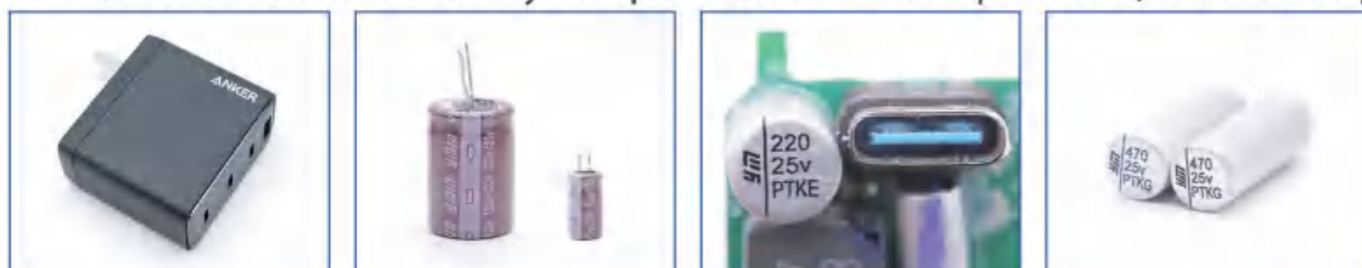

● **Aohi 30000mAh 100W Two-Way Fast Charging Power Bank**

YMIN Solid Aluminum Electrolytic Capacitor: NPH 35V 100 μ F 6.3 \times 7



● **Baseus 15W Minimalist Magnetic Wireless Charger (Compatible with iPhone 12)**

YMIN Solid Aluminum Electrolytic Capacitors: NPM 25V 100 μ F 3.55 \times 11

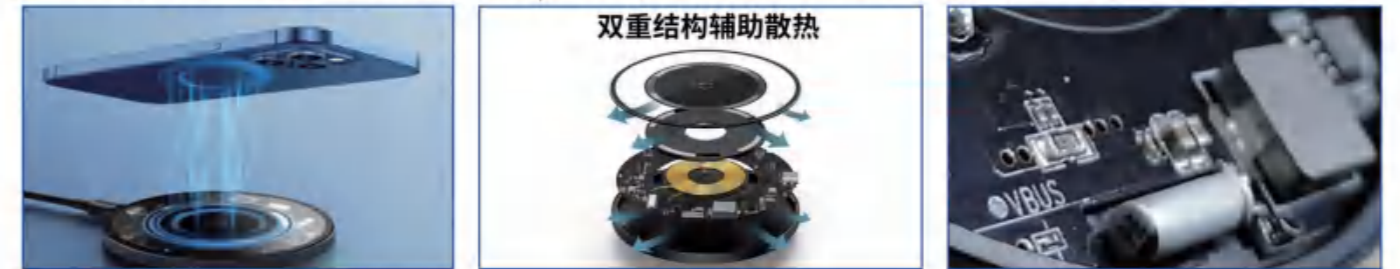

● **BASEUS 45W 1A1C GaN Charger CCGAN45UC**

YMIN liquid aluminum electrolytic capacitor: KCX 400V 22 μ F 8 \times 20
YMIN solid aluminum electrolytic capacitor: NPX 25V 220 μ F 6.3 \times 8



● **Baseus 160W 2C1A GaN Charger**

YMIN Solid Aluminum Electrolytic Capacitor: NPT 25V 220 μ F 5.5 \times 9



● Philips 65W Fast Charging Socket Teardown

YMIN Liquid Aluminum Electrolytic Capacitor: KCX 400V 56 μ F 13*20
 YMIN Liquid Aluminum Electrolytic Capacitor: LMM 25V 680 μ F

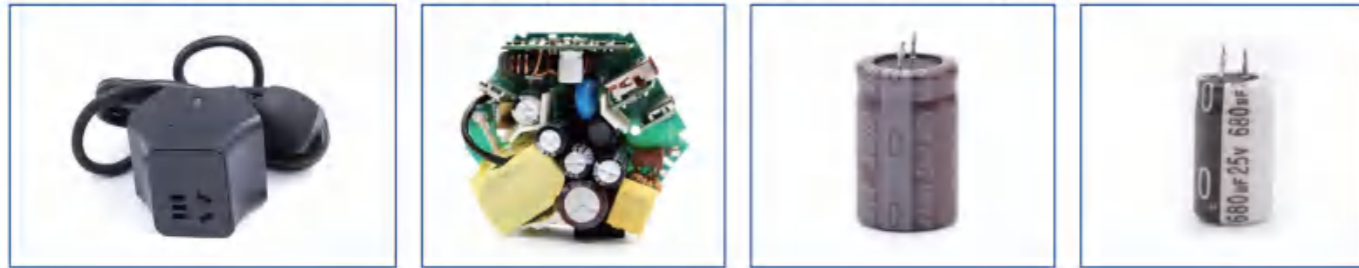

● BULL 2A1C 65W Fast Charging Six-Outlet Extension Cord Socket GNV-UU2656

YMIN Liquid Aluminum Electrolytic Capacitor: KCX 400V 27 μ F 8*20

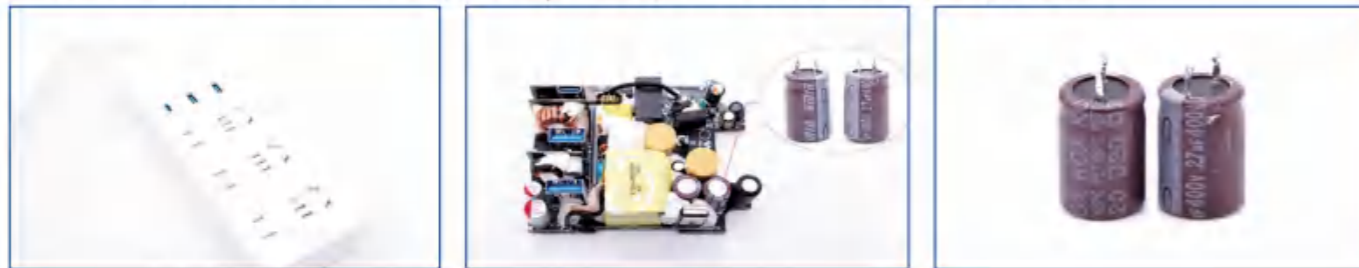

● NUBIA 65W 2C1A GaN Fast Charger FC83C

YMIN Liquid Aluminum Electrolytic Capacitors: KCX 400V 33 μ F 10*18, KCX 400V 22 μ F 8*18
 YMIN Solid Aluminum Electrolytic Capacitors: NPX 25V 330 μ F 5.5*12, NPX 25V 220 μ F 5.5*9



● Nubia 120W 2C1A Three-Port GaN Fast Charger

YMIN Liquid Aluminum Electrolytic Capacitor: KCX 400V 22 μ F 8*16



● UGREEN 65W USB PD GaN Fast Charger CD217

YMIN Liquid Aluminum Electrolytic Capacitor: KCX 400V 22 μ F 8*18

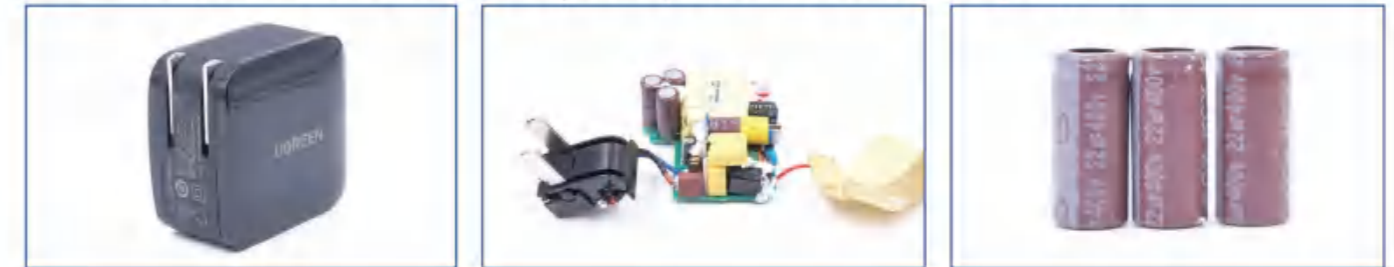

● HUWDER Hongda Shun 65W 2C1A GaN Fast Charger A1901-2

YMIN Liquid Aluminum Electrolytic Capacitor: KCX 400V 33 μ F 10*18
 YMIN Solid Aluminum Electrolytic Capacitor: NPX 25V 560 μ F 6.3*14

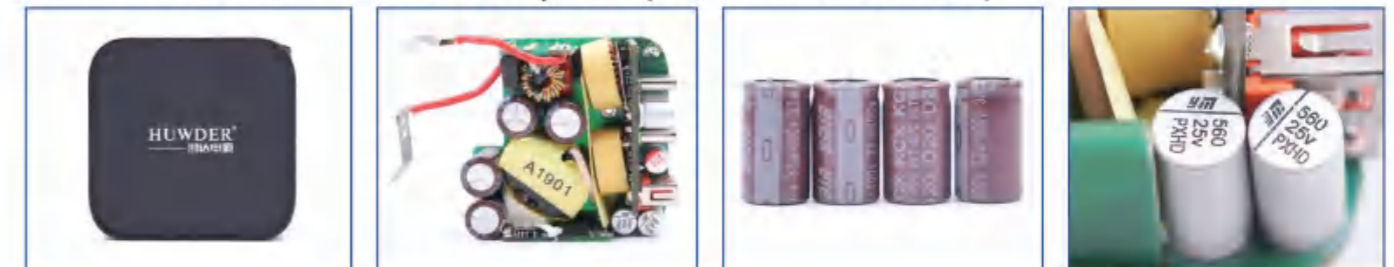

● RAVPOWER 90W Dual USB-C Port PD Fast Charger RP-CPCN001

YMIN Solid Aluminum Electrolytic Capacitors: NPX 25V 1000 μ F 8*16



● BIAZE 2C1A 65W GaN Charger FC83C

YMIN Liquid Aluminum Electrolytic Capacitors: KCX 400V 33 μ F 10*18, KCX 400V 22 μ F 8*18
 YMIN Solid Aluminum Electrolytic Capacitors: NPX 25V 330 μ F 5.5*12



- **SLIMQ 65W GaN USB PD Fast Charger SLIMQ-GaN65AC**
 YMIN Liquid Aluminum Electrolytic Capacitor: KCX 400V 33 μ F 10*18
 YMIN Solid Aluminum Electrolytic Capacitor: NPX 25V 820 μ F 8*14

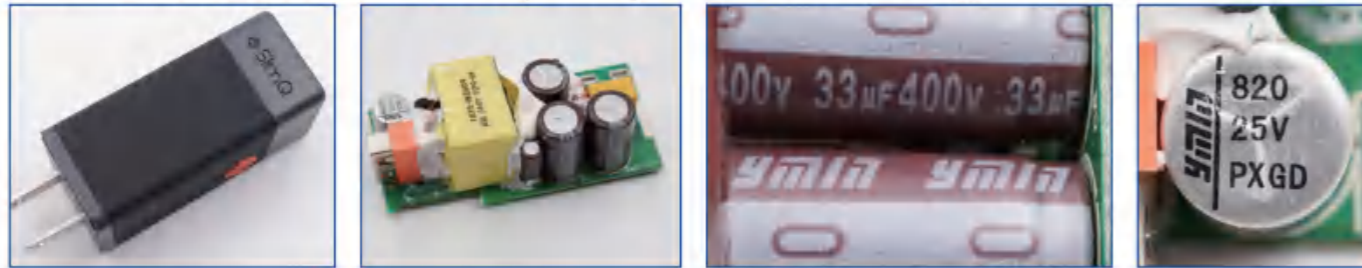

- **NetEase Smart Manufacturing 1A1C 65W GaN Fast Charger**
 YMIN Liquid Aluminum Electrolytic Capacitor: KCX 400V 33 μ F 10*18



- **SlimQ 150W DC+2C Fast Charging GaN Charger**
 YMIN Liquid Aluminum Electrolytic Capacitor: KCX 400V 33 μ F 10*16
 YMIN Solid Aluminum Electrolytic Capacitor: NPX 25V 1000 μ F 8*16



- **SAMSUNG 10000mAh 25W PD Fast Charging Power Bank EB-3300**
 YMIN Solid Aluminum Electrolytic Capacitor: VPX 20V 120 μ F 6.3*5.8



- **TORRAS 24W 1A1C Fast Charger CDRA23**
 YMIN Solid Aluminum Electrolytic Capacitor: NPX 16V 820 μ F 6.3*15



- **JD.com 65W 1A1C GaN Fast Charger TC-028**
 YMIN Liquid Aluminum Electrolytic Capacitor: KCX 400V 22 μ F 8*18



- **Stek P49-PD-100W Dual USB-C GaN PD Fast Charger**
 YMIN Solid Aluminum Electrolytic Capacitors: NPX 25V 1000 μ F 8*16



- **Flypoint 65W USB PD GaN Charger FC139C**
 YMIN Solid Aluminum Electrolytic Capacitor: NPX 25V 330 μ F 6.3*11



● Infineon 65W GaN PD Fast Charging Solution



YMIN Capacitors	YMIN Capacitors
KCX 400V 33 μ F 10*18	NPX 25V 680 μ F 8*14
KCX 400V 22 μ F 8*18	NPX 25V 470 μ F 6.3*12

● HYPER JUICE 100W GaN Charger

YMIN Liquid Aluminum Electrolytic Capacitor: KCX 400V 27 μ F 10*15



● UIBI 20W Mini Folding Charger

YMIN Liquid Aluminum Electrolytic Capacitor: KCX 400V 18 μ F 8*15

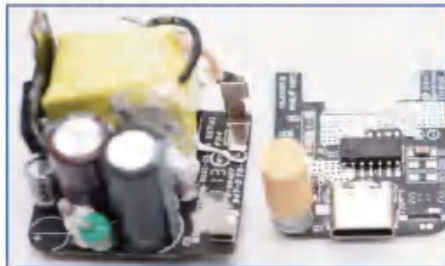

● Huaxingke 22.5W Fast Charger

YMIN Liquid Aluminum Electrolytic Capacitor: KCX 400V 10 μ F 8*10
 YMIN Solid Aluminum Electrolytic Capacitor: NPX 16V 220 μ F 6.3*5.7



● SHARGE 100W 3C1A GaN Fast Charger

YMIN Solid Aluminum Electrolytic Capacitors: NPX 25V 820 μ F 8*14

NPX 25V 470 μ F 6.3*12 NPX 25V 330 μ F 5.5*12

YMIN Liquid Aluminum Electrolytic Capacitors: GP 450V 68 μ F 18*31.5

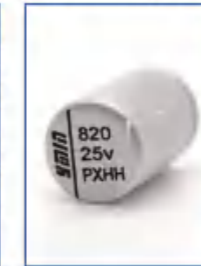

● AHL 10W Wireless Car Charger (Korea)

YMIN's miniature supercapacitor module products: SDM 5.5V 0.47F 13*6.3*12



● Jiletang 30W 1A1C Fast Charger

YMIN Liquid Aluminum Electrolytic Capacitor: KCX 400V 33 μ F 10*18

YMIN Solid Aluminum Electrolytic Capacitor: NPX 25V 560 μ F 6.3*14

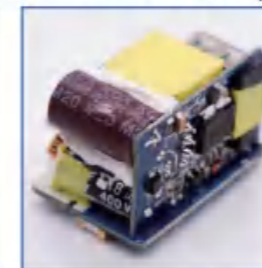

● Mini-tech 20W USB PD Fast Charger

YMIN Solid Aluminum Electrolytic Capacitor: NPX 12V 820 μ F

