

Company Profile (P01~P02)

Motor Drive  
Application  
Introduction  
P03~P13

Smart Mobility 03

robot 05

drones 07

power tools 09

Automotive  
thermal management 11

Smart home  
appliances 13

Capacitor Series  
Introduction  
(P14~P66)

Liquid surface mount aluminum electrolytic capacitors

105℃

V3MC series (2000H) /  
V3M series (2000~5000H) 15

VMM series (3000~8000H) 17  
VKM series (7000~10000H) /

125℃

VKL series (2000~5000H) 22



Liquid leaded aluminum electrolytic capacitor

105℃

LK series (6000~8000H) 26  
LKM series (7000~10000H) 33

LKE series (10000H) 39  
LKZ series (10000~15000H) 43

135℃

LKL(R) series (3000H) 51



Polymer hybrid aluminum electrolytic capacitor

105℃

VHX series (2000~5000H) 54  
NHX series (2000~5000H) 65

125℃

VHT Series (4000H) 57  
VHE Series (4000H) 60

150℃

VHR series (2000H) 63



# Company List

COMPANY LIST



# Qualification Certificate

## QUALIFICATION CERTIFICATE



NATIONAL MILITARY STANDARD  
QUALITY MANAGEMENT SYSTEM  
CERTIFICATION



IATF 16949 SYSTEM  
CERTIFICATION



CNAS ACCREDITATION IS  
UNDERWAY...



AEC-Q200 PRODUCT  
CERTIFICATION

# Automated production line

## AUTOMATED PRODUCTION LINE

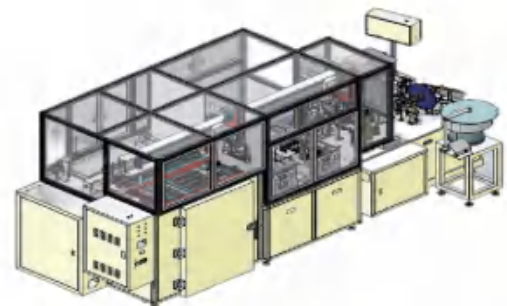

YMIN Electronics' all-capacitor production line is a high-end production line integrating automation, digitalization, and intelligence, ensuring product manufacturing quality and production efficiency.

The entire process is automated, connecting five core processes. Materials flow automatically, process parameters are intelligently matched, and equipment automation exceeds 90%, with human intervention less than 10%. Three-dimensional inspection integrates electrical performance testing, CCD vision, and laser measurement, with data uploaded to the cloud in real time, ensuring 100% effective rejection of defective products. The Industrial Internet of Things (IIoT) collects over 300 quality parameters in real time, and the MES system enables full-process traceability and equipment visualization.

# Smart Mobility

## SMART MOBILITY

IMAGE FOR REFERENCE ONLY.



LOW-SPEED

ELECTRIC VEHICLES



SPECIAL ENGINEERING

VEHICLES



HIGH-SPEED ELECTRIC

MOTORCYCLE



ELECTRIC FORKLIFT SELF-BALANCING



SCOOTER

## Application Requirements

Ultra-low ESR; seismic performance; high ripple resistance and overload capacity;

## Yongming Capacitor Product Advantages

### Ultra-low ESR

The capacitor has an ultra-low ESR, ensuring filtering effect, reducing heat generation, and improving overall energy efficiency;

### Seismic performance

The W-type process ensures that the capacitors are resistant to vehicle bumps and road vibrations and work stably, guaranteeing the stable and effective operation of the controller.

### High ripple resistance, overload capacity

It can withstand ultra-high current surges, with a single unit capable of withstanding up to 30A surges, ensuring normal operation and stable performance of the capacitor under high load and high power conditions.

### Impact resistance

The specially thickened guide pin design enhances the product's shock resistance and high current withstand capability.

## Recommended selection (the following are sample specifications for reference only)

Capacitor type	shape	series	Temperature life	Rated Voltage (Surge Voltage) (V)	Nominal capacity (μF)	Product dimensions Φ*H. (mm)	Tan (120HZ)	ESR (Ω/100kHz)	Rated ripple current (mA/100kHz)	LC (μA)	Product Part Number	page number
Liquid aluminum electrolytic capacitors	surface mount type	V3M	105°C 2000H	10 (11.5)	470	6.3*7.7	0.19	0.320	600	47	V3MC0771A471MVTMCG	15
		V3M	105°C 5000H	50 (62.5)	220	10*10	0.12	0.250	670	110	V3ME1001H221MVTMCG	15
		VKL	125°C 3000H	35 (43.8)	220	10*10	0.16	0.300	670	77	VKLE1001V221MVTMCG	22
		VKL	125°C 4000H	80 (92)	220	12.5*21	0.16	0.240	890	176	VKLL2101K221MVTMCG	22
		VKM	105°C 10000H	100 (125)	100	10*14.5	0.12	0.640	1040	100	VKME1452A221MV	/
	Lead type	LKE	105°C 10000H	63 (79)	470	13*25	0.09	0.048	1800	296	LKES2501J471MF	39
		LKE	105°C 10000H	100 (125)	220	13*25	0.09	0.067	1460	220	LKES2502A221MF	39

Recommended selection (the following are sample specifications for reference only)

Capacitor type	shape	series	Temperature life	Rated Voltage (Surge Voltage) (V)	Nominal capacity ( $\mu$ F)	Product dimensions $\Phi$ D $\times$ L (mm)	Tan (120HZ)	ESR ( $\Omega$ /100kHz)	Rated ripple current (mA/100kHz)	LC ( $\mu$ A)	Product Part Number	page number
Liquid aluminum electrolytic capacitors	Lead type	LKE	105°C 10000H	100 (125)	330	13*25	0.09	0.066	1620	330	LKES2502A331MF	39
		LKE	105°C 10000H	120 (170)	150	13*20	0.09	0.093	1368	180	LKES2002K151MF	39
		LKE	105°C 10000H	160 (210)	220	14.5*25	0.09	3.500	1881	714	LKES2002C221MF	39
		LK	105°C 8000H	100 (125)	560	16*20	0.09	0.030	2100	560	OLKI2002A561MF	26
		LK	105°C 8000H	100 (125)	1200	25*20	0.09	0.022	2900	1200	OLKM2002A122MF	26
		LK	105°C 8000H	100 (125)	1200	16*40	0.09	0.020	3100	1200	OLKI4002A122MF	26
		LK	105°C 8000H	120 (170)	330	12.5*35	0.09	0.040	2200	396	OLKL3502K331MF	26
	M molding	LKE	105°C 10000H	63 (113)	470	13*20	0.09	0.048	1800	296	LKES2501J471MF	39
		LKE	105°C 10000H	100 (125)	470	14.5*25	0.09	0.055	2100	470	LKEU2502A471MF	39
		LKE	105°C 10000H	100 (125)	680	14.5*27	0.09	0.036	2150	680	LKEU2702A681MF	39
Polymer Hybrid Power Aluminum Electrolytic Capacitor	Lead type	NHX	105°C 5000H	100 (115)	200	12.5*16	0.08	0.030	2450	200	NHXL1602A201MJCG	65
		NHX	105°C 5000H	100 (115)	220	12.5*16	0.08	0.030	2450	220	NHXL1602A221MJCG	65
		NHX	105°C 5000H	100 (115)	270	12.5*20	0.08	0.020	2700	270	NHXL2002A271MJCG	65
		NHX	105°C 5000H	100 (115)	330	12.5*23	0.08	0.020	2850	330	NHXL2302A331MJCG	65

# robot

## ROBOT



### Application Requirements

High speed, real-time response; integrated and miniaturized; high precision and high reliability;

### Yongming Capacitor Product Advantages

#### ☑ Ultra-low ESR

Improve the controller's response time to the millisecond level, reduce overall heat generation, and ensure accuracy and directional response

#### ☑ High energy

Miniaturized packaging increases power per unit area while saving space and cost;

#### ☑ Long lifespan

105°C, 10000H lifespan guarantee, extending controller lifespan and significantly reducing maintenance costs;

### Recommended selection (the following are sample specifications for reference only)

Capacitor type	shape	series	Temperature life	Rated Voltage (Surge Voltage) (V)	Nominal capacity (μF)	Product dimensions ΦD*H (mm)	Tan (120HZ)	ESR (Ω/100kHz)	Rated ripple current (mA/100kHz)	LC (μA)	Product Part Number	page number
Liquid aluminum electrolytic capacitors	surface mount type	V3MC	105°C 2000H	35 (40.3)	220	6.3*7.7	0.12	0.240	610	77	V3MCC0771V221MVTM	/
		V3M	105°C 2000H	35 (40.3)	100	6.3*5.8	0.12	0.520	300	35	V3MC0581V101MVTM	15
		V3M	105°C 2000H	50 (62.5)	220	8*10	0.12	0.360	670	110	V3MD1001H221MVTM	15
		V3M	105°C 5000H	100 (125)	220	12.5*16.5	0.12	0.220	1250	220	V3ML1652A221MVTM	15
		VMM	105°C 4000H	80 (92)	68	10*8.4	0.14	2.090	232	54.4	VMME0841K680MV	17
	Lead type	LKE	105°C 10000H	35 (44)	1000	13*20	0.12	0.040	1500	350	LKES2001V102MF	39
		LKE	105°C 10000H	35 (44)	2200	14.5*20	0.14	0.016	2150	770	LKEU2001V222MF	39

Recommended selection (the following are sample specifications for reference only)

Capacitor type	shape	series	Temperature Life	Rated Voltage (Surge Voltage) (V)	Nominal capacity (μF)	Product dimensions ΦDxL (mm)	Tan (120Hz)	ESR (Ω/100kHz)	Rated ripple current (mA/100kHz)	LC (μA)	Product Part Number	page number
Liquid aluminum electrolytic capacitors	Lead type	LKE	105°C 10000H	50 (62, 5)	1000	12, 5*27	0.10	0.058	2520	500	LKEL2701H102MF	39
		LKE	105°C 10000H	80 (100)	1000	14, 5*27	0.09	0.048	2080	800	LKEU2701K102MF	39
		LKE	105°C 10000H	100 (125)	470	14, 5*25	0.09	0.048	2100	470	LKEU2502A471MF	39
		LKE	105°C 10000H	100 (125)	680	14, 5*27	0.09	0.036	2150	680	LKEU2702A681MF	39
		LKM	105°C 10000H	35 (44)	2200	16*20	0.12	0.032	3630	770	LKMI2001V222MF	33
		LKM	105°C 10000H	100 (125)	330	16*20	0.09	0.048	2210	330	LKMI2002A331MF	33
		LKM	105°C 10000H	100 (125)	1000	18*35, 5	0.09	0.029	3510	1000	LKMJ3552A102MF	33
Polymer Hybrid Power Aluminum Electrolytic Capacitor	surface mount type	VHX	105°C 5000H	80 (92)	82	10*8, 5	0.08	0.045	1600	65, 6	VHXE0851K820MVCG	54
		VHX	105°C 5000H	80 (92)	100	10*10, 5	0.08	0.035	1800	80	VHXE1051K101MVCG	54
		VHT	125°C 4000H	80 (92)	82	10*10, 5	0.10	0.035	1200	65, 6	VHTE1051K820MVCG	57
		VHT	125°C 4000H	80 (92)	100	10*10, 5	0.10	0.035	1200	80	VHTE1051K101MVCG	57

# drones

## UAV

IMAGE FOR REFERENCE ONLY.



INDUSTRIAL DRONES



AGRICULTURAL DRONES



MILITARY DRONES

### Application Requirements

Lightweight and integrated; anti-interference and stable;

### Yongming Capacitor Product Advantages

#### High energy

It can achieve lightweight design, centralized configuration, and improved battery life:

#### Ultra-low ESR

Improve the controller's EMI, reduce power consumption, and enhance its survivability in different environments;

#### Long lifespan

The 105°C, 10000H long-life design enhances the overall reliability and stability of the machine.

### Recommended selection (the following are sample specifications for reference only)

Capacitor type	shape	series	Temperature life	Rated Voltage (Surge Voltage) (V)	Nominal capacity (μF)	Product dimensions Φ(D) (mm)	Tan (120HZ)	ESR (Ω/100kHz)	Rated ripple current (mA/100kHz)	LC (μA)	Product Part Number	page number
Liquid aluminum electrolytic capacitors	surface mount type	VMM	105°C 8000H	35 (40.3)	330	10*10	0.18	0.360	630	115	VMME1001V331MVTM	17
		VMM	105°C 4000H	35 (40.3)	220	10*8.4	0.18	0.630	470	35	VMME0841V221MVTM	17
		VMM	105°C 4000H	50 (58)	47	6.3*7.7	0.16	0.680	200	23	VMME0771H470MVTM	17
		VMM	105°C 3000H	63 (72.5)	22	6.3*5.7	0.16	2.600	90	13.8	VMME0571J220MVTM	17
		VMM	105°C 4000H	80 (92)	68	10*8.4	0.14	2.090	232	54.4	VMME0841K680MVTM	17
	Lead type	LKZ	105°C 10000H	16 (20)	220	5*9	0.16	0.950	550	35.2	LKZB0901C221MF	43
		LKZ	105°C 10000H	25 (31)	120	5*9	0.14	1.050	500	30	LKZB0901E121MF	43

Recommended selection (the following are sample specifications for reference only)

Capacitor type	shape	series	Temperature life	Rated Voltage (Surge Voltage) (V)	Nominal capacity ( $\mu$ F)	Product dimensions $\Phi$ D*H (mm)	Tan (120HZ)	ESR ( $\Omega$ /100kHz)	Rated ripple current (mA/100kHz)	LC ( $\mu$ A)	Product Part Number	page number
Liquid aluminum electrolytic capacitors	Lead type	LKE	105°C 10000H	50 (63)	820	14.5*16	0.10	0.058	2480	410	LKEU1601H821MF	39
		LKE	105°C 10000H	63 (79)	1000	14.5*20	0.09	0.018	2180	630	LKEU2001J102MF	39
		LKE	105°C 10000H	63 (79)	1200	14.5*25	0.09	0.020	2420	756	LKEU2501J122MF	39
		LKE	105°C 10000H	63 (79)	1500	14.5*27	0.09	0.039	2540	945	LKEU2501J152MF	39
		LKE	105°C 10000H	100 (125)	220	13*25	0.09	0.066	1620	220	LKES2502A221MF	39
		LKM	105°C 10000H	35 (44)	1200	10*30	0.12	0.032	2600	420	LKME3001V122MF	33
		LKM	105°C 10000H	35 (44)	2200	12.5*30	0.12	0.032	3630	770	LKML3001V222MF	33
		LKM	105°C 10000H	50 (63)	1000	16*25	0.10	0.035	3010	500	LKMI2501H102MF	33
		LKM	105°C 10000H	63 (79)	1200	12.5*35	0.09	0.036	2730	756	LKML3501J122MF	33
		LKM	105°C 10000H	100 (125)	2200	25*25	0.09	0.035	3900	2200	LKMM3602A102MF	33
		LKM	105°C 10000H	100 (125)	1000	18*31.5	0.09	0.029	3510	1000	LKMJ3152A102MF	33
		LKM	105°C 10000H	120 (150)	270	16*20	0.09	0.064	1750	324	LKMI2002K271MF	33
		LKM	105°C 10000H	120 (150)	560	18*31.5	0.09	0.032	2600	672	LKMJ3152K561MF	33
Polymer Hybrid Power Aluminum Electrolytic Capacitor	surface mount type	VHT	125°C 4000H	80 (92)	47	10*10.5	0.10	0.035	1200	37.6	VHTE1051K470MVCG	57
		VHT	125°C 4000H	80 (92)	82	10*13	0.10	0.020	2200	65.6	VHTE1301K820MVCG	57

# power tools

## ELECTRIC TOOLS



ELECTRIC DRILL



ELECTRIC WRENCH



GARDEN TOOLS

### Application Requirements

Reliability; high torque, continuous output; low vibration, low noise;

### Yongming Capacitor Product Advantages

#### ☑ Long lifespan

105°C, 10000H lifespan guaranteed, extending the overall lifespan of the machine;

#### ☑ Ultra-low ESR

Ultra-low ESR design, enhanced overvoltage, overcurrent and overtemperature protection;

#### ☑ Withstands large ripple current

Designed to withstand high ripple current, resulting in less vibration and lower noise; maintains high torque for continuous power output;

### Recommended selection (the following are sample specifications for reference only)

Capacitor type	shape	series	Temperature life	Rated Voltage (Surge Voltage) (V)	Nominal capacity (μF)	Product dimensions ΦD*H (mm)	Tan (120HZ)	ESR (Ω/100kHz)	Rated ripple current (mA/100kHz)	LC (μA)	Product Part Number	page number
Liquid aluminum electrolytic capacitors	surface mount type	VMM	105°C 8000H	35 (40.3)	470	10*13	0.18	0.360	855	164	VMME1301V471MV	17
		VMM	105°C 4000H	35 (40.3)	220	10*8.4	0.18	0.630	470	35	VMME0841V221MVTM	17
		VMM	105°C 4000H	50 (58)	47	6.3*7.7	0.16	0.680	200	23	VMME0771H470MVTM	17
		VMM	105°C 3000H	63 (72.5)	22	6.3*5.7	0.16	2.600	90	13.8	VMME0571J220MVTM	17
		VMM	105°C 3000H	100 (115)	22	10*6.9	0.14	4.900	90	22	VMME0692A220MV	17
	Lead type	LKZ	105°C 10000H	25 (31)	330	6.3*11	0.14	0.4400	1010	82.5	LKZC1101E331MF	43

Recommended selection (the following are sample specifications for reference only)

Capacitor type	shape	series	Temperature Life	Rated Voltage (Surge Voltage) (V)	Nominal capacity ( $\mu$ F)	Product dimensions $\phi$ DiL (mm)	Tan (120Hz)	ESR ( $\Omega$ /100kHz)	Rated ripple current (mA/100Hz)	LC ( $\mu$ A)	Product Part Number	page number
Liquid aluminum electrolytic capacitors	Lead type	LKZ	105°C 10000H	35 (44)	120	5*11	0.12	1.0200	570	42	LKZB1101V121MF	43
		LKZ	105°C 10000H	50 (63)	220	8*11.5	0.12	0.4800	1080	110	LKZD1151H221MF	43
		LKE	105°C 10000H	35 (44)	470	10*16	0.12	0.1150	1000	165	LKEE1601V471MF	39
		LKE	105°C 10000H	35 (44)	1000	13*20	0.12	0.0400	1500	350	LKES2001V102MF	39
		LKE	105°C 10000H	50 (63)	470	13*20	0.10	0.0500	2050	235	LKES2001H471MF	39
		LKE	105°C 10000H	63 (79)	330	13*20	0.09	0.0660	1870	208	LKES2001J331MF	39
		LKE	105°C 10000H	63 (79)	470	13*25	0.09	0.0480	1800	296	LKES2501J471MF	39
		LK	105°C 8000H	100 (125)	470	16*20	0.09	0.0653	1560	470	OLKI2002A471MF	26
		LK	105°C 8000H	100 (125)	560	16*20	0.09	0.0800	1600	560	OLKI2002A561MF	26
		LK	105°C 8000H	100 (125)	820	18*25	0.09	0.0427	2050	820	OLKJ2502A821MF	26
Polymer Hybrid PowerAluminum Electrolytic Capacitor	surface mount type	VHT	125°C 4000H	80 (92)	47	10*10.5	0.10	0.0350	1200	37.6	VHTE1051K470MVCG	57
		VHT	125°C 4000H	80 (92)	82	10*13	0.10	0.0200	2200	65.6	VHTE1301K820MVCG	57

# Automotive thermal management

## AUTOMOTIVE THERMAL MANAGEMENT

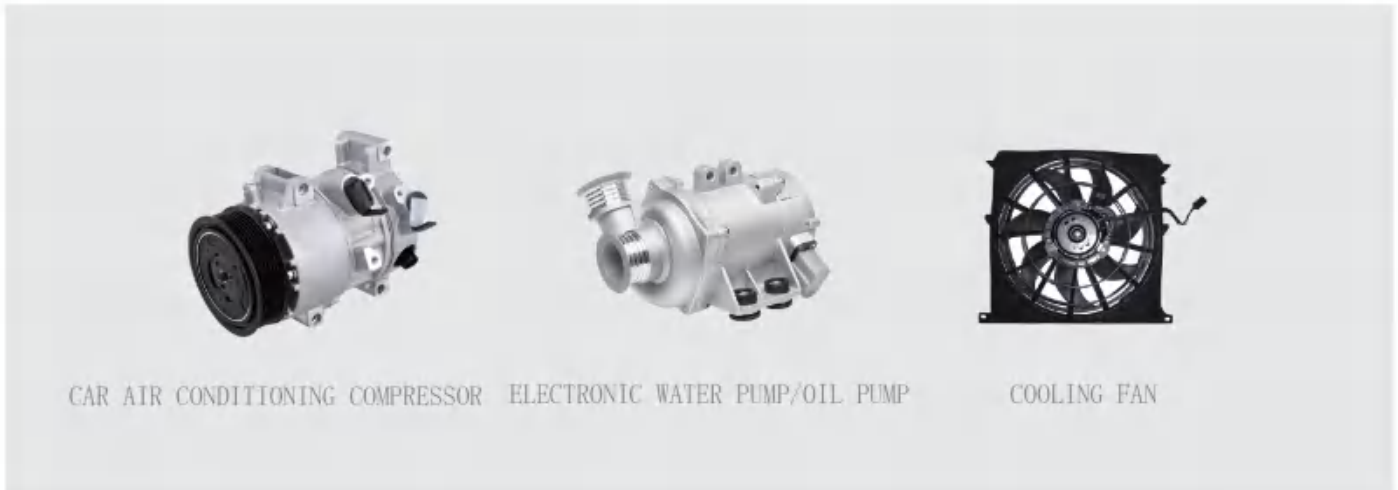

### Application Requirements

Compact and integrated design; high temperature resistance; safety and reliability; shock resistance; high energy efficiency; interference resistance;

### Yongming Capacitor Product Advantages

#### High energy density

It meets the requirements of small overall size, saves PCB space, and is compatible with compact electronic

#### High temperature resistance, long service life

Products that can withstand temperatures up to 135°C can actually last for 6000 hours at 135°C.

#### Ultra-low ESR

Ultra-low ESR and low capacitor temperature rise ensure that the cooling fan can work at high

#### Seismic design

Ensure the capacitor's performance remains stable under long-term vehicle bumps and mechanical

### Recommended selection (the following are sample specifications for reference only)

Capacitor type	shape	series	Temperature Life	Rated Voltage (Surge Voltage) (V)	Nominal capacity (μF)	Product dimensions ΦDxL (mm)	Tan (120HZ)	ESR (Ω/100kHz)	Rated ripple current (mA/100kHz)	LC (μA)	Product Part Number	page number
Liquid aluminum electrolytic capacitors	surface mount type	VKL	125°C 3000H	35 (43.8)	330	10*10	0.16	0.220	750	115	VKLE1001V331MVTMCG	22
		VKL	125°C 3000H	35 (43.8)	470	10*16.5	0.16	0.200	1100	164	VKLE1651V471MVTMCG	22
		VKL	125°C 5000H	80 (92)	220	12.5*21	0.16	0.240	890	176	VKLL2101K221MVTMCG	22
		VKL	125°C 5000H	400 (450)	5.6	10*10	0.16	8.000	130	20	VKLE1002G5R6MVTMCG	22
		VMM	105°C 10000H	450 (500)	15	12.5*13.5	0.20	7.000	225	60	VVML1352W150MVTMCG	17
	Lead type	LKL(R)	135°C 3000H	25 (75)	2200	12.5*25	0.14	0.038	1907	550	LKL(R)L2501E222MFTMCG	51
LKL(R)		135°C 3000H	25 (32)	2200	16*20	0.16	0.040	1500	550	LKL(R)I2001E222MF	51	

Recommended selection (the following are sample specifications for reference only)

Capacitor type	shape	series	Temperature life	Rated Voltage (Surge Voltage) (V)	Nominal capacity ( $\mu$ F)	Product dimensions $\Phi$ D*H (mm)	Tan (120HZ)	ESR ( $\Omega$ /100kHz)	Rated ripple current (mA/100kHz)	LC ( $\mu$ A)	Product Part Number	page number
Liquid aluminum electrolytic capacitors	Lead type	LKL(R)	135°C 3000H	35 (85)	1000	12.5*20	0.12	0.044	1500	350	LKL(R)L2001V102MFTMCG	51
		LKL(R)	135°C 3000H	35 (85)	1300	12.5*20	0.12	0.042	1860	455	LKL(R)L2001V132MFTMCG	51
		LKL(R)	135°C 3000H	35 (44)	2200	18*20	0.14	0.070	2200	770	LKL(R)J2001V222MF	51
		LKL(R)	135°C 3000H	35 (44)	3300	16*25	0.16	0.041	3100	1155	LKL(R)I2501V332MF	51
		LKL(R)	135°C 3000H	50 (63)	560	16*16	0.10	0.078	1000	280	LKL(R)I1601H561MF	51
		LKL(R)	135°C 3000H	50 (58)	620	12.5*20	0.10	0.073	1470	310	LKL(R)L2001H621MFTMCG	51
		LKL(R)	135°C 3000H	80 (100)	220	12.5*20	0.20	0.450	890	176	LKL(R)L2001K221MF	51
Polymer Hybrid Power Aluminum Electrolytic Capacitor	surface mount type	VHT	125°C 4000H	25 (28.8)	470	10*10.5	0.14	0.020	2800	117.5	VHTE1051E471MVCG	57
		VHT	125°C 4000H	25 (28.8)	560	10*10.5	0.14	0.020	2800	140	VHTE1051E561MVCG	57
		VHT	125°C 4000H	35 (41)	330	10*10.5	0.12	0.020	2800	115.5	VHTE1051V331MVCG	57
		VHT	125°C 4000H	35 (41)	470	10*10.5	0.12	0.020	2800	164.5	VHTE1051V471MVCG	57
		VHT	125°C 4000H	35 (41)	560	10*12.5	0.12	0.016	3000	196	VHTE1251V561MVCG	57
		VHT	125°C 4000H	50 (58)	150	10*10.5	0.10	0.025	1600	75	VHTE1051H151MVCG	57
		VHT	125°C 4000H	50 (58)	220	10*13	0.10	0.020	2400	110	VHTE1301H221MVCG	57
		VHT	125°C 4000H	50 (58)	330	12.5*13.5	0.10	0.020	3500	165	VHTL1351H331MVCG	57
		VHE	125°C 4000H	35 (44)	330	10*10.5	0.10	0.013	4600	115.5	VHEE1051V331MVCG	60
		VHE	125°C 4000H	35 (44)	470	10*10.5	0.10	0.013	4600	164.5	VHEE1051V471MVCG	60
		VHR	150°C 2000H	35 (41)	330	10*10.5	0.12	0.025	900	115.5	VHRE1051V331MVCG	63

# Smart home appliances

## SMART HOME APPLIANCES



FLOOR SCRUBBER

ROBOT VACUUM

VACUUM CLEANER

### Application Requirements

Ultra-quiet; integrated design, super strong suction; ultra-fast start-stop;

### Yongming Capacitor Product Advantages

#### ☑ Withstands large ripple

Designed to withstand high ripple current, resulting in less vibration and lower noise;

#### ☑ High energy density

Miniaturized packaging saves PCB space, increases overall power consumption within the same volume, and offers higher integration and richer functionality;

#### ☑ Low ESR

Improve the controller's response time to ensure fast start-up and quick stop upon encountering obstacles;

### Recommended selection (the following are sample specifications for reference only)

Capacitor type	shape	series	Temperature life	Rated Voltage (Surge Voltage) (V)	Nominal capacity (μF)	Product dimensions ΦD×L (mm)	Tan (120HZ)	ESR (Ω/100kHz)	Rated ripple current (mA/100kHz)	LC (μA)	Product Part Number	page number
Liquid aluminum electrolytic capacitors	surface mount type	V3M	105°C 2000H	35 (40.3)	22	4*5.8	0.12	2.000	160	7.7	V3MA0581V220MVTM	15
		V3M	105°C 2000H	35 (40.3)	100	6.3*5.8	0.12	0.520	300	35	V3MC0581V101MVTM	15
		V3MC	105°C 2000H	35 (40.3)	220	6.3*7.7	0.12	0.240	610	77	V3MCC0771V221MVTM	/
		VMM	105°C 3000H	63 (72.5)	22	6.3*5.7	0.16	2.600	90	13.8	VMMC0571J220MVTM	17
		VMM	105°C 8000H	63 (72.5)	220	12.5*13.5	0.16	0.360	900	138	VVML1351J221MVTM	17
	Lead type	LKM	105°C 10000H	16 (20)	1000	10*16	0.16	0.042	1960	160	LKME1601C102MF	33
		LKM	105°C 10000H	25 (31)	220	6.3*11	0.14	0.210	660	55	LKMC1101E221MF	33
		LKM	105°C 10000H	25 (31)	470	8*11.5	0.14	0.098	1330	110	LKMD1151E471MF	33
		LKM	105°C 10000H	35 (44)	1000	10*20	0.12	0.042	2480	350	LKME2001V102MF	33
		LKM	105°C 10000H	50 (62.5)	150	8*11.5	0.10	0.140	950	75	LKMD1151H151MF	33

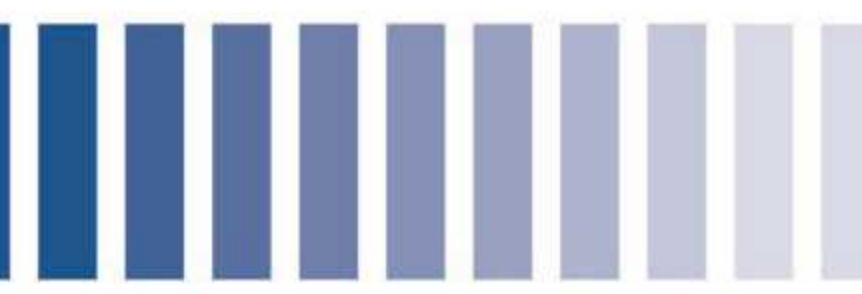

## V3M

- ◆ Low impedance, thin, high capacity V-CHIP products
- ◆ 2000~5000 hours at 105°C
- ◆ Compliant with AEC-Q200 RoHS directive
- ◆ Suitable for high-density, fully automated surface mount technology and high-temperature reflow soldering



### Main technical parameters

project	characteristic												
Operating Temperature Range	$\leq 100V - 55 \sim +105^{\circ}C$ ; $160V - 40 \sim +105^{\circ}C$												
Nominal Voltage Range	6.3~160V												
Capacity Tolerance	$\pm 20\%$ ( $25 \pm 2^{\circ}C$ 120Hz)												
Leakage Current ( $\mu A$ )	6.3~100WV $\leq 0.01CV$ or $3 \mu A$ (whichever is greater) C: Nominal capacitance ( $\mu F$ ) V: Rated voltage (V) Readings taken after 2 minutes												
	160WV $\leq 0.02CV + 10(\mu A)$ C: Nominal Capacity ( $\mu F$ ) V: Rated Voltage (V) Reading after 2 minutes												
Loss Tangent ( $25 \pm 2^{\circ}C$ 120Hz)	Rated voltage (V)	6.3	10	16	25	35	50	63	80	100	160		
	tg $\delta$	0.26	0.19	0.16	0.14	0.12	0.12	0.12	0.12	0.12	0.14		
For nominal capacities exceeding 1000 $\mu F$ , the loss tangent increases by 0.02 for every additional 1000 $\mu F$ .													
Temperature Characteristics (120Hz)	Rated voltage (V)	6.3 10 16 25 35 50 63 80 100 160											
	Impedance ratio $Z(-40^{\circ}C)/Z(20^{\circ}C)$	3 3 3 3 3 3 5 5 5 5											
Durability	After applying the rated voltage for a specified time in a 105°C oven, and then placing it at room temperature for 16 hours, the capacitor is tested at a test temperature of $25 \pm 2^{\circ}C$ . The capacitor's performance should meet the following requirements.												
	Capacity change rate	Within $\pm 30\%$ of the initial value											
	Loss tangent	Below 300% of the specified value											
	Leakage current	Below the specified value											
	Load life	$\leq \Phi 10$ 2000小时					$> \Phi 10$ 5000小时						
High Temperature Storage	After being stored at 105°C for 1000 hours and then placed at room temperature for 16 hours for testing at a test temperature of $25 \pm 2^{\circ}C$ , the capacitor performance should meet the following requirements.												
	Capacity change rate	Within $\pm 30\%$ of the initial value											
	Loss tangent	Below 300% of the specified value											
	Leakage current	Below 200% of the specified value											

### Product dimension drawing (unit: mm)

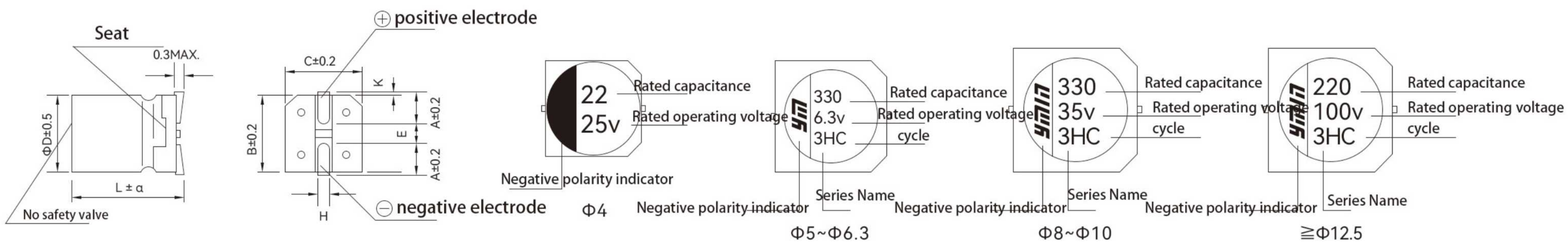

$\Phi D$	L	B	C	A	H	E	K	$\alpha$
4	5.8	4.3	4.3	1.8	0.75±0.20	1.0	0.5MAX	±0.3
5	5.8	5.3	5.3	2.1	0.75±0.20	1.5	0.7MAX	±0.3
6.3	5.8	6.6	6.6	2.6	0.75±0.20	1.8	0.7MAX	±0.3
6.3	7.7	6.6	6.6	2.6	0.75±0.20	1.8	0.7MAX	±0.4
8	10	8.3	8.3	3.0	0.90±0.20	3.1	0.7MAX	±0.5
10	10	10.3	10.3	3.5	0.90±0.20	4.4	0.7MAX	±0.5
12.5	13.5	13	13	4.7	0.90±0.30	4.4	0.7MAX	±1.0
12.5	14.5	13	13	4.7	0.90±0.30	4.4	0.7MAX	±1.0
12.5	16.5	13	13	4.7	0.90±0.30	4.4	0.7MAX	±1.0
12.5	21	13	13	4.7	0.90±0.30	4.4	0.7MAX	±1.0
16	16.5	17	17	5.5	1.20±0.30	6.7	0.70±0.30	±1.0
16	21	17	17	5.5	1.20±0.30	6.7	0.70±0.30	±1.0
18	16.5	19	19	6.7	1.20±0.30	6.7	0.70±0.30	±1.0
18	21	19	19	6.7	1.20±0.30	6.7	0.70±0.30	±1.0

### Frequency correction factor

Frequency (Hz)	50	120	1K	$\geq 10K$
coefficient	0.35	0.50	0.83	1.00



## V3M

### List of Standard Products

Voltage (V)		6.3			10			16			25		
project	Capacity (μF)	Dimensions: ΦD×L (mm)	Impedance (Ωmax/100kHz 25±2°C)	Ripple current (mA r.m.s / 105°C 120Hz)	Dimensions: ΦD×L (mm)	Impedance (Ωmax/100kHz 25±2°C)	Ripple current (mA r.m.s / 105°C 120Hz)	Dimensions: ΦD×L (mm)	Impedance (Ωmax/100kHz 25±2°C)	Ripple current (mA r.m.s / 105°C 120Hz)	Dimensions: ΦD×L (mm)	Impedance (Ωmax/100kHz 25±2°C)	Ripple current (mA r.m.s / 105°C 120Hz)
		22											4×5.8
33											4×5.8	2.00	160
47								4×5.8	2.00	160	5×5.8	0.720	240
68					4×5.8	2.00	160	5×5.8	0.72	240	5×5.8	0.720	240
100		4×5.8	2.00	160				5×5.8	0.72	240	6.3×5.8	0.520	300
150					5×5.8	0.72	240	6.3×5.8	0.52	300	6.3×7.7	0.320	600
220		5×5.8	0.72	240	6.3×5.8	0.52	300	6.3×5.8	0.52	300	6.3×7.7	0.320	600
330		6.3×5.8	0.52	300	6.3×7.7	0.32	600	6.3×7.7	0.32	600			
470		6.3×7.7	0.32	600	6.3×7.7	0.32	600				8×10	0.16	850
680		6.3×7.7	0.32	600				8×10	0.16	850			
820											10×10	0.120	1190
1000					8×10	0.16	850	10×10	0.12	1190			
1500		8×10	0.16	850	10×10	0.12	1190				12.5×13.5	0.116	1420
2200		10×10	0.12	1190									

Voltage (V)		35			50			63			80		
project	Capacity (μF)	Dimensions: ΦD×L (mm)	Impedance (Ωmax/100kHz 25±2°C)	Ripple current (mA r.m.s / 105°C 120Hz)	Dimensions: ΦD×L (mm)	Impedance (Ωmax/100kHz 25±2°C)	Ripple current (mA r.m.s / 105°C 120Hz)	Dimensions: ΦD×L (mm)	Impedance (Ωmax/100kHz 25±2°C)	Ripple current (mA r.m.s / 105°C 120Hz)	Dimensions: ΦD×L (mm)	Impedance (Ωmax/100kHz 25±2°C)	Ripple current (mA r.m.s / 105°C 120Hz)
		10					4×5.8	4.60	85				
10					5×5.8	1.76	165						
22		4×5.8	2.00	160	5×5.8	1.76	165						
33		5×5.8	0.72	240									
47		5×5.8	0.72	240	6.3×5.8	1.36	195						
68		6.3×5.8	0.52	300									
100		6.3×5.8	0.52	300	6.3×7.7	0.68	350						
150		6.3×7.7	0.32	600									
220					8×10	0.36	670				12.5×13.5	0.36	1050
330		8×10	0.16	850	10×10	0.24	900						
470					12.5×13.5	0.24	1340	12.5×16.5	0.28	1250	16×16.5	0.20	1500
560		10×10	0.12	1190									
680								16×16.5	0.164	1740	16×21	0.132	2040
820								18×16.5	0.16	1880	18×21	0.126	2140
1000		12.5×14.5	0.116	1420	16×16.5	0.160	1820						
1200								16×21	0.108	2430			
1500					16×21	0.100	2440						

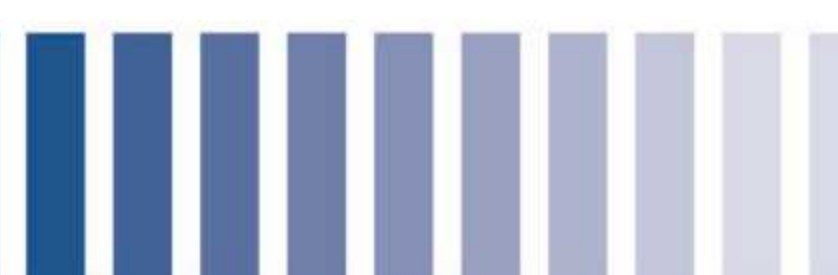

## VMM

- ◆ All-voltage, miniature, flat V-chip products
- ◆ 3000~8000 hours at 105°C
- ◆ Compliant with AEC-Q200 RoHS directive
- ◆ Suitable for high-density, fully automated surface mount technology and high-temperature reflow soldering



### ■ Main technical parameters

project	characteristic								
Operating Temperature Range	≤100V - 55~+105°C ; 160~500V - 40~+105°C								
Nominal Voltage Range	6.3~500V								
Capacity Tolerance	±20% (25±2°C 120Hz)								
Leakage Current (μA)	6.3~100WV I ≤ 0.01CV or 3 μA (whichever is greater) C: Nominal capacitance (μF) V: Rated voltage (V) Readings taken after 2 minutes								
	160~500WV I ≤ 0.02CV+10(μA) C: Nominal capacitance (μF) V: Rated voltage (V) Readings taken over 2 minutes								
Loss Tangent (25 ± 2° C 120Hz)	Rated voltage (V)	6.3	10	16	25	35	50	63	80
	tg δ	0.32	0.28	0.24	0.20	0.18	0.16	0.16	0.14
	Rated voltage (V)	100	160	200	250	350	400	450	500
	tg δ	0.14	0.15	0.15	0.15	0.20	0.20	0.20	0.25
For nominal capacities exceeding 1000 μF, the loss tangent increases by 0.02 for every additional 1000 μF.									
Temperature Characteristics (120Hz)	Rated voltage (V)	6.3	10	16	25	35	50	63	80
	Impedance ratio Z(-40°C)/Z(20°C)	14	12	10	10	10	7	7	7
	Rated voltage (V)	100	160	200	250	350	400	450	500
	Impedance ratio Z(-40°C)/Z(20°C)	7	10	10	10	10	10	10	12
Durability	After applying the rated voltage for a specified time in a 105°C oven, and then placing it at room temperature for 16 hours, the capacitor is tested at a test temperature of 25±2°C. The capacitor's performance should meet the following requirements.								
	Capacity change rate	Within ±30% of the initial value							
	Loss tangent	Below 300% of the specified value							
	Leakage current	Below the specified value							
	Load life	6.3~100WV				160~500WV			
		External Dimensions		Load life		External Dimensions		Load life	
		ΦD*5.7 (6.2, 6.9)		3000		ΦD*5.7 (6.2, 6.9)		3000	
ΦD*7.7 (7.9, 8.4)		4000		ΦD*7.7 (7.9, 8.4)		5000			
Others Φ5~Φ6.3		5000		Others Φ5~Φ6.3		6000			
Others Φ8		6000		Others Φ8		7000			
Others Φ10 and above		8000		Others Φ10 and above		8000			
High Temperature Storage	After applying the rated voltage for a specified time in a 105°C oven, and then placing it at room temperature for 16 hours, the capacitor is tested at a test temperature of 25±2°C. The capacitor's performance should meet the following requirements.								
	Capacity change rate	Within ±20% of the initial value							
	Loss tangent	Below 200% of the specified value							
	Leakage current	Below 200% of the specified value							

## Product dimension drawing (unit: mm)

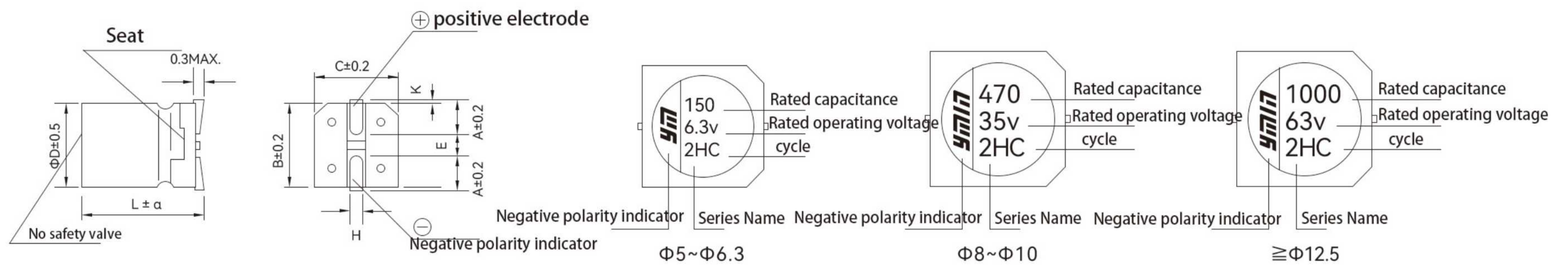

ΦD	L	B	C	A	H	E	K	α
5	5.7	5.3	5.3	2.1	0.75±0.20	1.5	0.7MAX	±0.3
5	7.9	5.3	5.3	2.1	0.75±0.20	1.5	0.7MAX	±0.3
5	10	5.3	5.3	2.1	0.75±0.20	1.5	0.7MAX	±0.5
6.3	5.7	6.6	6.6	2.6	0.75±0.20	1.8	0.7MAX	±0.3
6.3	7.7	6.6	6.6	2.6	0.75±0.20	1.8	0.7MAX	±0.3
6.3	10	6.6	6.6	2.6	0.75±0.20	1.8	0.7MAX	±0.5
8	6.2	8.3	8.3	3.0	0.90±0.20	3.1	0.7MAX	±0.3
8	7.9	8.3	8.3	3.0	0.90±0.20	3.1	0.7MAX	±0.3
8	10	8.3	8.3	3.0	0.90±0.20	3.1	0.7MAX	±0.5
8	12.5	8.3	8.3	3.0	0.90±0.20	3.1	0.7MAX	±0.5
8	14.5	8.3	8.3	3.0	0.90±0.20	3.1	0.7MAX	±0.5
8	16.5	8.3	8.3	3.0	0.90±0.20	3.1	0.7MAX	±0.5
10	6.9	10.3	10.3	3.5	0.90±0.20	4.4	0.7MAX	±0.3
10	8.4	10.3	10.3	3.5	0.90±0.20	4.4	0.7MAX	±0.3
10	10	10.3	10.3	3.5	0.90±0.20	4.4	0.7MAX	±0.5
10	12.5	10.3	10.3	3.5	0.90±0.20	4.4	0.7MAX	±0.5
10	13	10.3	10.3	3.5	0.90±0.20	4.4	0.7MAX	±0.5
10	14.5	10.3	10.3	3.5	0.90±0.20	4.4	0.7MAX	±0.5
10	16.5	10.3	10.3	3.5	0.90±0.20	4.4	0.7MAX	±0.5
10	21	10.3	10.3	3.5	0.90±0.20	4.4	0.7MAX	±0.5
12.5	13.5	13	13	4.7	0.90±0.20	4.4	0.7MAX	±1.0
12.5	14.5	13	13	4.7	0.90±0.20	4.4	0.7MAX	±1.0
12.5	16.5	13	13	4.7	0.90±0.20	4.4	0.7MAX	±1.0
16	16.5	17	17	5.5	1.2±0.30	6.7	0.7±0.30	±1.0
16	21	17	17	5.5	1.2±0.30	6.7	0.7±0.30	±1.0
18	17	19	19	6.7	1.2±0.30	6.7	0.7±0.30	±1.0
18	21	19	19	6.7	1.2±0.30	6.7	0.7±0.30	±1.0

## Frequency correction factor

Frequency (Hz)	50	120	1K	≧10K
coefficient	0.65	1.00	1.37	1.50



category	series	Features	Standard products	Miniaturized products	Long-life products	High temperature resistant products	Low impedance products	AEC-Q200	Customized products	Rated Voltage Range (V)	Rated capacitance range (μF)	Operating temperature range (°C)	Lifespan (Hrs)	page number
Surface mount type	V4M	3.95mm LMAX Ultra-compact Product		●				●		6.3~100	1~220	-55~+105	1000	21
	V3MC	Ultra-high capacitance, low impedance, small size products					●	●		6.3~35	220~2700	-55~+105	2000	23
	V3M	Low impedance, thin, high capacitance products		●				●		6.3~100 160	10~2200	-55~+105 -40~+105	2000~5000	25
	VMM	5mm high thin product		●	●			●		6.3~100 160~500	0.47~4700	-55~+105 -40~+105	3000~8000	28
	VK7	7mm high small products		●	●			●		6.3~100 160~400	1.0~680	-55~+105 -40~+105	4000~6000	35
	VKO	Small size	●					●		10~100 160~500	0.47~10000	-55~+105 -40~+105	6000~8000	38
	VKM	Long lifespan miniaturized products		●	●			●		10~100 160~500	0.47~4700	-55~+105 -40~+105	7000~10000	45
	VKG	Long lifespan		●	●			●		10~100 160~500	0.47~4700	-55~+105 -40~+105	8000~12000	52
	VKL	High temperature resistant, long lifespan products		●	●	●		●		10~100 160~450	0.47~4700	-40~+125 -25~+125	2000~5000	59
	VKL(R)	High temperature resistance, low impedance, and high reliability products		●	●	●	●	●		10~50	47~3300	-55~+135	2000	63
	VKD	Customized products							●	Voltage requirements	Capacity requirements	Temperature requirements	Lifespan requirements	/
	Radial lead type	L3M	Low impedance, thin, high capacitance products		●			●	●		6.3~100 160	10~2200	-55~+105 -40~+105	2000~5000
LMM		thin products		●	●			●		6.3~100 160~500	0.47~4700	-55~+105 -40~+105	3000~8000	67
LK7		7mm high ultra-compact product		●	●			●		6.3~400	1.0~680	-40~+105	5000~6000	72
LK		Small size, high frequency, low impedance	●		●		●	●		10~120 160~500	0.47~10000	-55~+105 -40~+105	6000~8000	75
KCX		Ultra-compact size, lightning-resistant, suitable for fast charging power supplies		●	●		●			400~500	4.7~270	-40~+105	2000~3000	83
KCG <sup>NEW</sup>		High temperature resistance, long lifespan, high voltage, large capacity, and lightning protection.		●		●	●			400	10~120	-40~+105	115°C 2000 105°C 4000	86
KCM <sup>NEW</sup>		Ultra-small size, high pressure resistance		●	●					400~450	8.2~180	-40~+105	3000	88
LKF		Standard products, high frequency, low impedance	●		●		●	●		10~120 160~500	0.47~4700	-55~+105 -40~+105	7000~10000	91
LKM		Long lifespan, miniaturized, high frequency, low impedance		●	●		●	●		10~120 160~500	0.47~4700	-55~+105 -40~+105	7000~10000	99
LKG		Long lifespan, high frequency, low impedance		●	●		●	●		10~120 160~500	0.47~10000	-55~+105 -40~+105	8000~12000	107
LKZ		Long lifespan, high frequency, low impedance		●	●		●	●		10~120 160~600	2.2~6800	-55~+105 -40~+105	12000~15000	115
LLK		Ultra-long lifespan products	●		●		●	●		160~400 450	1.0~68	-40~+105 -25~+105	12000~20000	122
LKX		Long-life pen type	●		●			●		35~100 160~450	12~1800	-55~+105 -40~+105	7000~12000	124
LKL		High temperature resistant, long lifespan products		●	●	●	●	●		10~120 160~500	0.47~8200	-55~+130 -25~+130	2000~5000	128
LKL(R)		High temperature resistant and high reliability products		●	●	●	●	●		10~100	10~12000	-55~+135	3000	133
LKJ		Long lifespan, miniaturized products		●	●		●	●		6.3~100	0.47~15000	-55~+105	5000~10000	136
LKD <sup>NEW</sup>		Small size, large capacity, long lifespan		●	●					400~600	100~560	-40~+105	8000	138
LED <sup>NEW</sup>		High temperature resistant, long life LED-specific products			●	●		●		400~450	2.2~100	-25~+130	130°C 2000 105°C 10000	140
LKE <sup>NEW</sup>		Long life, high frequency, low impedance, dedicated to motor frequency conversion			●		●	●		10~120 160~250	22~10000	-55~+105 -40~+105	10000	142



■ List of Standard Products

Voltage (V)	6.3		10		16		25		35		50	
project	Dimensions: ΦD×L (mm)	Impedance (Ωmax/100kHz 25±2°C)	Dimensions: ΦD×L (mm)	Impedance (Ωmax/100kHz 25±2°C)	Dimensions: ΦD×L (mm)	Impedance (Ωmax/100kHz 25±2°C)	Dimensions: ΦD×L (mm)	Impedance (Ωmax/100kHz 25±2°C)	Dimensions: ΦD×L (mm)	Impedance (Ωmax/100kHz 25±2°C)	Dimensions: ΦD×L (mm)	Impedance (Ωmax/100kHz 25±2°C)
Capacity (μF)												
0.47											5×5.7	4
1.0											5×5.7	8
1.2											5×5.7	9
1.5											5×5.7	10
1.8											5×5.7	11
2.2											5×5.7	12
2.7											5×5.7	14
3.3											5×5.7	16
3.9											5×5.7	18
4.7											5×5.7	20
5.6											5×5.7	22
6.8											5×5.7	24
8.2											5×5.7	26
10	5×5.7	26	5×5.7	26	5×5.7	26	5×5.7	26	5×5.7	26	5×5.7	29
12											5×5.7	32
15	5×5.7	26	5×5.7	26	5×5.7	26	5×5.7	26	5×5.7	26	5×5.7	35
18											5×7.7	40
18											6.3×5.7	55
22	5×5.7	26	5×5.7	26	5×5.7	26	5×5.7	26	5×5.7	26	5×7.7	57
22											6.3×5.7	57
27											6.3×5.7	60
33	5×5.7	30	5×5.7	30	5×5.7	30	5×5.7	30	6.3×5.7	55	6.3×7.7	72
33											8×6.2	72
39	5×5.7	33	5×5.7	33	5×5.7	33	5×7.7	49	6.3×5.7	61	6.3×7.7	80
39											8×6.2	80
47	5×5.7	37	5×5.7	37	5×5.7	37	5×7.7	54	6.3×5.7	67	6.3×7.7	88
47											8×6.2	88
56	5×5.7	40	5×5.7	40	5×7.7	53	5×7.7	60	6.3×7.7	74	8×6.2	100
56					6.3×5.7	53			8×6.2	74		
68	5×5.7	45	5×5.7	45	5×7.7	58	6.3×5.7	100	6.3×7.7	105	8×7.9	120
68					6.3×5.7	58		100	8×6.2	105	10×6.9	120
82	5×5.7	50	6.3×5.7	71	5×7.7	64	6.3×7.7	115	6.3×7.7	116	8×7.9	140
82					6.3×5.7	64	8×6.2	115	8×6.2	116	10×6.9	140
100	5×5.7	55	6.3×5.7	78	6.3×5.7	70	8×6.2	160	8×7.9	160	8×7.9	150
100											10×6.9	150
120	5×5.7	61	6.3×5.7	85	6.3×5.7	77	6.3×7.7	180	8×7.9	180	10×8.4	180
120							8×6.2	180				
150	6.3×5.7	85	6.3×5.7	85	6.3×7.7	109	8×6.2	200	8×7.9	180	10×8.4	220
150					8×6.2	109			10×6.9	210		



■ List of Standard Products

Voltage (V)	6.3		10		16		25		35		50	
project	Dimensions: ΦD×L (mm)	Impedance (Ω <sub>max</sub> /100kHz 25±2°C)	Dimensions: ΦD×L (mm)	Impedance (Ω <sub>max</sub> /100kHz 25±2°C)	Dimensions: ΦD×L (mm)	Impedance (Ω <sub>max</sub> /100kHz 25±2°C)	Dimensions: ΦD×L (mm)	Impedance (Ω <sub>max</sub> /100kHz 25±2°C)	Dimensions: ΦD×L (mm)	Impedance (Ω <sub>max</sub> /100kHz 25±2°C)	Dimensions: ΦD×L (mm)	Impedance (Ω <sub>max</sub> /100kHz 25±2°C)
Capacity (μF)												
180	6.3×5.7	94	6.3×7.7	94	8×6.2	120	8×7.9	170	10×8.4	225	10×10	310
180							10×6.9	225			8×12.5	310
220	6.3×5.7	103	6.3×7.7	103	8×6.2	132	10×6.9	250	10×8.4	315	10×12.5	340
270	6.3×7.7	123	6.3×7.7	163				250	10×8.4	350	10×12.5	375
270	8×6.2	123	8×6.2	163	8×7.9	180	10×8.4	310				
330	8×6.2	135	8×6.2	175					10×10	420	12.5×13.5	415
330	6.3×7.7	135			8×7.9	200	10×8.4	345			10×14.5	415
390	8×6.2	166	8×7.9	196	10×6.9	220			10×12.5	525	12.5×13.5	455
390			10×6.9	196			10×8.4	380				
470	8×7.9	200	8×7.9	210	10×8.4	295	10×10	490	10×13	570	12.5×13.5	500
470	10×6.9	200	10×6.9	210								
560	8×7.9	231	10×8.4	253	10×8.4	325	10×12.5	580	12.5×13.5	586	12.5×14.5	550
560	10×6.9	231										
680	8×7.9	254	10×8.4	275	10×10	420	10×12.5	640	12.5×13.5	640	12.5×16.5	610
680	10×6.9	254										
820	10×8.4	304	10×8.4	345	10×10	465	12.5×13.5	710	12.5×14.5	710	16×16.5	680
820	8×10	304										
1000	10×8.4	362	10×10	450	10×12.5	580	12.5×13.5	780	12.5×16.5	780	16×16.5	680
1000	8×10	362										
1200	8×12.5	430	10×12.5	540	10×13	600	12.5×13.5	860	12.5×16.5	850	18×17	750
1200	10×10	430										
1500	10×12.5	520	10×13	600	12.5×13.5	665	12.5×16.5	925	16×16.5	925	16×21	830
1800	10×12.5	520	12.5×13.5	730	12.5×13.5	730	12.5×16.5	1010	16×16.5	1010	18×21	910
2200	10×13	570	12.5×13.5	800	12.5×14.5	860	16×16.5	1100	18×17	1100		
2700	10×16.5	686	12.5×13.5	810	12.5×16.5	980	16×16.5	1230	18×21	1230		
2700	12.5×13.5	686										
3300	10×16.5	760	12.5×16.5	970	16×16.5	1130	18×17	1350				
3300	12.5×13.5	760										
3900	12.5×14.5	830	12.5×16.5	1060	16×16.5	1250	18×21	1480				
4700	12.5×16.5	910	16×16.5	1360	18×17	1580	18×21	1650				



## ■ List of Standard Products

Voltage (V)	63		80		100		160		200		250	
project	Dimensions: ΦD×L (mm)	Impedance (Ωmax/100kHz 25±2°C)	Dimensions: ΦD×L (mm)	Impedance (Ωmax/100kHz 25±2°C)	Dimensions: ΦD×L (mm)	Impedance (Ωmax/100kHz 25±2°C)	Dimensions: ΦD×L (mm)	Impedance (Ωmax/100kHz 25±2°C)	Dimensions: ΦD×L (mm)	Impedance (Ωmax/100kHz 25±2°C)	Dimensions: ΦD×L (mm)	Impedance (Ωmax/100kHz 25±2°C)
Capacity (μF)												
0.47	5×5.7	4	5×5.7	4	5×5.7	4						
1.0	5×5.7	8	5×5.7	8	5×5.7	8	5×5.7	15	5×5.7	15	5×5.7	15
1.2	5×5.7	9	5×5.7	9	5×5.7	9	5×5.7	18	5×5.7	18	5×5.7	18
1.5	5×5.7	10	5×5.7	10	5×5.7	10	5×5.7	18	5×5.7	18	5×7.7	22
1.8	5×5.7	11	5×5.7	11	5×5.7	11	5×5.7	18	5×7.7	22	5×7.7	22
2.2	5×5.7	12	5×5.7	12	5×5.7	12	5×7.7	20	5×7.7	22	6.3×5.7	22
2.7	5×5.7	14	5×5.7	14	5×5.7	14	5×7.7	22	6.3×5.7	31	6.3×7.7	35
3.3	5×5.7	16	5×5.7	16	5×5.7	16	6.3×5.7	22	6.3×5.7	35	6.3×7.7	35
3.3											8×6.2	35
3.9	5×5.7	18	5×5.7	18	5×5.7	18	6.3×5.7	22	6.3×7.7	40	6.3×7.7	40
3.9									8×6.2	40	8×6.2	40
4.7	5×5.7	20	5×5.7	20	5×5.7	20	6.3×7.7	28	6.3×7.7	45	8×6.2	50
4.7							8×6.2	28	8×6.2	45		
5.6	5×5.7	22	5×5.7	22	5×7.7	22	6.3×7.7	40	8×6.2	50	8×7.9	55
5.6							8×6.2	40			10×6.9	55
6.8	5×5.7	24	5×5.7	24	5×7.7	24	8×6.2	45	8×7.9	65	8×7.9	65
6.8											10×6.9	65
8.2	5×5.7	26	5×7.7	26	6.3×5.7	26	8×6.2	51	8×7.9	65		
8.2									10×6.9	65	10×8.4	80
10	5×5.7	29	5×7.7	28	6.3×5.7	28	8×7.9	56	8×7.9	72		
10							10×6.9	56	10×6.9	72	10×8.4	95
12	5×7.7	45	6.3×5.7	31	6.3×7.7	31	8×7.9	62	8×10	90	10×8.4	105
12	6.3×5.7	45			8×6.2	31	10×6.9	62	10×8.4	90		
15	5×7.7	50	6.3×7.7	38	6.3×7.7	34	8×10	87	10×8.4	105	10×10	125
15	6.3×5.7	50	8×6.2	38	8×6.2	34	10×8.4	87				
18	6.3×5.7	55	6.3×7.7	44	8×6.2	44	10×8.4	95	10×10	125	10×12.5	140
18			8×6.2	44								
22	6.3×5.7	60	6.3×7.7	49	8×7.9	60	10×10	110	10×12.5	180	10×12.5	180
22			8×6.2	60	10×6.9	60						
27	6.3×7.7	65	8×6.2	65	8×7.9	78	10×12.5	150	10×13	225	10×14.5	225
27	8×6.2	65			10×6.9	78						
33	6.3×7.7	72	8×7.9	78	10×8.4	86	10×12.5	165	10×14.5	250	12.5×13.5	270
33	8×6.2	72	10×6.9	78								
39	8×6.2	80	8×7.9	86	10×8.4	110	10×13	185	12.5×13.5	300	12.5×14.5	300
39			10×6.9	86								
47	8×7.9	88	10×8.4	110	10×8.4	140	12.5×13.5	300	12.5×13.5	330	12.5×16.5	375
47	10×6.9	88										
56	8×7.9	98	10×8.4	140	10×10	170	12.5×13.5	330	12.5×14.5	340	12.5×16.5	375
56	10×6.9	98										

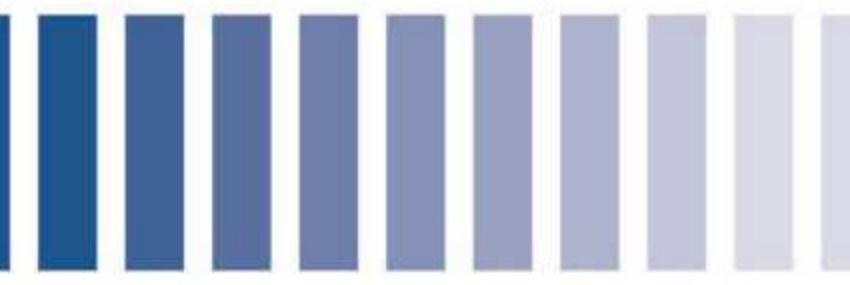

## VKL

- ◆ High temperature resistance, long lifespan, high frequency and high ripple current resistance, designed for high
- ◆ 2000~5000 hours at 125°C
- ◆ Compliant with AEC-Q200 RoHS directive
- ◆ Suitable for high-density, fully automated surface mount technology and high-temperature reflow soldering



### ■ Main technical parameters

project	characteristic							
Operating Temperature Range	≅100V - 40~+125°C ; 160~450V - 25~+125°C							
Nominal Voltage Range	10~450V							
Capacity Tolerance	±20% (25±2°C 120Hz)							
Leakage Current (μA)	10~100WV I≅0.01CV or 3 μA (whichever is greater) C: Nominal capacitance (μF) V: Rated voltage (V) Readings taken after 2 minutes							
	160~450WV I≅0.02CV+10(μA) C: Nominal Capacity (μF) V: Rated Voltage (V) Readings taken over 2 minutes							
Loss Tangent (25 ± 2° C 120Hz)	Rated voltage (V)	10	16	25	35	50	63	80
	tg δ	0.28	0.24	0.20	0.16	0.14	0.14	0.12
	Rated voltage (V)	100	160	200	250	400	450	
	tg δ	0.12	0.15	0.15	0.15	0.20	0.20	
For nominal capacities exceeding 1000 μF, the loss tangent increases by 0.02 for every additional 1000 μF.								
Temperature Characteristics (120Hz)	Rated voltage (V)	10	16	25	35	50	63	80
	Impedance ratio Z(-40°C)/Z(20°C)	6	4	3	3	3	3	3
	Rated voltage (V)	100	160	200	250	400	450	
	Impedance ratio Z(-40°C)/Z(20°C)	3	5	5	5	7	7	
Durability	After applying the rated voltage for a specified time in a 125°C oven, and then placing it at room temperature for 16 hours, the capacitor is tested at a test temperature of 25±2°C. The capacitor's performance should meet the following requirements.							
	Capacity change rate	10~100WV Within ±30% of the initial value						
		160~450WV Within ±20% of the initial value						
	Loss tangent	10~100WV Within ±300% of the initial value						
		160~450WV Within ±200% of the initial value						
	Leakage current	Within the specified value						
Load life	10~100WV			160~450WV				
	External dimensions	Load life		External dimensions	Load life			
	ΦD=5、6.3	2000h		ΦD=5、6.3	2000h			
	ΦD=8、10	3000h		ΦD=8	3000h			
ΦD≧12.5	5000h		ΦD≧10	5000h				
High Temperature Storage	After being stored at 105°C for 1000 hours and then placed at room temperature for 16 hours for testing at a test temperature of 25±2°C, the capacitor performance should meet the following requirements.							
	Capacity change rate	Within ±20% of the initial value						
	Loss tangent	Below 200% of the specified value						
	Leakage current	Below 200% of the specified value						

## Product dimension drawing (unit: mm)

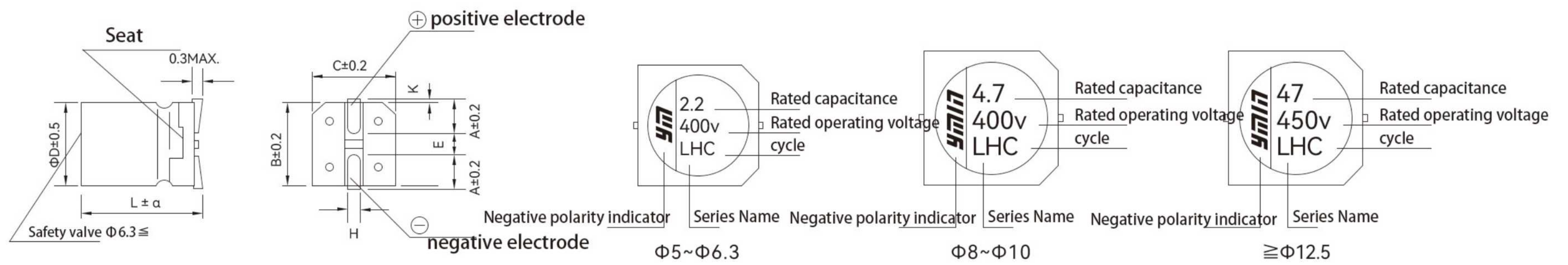

$\Phi D$	L	B	C	A	H	E	K	$\alpha$
5	10	5.3	5.3	2.1	0.75±0.20	1.3	0.7MAX	±0.5
5	12	5.3	5.3	2.1	0.75±0.20	1.3	0.7MAX	±0.5
6.3	10	6.6	6.6	2.6	0.75±0.20	1.8	0.7MAX	±0.5
6.3	12	6.6	6.6	2.6	0.75±0.20	1.8	0.7MAX	±0.5
8	10	8.3	8.3	3.0	0.90±0.20	3.1	0.7MAX	±0.5
8	12.5	8.3	8.3	3.0	0.90±0.20	3.1	0.7MAX	±0.5
8	14.5	8.3	8.3	3.0	0.90±0.20	3.1	0.7MAX	±0.5
8	16.5	8.3	8.3	3.0	0.90±0.20	3.1	0.7MAX	±0.5
8	20.5	8.3	8.3	3.0	0.90±0.20	3.1	0.7MAX	±0.5
10	10	10.3	10.3	3.5	0.90±0.20	4.6	0.7MAX	±0.5
10	13	10.3	10.3	3.5	0.90±0.20	4.6	0.7MAX	±0.5
10	14.5	10.3	10.3	3.5	0.90±0.20	4.6	0.7MAX	±0.5
10	16.5	10.3	10.3	3.5	0.90±0.20	4.6	0.7MAX	±0.5
10	21	10.3	10.3	3.5	0.90±0.20	4.6	0.7MAX	±0.5
12.5	13.5	13.0	13.0	4.7	0.90±0.30	4.4	0.7MAX	±1.0
12.5	14.5	13.0	13.0	4.7	0.90±0.30	4.4	0.7MAX	±1.0
12.5	16.5	13.0	13.0	4.7	0.90±0.30	4.4	0.7MAX	±1.0
12.5	21	13.0	13.0	4.7	0.90±0.30	4.4	0.7MAX	±1.0
16	16.5	17.0	17.0	5.5	1.20±0.30	6.7	0.7±0.30	±1.0
16	21	17.0	17.0	5.5	1.20±0.30	6.7	0.7±0.30	±1.0
18	16.5	19.0	19.0	6.7	1.20±0.30	6.7	0.7±0.30	±1.0
18	21	19.0	19.0	6.7	1.20±0.30	6.7	0.7±0.30	±1.0

## Frequency correction factor

Frequency (Hz)		120	1K	10K	100K $\cong$
coefficient	0.47~8.2	0.42	0.60	0.80	1.00
	10~39	0.45	0.75	0.90	1.00
	47~180	0.50	0.80	0.95	1.00
	220以上	0.60	0.85	0.95	1.00



1 2 3  
↓

series	code
L3M	L3M
LMM	LMM
LK7	LK7
LK	OLK
KCX	KCX
KCG	KCG
KCM	KCM
LKF	LKF
LKM	LKM
LKG	LKG
LKZ	LKZ
LLK	LLK
LKX	LKX
LKL	LKL
LKL(R)	LKL(R)
LKJ	LKJ
LKD	LKD
LED	LED
LKE	LKE
V4M	V4M
V3MC	V3MC
V3M	V3M
VMM	VMM
VK7	VK7
VKO	VKO
VKM	VKM
VKG	VKG
VKL	VKL
VKL(R)	VKL(R)

4 5 6 7  
↓

Product diameter	code	Product Height	code
3.5	F	3.95	039
3.55	W	4.5	045
4	A	5	050
4.5	G	5.4	054
5	B	5.7	057
5.5	H	5.8	058
6.3	C	6.5	065
7	T	7	070
8	D	7.7	077
10	E	8	080
12.5	L	8.5	085
13	S	9	090
14.5	U	9.5	095
16	I	10	100
18	J	10.5	105
20	N	11	110
22	K	11.5	115
25	M	12	120
		12.5	125
		13	130
		13.5	135
		14	140
		14.5	145
		15	150
		16	160
		16.5	165
		17	170
		18	180
		19	190
		20	200
		21	210
		22	220
		23	230
		25	250
		28	280
		30	300
		31.5	315
		32	320
		35.5	355
		36	360
		40	400
		41.5	415
		45	450
		50	500

8 9  
↓

Rated voltage(V)	code
6.3	0J
10	1A
16	1C
20	1D
25	1E
27	1N
35	1V
40	1G
50	1H
63	1J
70	1L
80	1K
90	1F
100	2A
110	2R
120	2K
125	2B
130	1Q
140	2Q
160	2C
180	2M
200	2D
250	2E
270	2N
300	2S
315	2F
320	1U
330	2U
350	2V
375	2P
400	2G
420	2T
450	2W
480	2L
500	2H
550	2I
600	2J
630	2Y
650	2X

10 11 12  
↓

Capacitance(μF)	code
0.1	R10
0.22	R22
0.33	R33
0.47	R47
0.56	R56
0.68	R68
0.82	R82
1.0	1R0
2.2	2R2
3.3	3R3
3.9	3R9
4.7	4R7
5.6	5R6
6.8	6R8
8.2	8R2
10	100
12	120
15	150
22	220
33	330
47	470
56	560
68	680
82	820
100	101
120	121
150	151
180	181
220	221
330	331
470	471
560	561
680	681
820	821
1000	102
1500	152
2200	222
3300	332
4700	472
6800	682
10000	103
22000	223
33000	333

13  
↓

Capacity range	code
±20%	M
±10%	K
0%~+10%	R
0%~-10%	T
-10%~+20%	V
-20%~+5%	L
-10%~+5%	G
-10%~+15%	H
0%~+40%	I
±15%	J
-20%~+50%	A
-5%~-20%	B
-5%~+20%	E
-15%~+5%	C
-15%~-5%	D
0%~+20%	F
0%~+15%	N
-5%~+15%	W
-20%~+0%	S
-20%~+10%	P
0%~+5%	Q
-15%~+20%	u

14  
↓

Subsidiary code (domestic)	
O	Lead Wire 30F/35F
H	Lead Wire 33F/38F
F	Lead Wire 22F/27F
A	Straight Cut Lead Type A
B	Cut & Formed Lead Type B
C	Cut & Formed Lead Type C
D	Cut & Formed Lead Type D
E	Cut & Formed Lead Type E
Q	Cut & 90° Bent Lead Type F-A (Right)
P	Cut & 90° Bent Lead Type F-B (Left)
X	Cut & Formed Lead Type G
g	Cut & Double 90° Bent Lead Type H-A (Right)
f	Cut & Double 90° Bent Lead Type H-B (Left)
K	Taped Type A
J	Taped Type B
V	SMD
TM	Coated
CG	AEC-Q200 / Automotive Grade
TJ	Transparent
SLYP	Plastic Reel
Indicator Code (IND)	
2	Lead Wire 30F/35F
3	Lead Wire 33F/38F
4	Straight Cut Lead Type A
5	Cut & Formed Lead Type B
6	Cut & Formed Lead Type C
7	Cut & Formed Lead Type D
8	Cut & Formed Lead Type E
9	Lead Wire 22F/27F
M	Taped Type A
N	Taped Type B



# VKL

## List of Standard Products

Voltage (V)	80		100		160		200		250		400	
project	Dimensions: ΦD×L (mm)	Ripple current (mA r.m.s / 105°C 120Hz)	Dimensions: ΦD×L (mm)	Ripple current (mA r.m.s / 105°C 120Hz)	Dimensions: ΦD×L (mm)	Ripple current (mA r.m.s / 105°C 120Hz)	Dimensions: ΦD×L (mm)	Ripple current (mA r.m.s / 105°C 120Hz)	Dimensions: ΦD×L (mm)	Ripple current (mA r.m.s / 105°C 120Hz)	Dimensions: ΦD×L (mm)	Ripple current (mA r.m.s / 105°C 120Hz)
Capacity (μF)												
0.47					6.3×10	48	6.3×10	68	6.3×10	68	6.3×10	54
1.0	5×10	32	5×10	32	6.3×10	48	6.3×10	68	6.3×10	68	6.3×10	54
1.5	5×10	32	5×10	32	6.3×10	48	6.3×10	68	6.3×10	68	6.3×10	68
1.8	5×10	32	5×10	32	6.3×10	68	6.3×10	72	6.3×10	81	6.3×10	68
2.2	5×10	45	5×10	45	6.3×10	68	6.3×10	81	6.3×10	81	6.3×10	80
2.7	5×10	45	5×10	45	6.3×10	68	6.3×10	81	6.3×10	81	8×10	100
3.3	5×10	63	5×10	63	6.3×10	72	6.3×10	85	6.3×10	90	8×10	110
3.9	5×10	63	5×10	63	6.3×10	72	6.3×10	90	6.3×12	110	8×12.5	125
4.7	5×10	90	5×10	90	6.3×10	81	6.3×12	110	6.3×12	110	8×12.5	125
4.7									8×10	90	10×10	125
5.6	5×10	90	6.3×10	90	6.3×10	85	8×10	117	8×10	117	8×14.5	130
6.8	5×10	90	6.3×10	90	6.3×12	90	8×10	117	8×10	162	10×13	208
8.2	5×10	90	6.3×10	90	8×10	107	8×12.5	165	8×12.5	165	8×20.5	250
8.2							10×10	160	10×10	160	10×14.5	260
10	6.3×10	108	6.3×10	180	8×10	107	8×14.5	210	8×14.5	210	10×16.5	330
10							10×10	160			12.5×14.5	360
15	6.3×10	180	6.3×12	210	8×12.5	117	8×16.5	210	8×16.5	210	12.5×16.5	410
15			8×10	180								
22	6.3×12	210	8×12.5	230	8×14.5	160	8×20.5	250	8×20.5	250	12.5×21	500
22	8×10	180	10×10	198	10×13	178	10×14.5	250	10×14.5	250		
33	6.3×12	230	8×12.5	280	10×14.5	255	10×21	340	10×21	340	16×21	730
33	8×10	198	10×10	280								
47	8×12.5	280	10×13	350	10×21	400	12.5×21	400	12.5×21	400	18×21	850
47	10×10	280										
56	10×10	280	10×13	350	12.5×16.5	608	12.5×21	500	12.5×21	500		
100	10×16.5	550	12.5×16.5	700	16×21	825	16×21	800	18×21	800		
220	12.5×21	890	16×21	1155								
330	12.5×21	1050	18×21	1400								
470	18×21	1400										

Voltage (V)	450		Voltage (V)	450		Voltage (V)	450		Voltage (V)	450	
project	Dimensions: ΦD×L (mm)	Ripple current (mA r.m.s / 105°C 120Hz)	project	Dimensions: ΦD×L (mm)	Ripple current (mA r.m.s / 105°C 120Hz)	project	Dimensions: ΦD×L (mm)	Ripple current (mA r.m.s / 105°C 120Hz)	project	Dimensions: ΦD×L (mm)	Ripple current (mA r.m.s / 105°C 120Hz)
Capacity (μF)											
0.47	6.3×10	60	2.7	8×10	120	6.8	10×14.5	260	15	12.5×16.5	410
1.0	6.3×10	60	3.3	8×12.5	120	8.2	8×20.5	260	22	12.5×21	500
1.5	6.3×10	60	3.9	8×12.5	130	8.2	10×14.5	260	33	16×21	820
1.8	8×10	84	4.7	8×14.5	130	10	10×16.5	320	47	18×21	980
2.2	8×10	90	5.6	10×13	140	10	12.5×14.5	360			



## VKL

### ■ List of Standard Products

Voltage (V)	10		16		25		35		50		63	
project	Dimensions: ΦD×L (mm)	Ripple current (mA r.m.s / 105°C 120Hz)	Dimensions: ΦD×L (mm)	Ripple current (mA r.m.s / 105°C 120Hz)	Dimensions: ΦD×L (mm)	Ripple current (mA r.m.s / 105°C 120Hz)	Dimensions: ΦD×L (mm)	Ripple current (mA r.m.s / 105°C 120Hz)	Dimensions: ΦD×L (mm)	Ripple current (mA r.m.s / 105°C 120Hz)	Dimensions: ΦD×L (mm)	Ripple current (mA r.m.s / 105°C 120Hz)
Capacity (μF)												
1.0									5×10	32	5×10	32
1.5									5×10	32	5×10	32
1.8									5×10	32	5×10	32
2.2									5×10	45	5×10	45
2.7									5×10	45	5×10	45
3.3									5×10	63	5×10	63
3.9									5×10	63	5×10	63
4.7									5×10	90	5×10	90
5.6									5×10	90	5×10	90
6.8									5×10	94	5×10	94
8.2									5×10	98	5×10	98
10	5×10	72	5×10	72	5×10	72	5×10	81	5×10	98	5×10	108
15									5×10	108	5×10	118
22	5×10	72	5×10	72	5×10	72	5×10	81	6.3×10	170	6.3×10	180
33									6.3×10	245	6.3×12	265
33											8×10	280
47	5×10	114	5×10	114	5×10	114	6.3×10	240	6.3×12	320	8×10	420
47									8×10	330		
56									8×10	330	8×10	420
100	5×10	114	6.3×10	200	6.3×10	240	8×10	324	8×12.5	500	8×16.5	590
100									10×10	550	10×13	590
150	6.3×10	162	6.3×10	240	8×10	324	8×12.5	380				
150	6.3×10	200					10×10	324				
220	6.3×10	324	8×10	324	8×12.5	380	8×12.5	650	10×16.5	940	10×21	860
330	6.3×12	380	8×10	380	8×14.5	650	10×13	850	12.5×16.5	980	12.5×21	1050
330	8×10	324			10×13	650						
470	8×10	620	8×12.5	650	10×13	850	10×16.5	1000	12.5×21	1050	16×21	1570
1000	10×13	1000	10×16.5	1000	10×21	1155	12.5×21	1500	18×21	2290		
2200	12.5×16.5	1500	12.5×21	1500	18×21	2400						
3300	12.5×21	1780	18×21	2400								
4700	18×21	2400										

## LK

◆ Compact size, withstands high frequency and high ripple current, high frequency and low impedance, designed for high-end power supplies

◆ 6000~8000 hours at 105°C

◆ Compliant with AEC-Q200 RoHS directive



### Main technical parameters

project	characteristic								
Operating Temperature Range	≅ 120V - 55~+105°C ; 160~500V - 40~+105°C								
Nominal Voltage Range	10~500V								
Capacity Tolerance	±20% (25±2°C 120Hz)								
Leakage Current (μA)	10~120WV I ≅ 0.01CV or 3 μA (whichever is greater) C: Nominal capacitance (μF) V: Rated voltage (V) Readings taken after 2 minutes								
	160~500WV I ≅ 0.02CV+10(μA) C: Nominal capacitance (μF) V: Rated voltage (V) Readings taken over 2 minutes								
Loss Tangent (25 ± 2° C 120Hz)	Rated voltage (V)	10	16	25	35	50	63	80	100
	tg δ	0.19	0.16	0.14	0.12	0.10	0.09	0.09	0.09
	Rated voltage (V)	120	160	200	250	350	400	450	500
	tg δ	0.09	0.09	0.08	0.08	0.10	0.10	0.12	0.20
For nominal capacities exceeding 1000 μF, the loss tangent increases by 0.02 for every additional 1000 μF.									
Temperature Characteristics (120Hz)	Rated voltage (V)	10	16	25	35	50	63	80	100
	Impedance ratio Z(-40°C)/Z(20°C)	6	4	3	3	3	3	3	3
	Rated voltage (V)	120	160	200	250	350	400	450	500
	Impedance ratio Z(-40°C)/Z(20°C)	5	5	5	5	7	7	7	8
Durability	After being stored at 105°C for 1000 hours and then placed at room temperature for 16 hours for testing at a test temperature of 25±2°C, the capacitor performance should meet the following requirements.								
	Capacity change rate	Within ±20% of the initial value							
	Loss tangent	Below 200% of the specified value							
	Leakage current	Below the specified value							
	Load life	≅ Φ5~Φ6.3		6000h		≅ Φ8		8000h	
High Temperature Storage	After being stored at 105°C for 1000 hours and then placed at room temperature for 16 hours for testing at a test temperature of 25±2°C, the capacitor performance should meet the following requirements.								
	Capacity change rate	Within ±20% of the initial value							
	Loss tangent	Below 200% of the specified value							
	Leakage current	Below 200% of the specified value							

### Product dimension drawing (unit: mm)

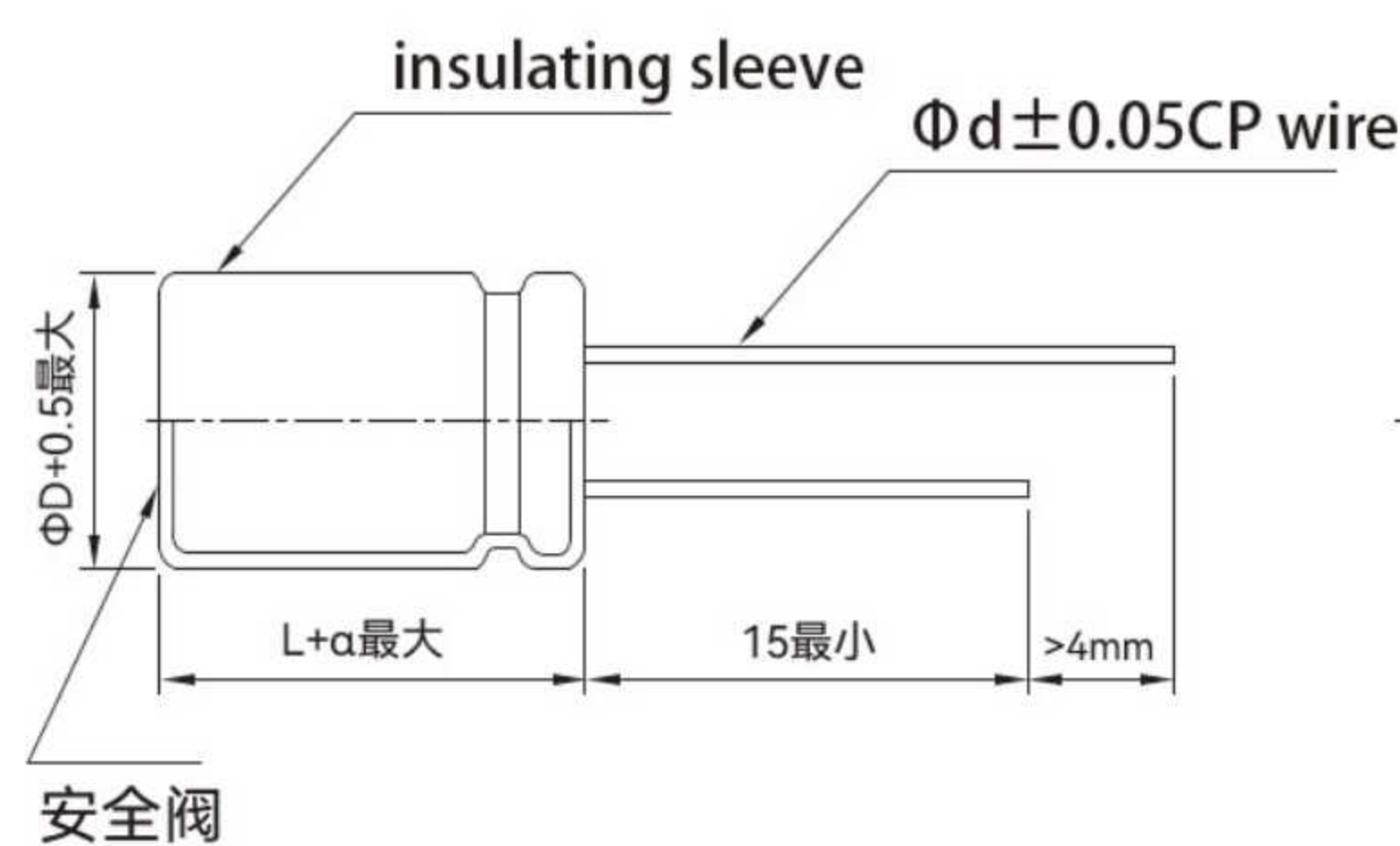

L=9	α=1.0
L≅16	α=1.5
L > 16	α=2.0

D	5	6.3	8	10	12.5~13	12.5~13(高度≧30)	14.5	16	18
d	0.5	0.5	0.6	0.6	0.7	0.6	0.8	0.8	0.8
F	2.0	2.5	3.5	5.0	5.0	5.0	7.5	7.5	7.5

备注: ≧Φ6.3 产品有安全阀

### Ripple current compensation coefficient

#### ① Frequency correction factor

Frequency (Hz)	50	120	1K	10K~50K	100K
Correction Factor	0.40	0.50	0.80	0.90	1.00

#### ② Temperature correction factor

Ambient temperature (°C)	50°C	70°C	85°C	105°C
Correction factor	2.1	1.8	1.4	1.0



## List of Standard Products

Voltage (V)	10			16			25			35		
project	Dimensions: ΦD×L (mm)	Impedance (Ωmax/100kHz 25±2°C)	Ripple current (mA r.m.s / 105°C 120Hz)	Dimensions: ΦD×L (mm)	Impedance (Ωmax/100kHz 25±2°C)	Ripple current (mA r.m.s / 105°C 120Hz)	Dimensions: ΦD×L (mm)	Impedance (Ωmax/100kHz 25±2°C)	Ripple current (mA r.m.s / 105°C 120Hz)	Dimensions: ΦD×L (mm)	Impedance (Ωmax/100kHz 25±2°C)	Ripple current (mA r.m.s / 105°C 120Hz)
Capacity (μF)												
10	5×9	1.10	55	5×9	1.10	70	5×9	1.10	90	5×9	1.60	100
15	5×9	1.10	75	5×9	1.10	90	5×9	1.10	110	5×9	1.10	120
22	5×9	0.42	90	5×9	0.42	110	5×9	1.10	120	5×9	1.10	160
33	5×9	0.42	105	5×9	0.42	120	5×9	0.42	150	5×9	0.42	215
39	5×9	0.42	135	5×9	0.42	150	5×9	0.42	180	5×9	0.42	215
47	5×9	0.28	142	5×9	0.28	160	5×9	0.28	210	5×11	0.38	310
56	5×9	0.28	150	5×9	0.28	170	5×9	0.28	290	5×11	0.38	310
68	5×9	0.28	160	5×9	0.28	180	5×11	0.25	310	6.3×9	0.36	390
82	5×9	0.28	170	5×9	0.28	210	5×11	0.25	310	6.3×9	0.36	390
100	5×9	0.28	180	5×9	0.28	290	5×11	0.25	310	6.3×11	0.17	404
100										8×9	0.17	441
120	5×9	0.28	210	5×11	0.25	310	6.3×9	0.25	390	8×9	0.17	441
150	5×9	0.28	290	6.3×9	0.25	390	6.3×11	0.17	404	8×11.5	0.13	830
150							8×9	0.17	441	10×9	0.13	765
180	5×11	0.28	290	6.3×9	0.25	390	6.3×11	0.17	404	8×11.5	0.13	830
180							8×9	0.17	441	10×9	0.13	765
220	5×11	0.25	310	6.3×11	0.17	404	6.3×11	0.17	404	8×11.5	0.13	830
220				8×9	0.17	441	8×9	0.17	441	10×9	0.13	765
270	6.3×9	0.25	390	6.3×11	0.17	404	8×11.5	0.10	830	8×16	0.10	1150
270				8×9	0.17	441	10×9	0.10	765	10×12.5	0.10	1150
330	6.3×11	0.17	404	6.3×11	0.17	650	8×11.5	0.10	830	8×16	0.10	1170
330	8×9	0.17	441	8×9	0.17	765	10×9	0.10	765	10×12.5	0.10	1150
390	6.3×11	0.17	650	8×11.5	0.10	830	8×14	0.12	1150	8×20	0.0505	1350
390	8×9	0.17	765	10×9	0.10	765	10×12.5	0.10	1150	10×16	0.0505	1550
470	6.3×11	0.17	650	8×11.5	0.10	830	8×16	0.10	1170	8×20	0.0505	1350
470	8×9	0.17	765	10×9	0.10	765	10×12.5	0.10	1150	10×16	0.0505	1550
560	8×11.5	0.10	830	8×11.5	0.10	830	8×20	0.0505	1350	10×16	0.0420	1550
560	10×9	0.10	765	10×9	0.10	765	10×12.5	0.10	1150	12.5×14	0.0500	1808
680	8×11.5	0.10	830	8×16	0.10	1125	8×20	0.0505	1350	10×20	0.0420	1590
680	10×9	0.10	765	10×12.5	0.13	1150	10×16	0.0505	1550	12.5×16	0.0500	1910
820	8×11.5	0.10	830	8×20	0.0505	1350	10×16	0.0505	1550	10×20	0.0420	1590
820				10×14	0.0805	1350	12.5×14	0.0600	1808	12.5×16	0.0500	1910
1000	8×16	0.10	1125	8×20	0.0505	1350	10×20	0.0505	1808	12.5×20	0.0300	2250
1000	10×12.5	0.10	1150	10×14	0.0805	1350	12.5×14	0.0600	1808			
1200	8×16	0.10	1125	10×16	0.0505	1550	10×23	0.0500	2050	10×27	0.0300	2220
1200	10×14	0.0805	1350	12.5×14	0.0600	1808	12.5×16	0.0500	1910	12.5×20	0.0300	2250
1500	8×20	0.0805	1350	10×20	0.0420	1590	12.5×20	0.0300	2250	12.5×25	0.0270	2620
1500	10×14	0.0805	1350	12.5×14	0.0600	1808				16×20	0.0270	2925
1800	10×20	0.0620	1590	10×20	0.0420	1590	12.5×20	0.0300	2250	12.5×35	0.0210	3215

## LKM

◆ Compact size, high frequency and high ripple current withstand, high frequency and low impedance, dedicated power supply product

◆ 7000~10000 hours at 105°C

◆ Compliant with AEC-Q200 RoHS directive



### ■ Main technical parameters

project	characteristic						
Operating Temperature Range	≦120V - 55~+105°C ; 160~500V - 40~+105°C						
Nominal Voltage Range	10~500V						
Capacity Tolerance	±20% (25±2°C 120Hz)						
Leakage Current (μA)	10~120WV I≦0.01CV or 3μA (whichever is greater) C: Nominal capacitance (μF) V: Rated voltage (V) Readings taken after 2 minutes 160~500WV I≦0.02CV+10(μA) C: Nominal capacitance (μF) V: Rated voltage (V) Readings taken over 2 minutes						
Loss Tangent (25 ± 2 ° C 120Hz)	Rated voltage (V) 10 16 25 35 50 63 80 100						
	tg δ 0.19 0.16 0.14 0.12 0.10 0.09 0.09 0.09						
	Rated voltage (V) 120 160 200 250 350 400 450 500						
	tg δ 0.09 0.09 0.08 0.08 0.10 0.10 0.12 0.20						
For nominal capacities exceeding 1000 μF, the loss tangent increases by 0.02 for every additional 1000 μF.							
Temperature Characteristics (120Hz)	Rated voltage (V) 10 16 25 35 50 63 80 100						
	Impedance ratio Z(-40°C)/Z(20°C) 6 4 3 3 3 3 3 3						
	Rated voltage (V) 120 160 200 250 350 400 450 500						
	Impedance ratio Z(-40°C)/Z(20°C) 5 5 5 5 7 7 7 8						
Durability	In a 105°C oven, apply the rated voltage containing the rated ripple current for a specified time, then place at room temperature for 16 hours before testing. The test temperature is 25±2°C. The capacitor's performance should meet the following requirements.						
	Capacity change rate Within ±20% of the initial value						
	Loss tangent Below 200% of the specified value						
	Leakage current Below the specified value						
	Load life	<table border="1"> <tr> <td>Φ5</td> <td>7000h</td> </tr> <tr> <td>Φ6.3</td> <td>9000h</td> </tr> <tr> <td>≧Φ8</td> <td>10000h</td> </tr> </table>	Φ5	7000h	Φ6.3	9000h	≧Φ8
Φ5	7000h						
Φ6.3	9000h						
≧Φ8	10000h						
High Temperature Storage	After being stored at 105°C for 1000 hours and then placed at room temperature for 16 hours for testing at a test temperature of 25±2°C, the capacitor performance should meet the following requirements.						
	Capacity change rate Within ±20% of the initial value						
	Loss tangent Below 200% of the specified value						
	Leakage current Below 200% of the specified value						

### ■ Product dimension drawing (unit: mm)

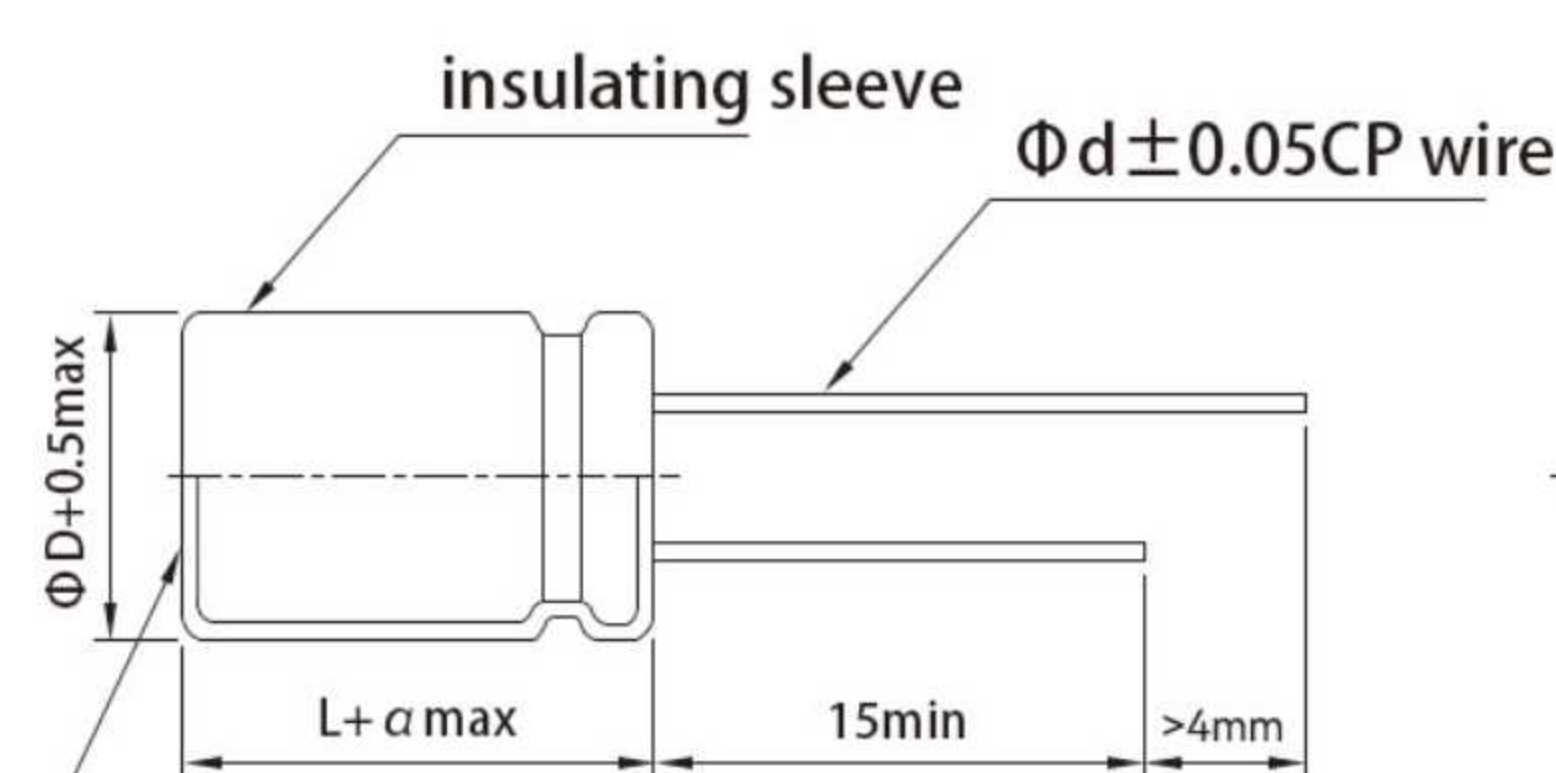

L=9	α=1.0
L≦16	α=1.5
L > 16	α=2.0

D	5	6.3	8	10	12.5~13	12.5~13(h≧30)	14.5	16	18
d	0.5	0.5	0.6	0.6	0.7	0.6	0.8	0.8	0.8
F	2.0	2.5	3.5	5.0	5.0	5.0	7.5	7.5	7.5

safety valve

Note: Products ≧ Φ6.3 have a safety valve.

### ■ Ripple current compensation coefficient

#### ① Frequency correction factor

Frequency (Hz)	50	120	1K	10K~50K	100K
Correction Factor	0.40	0.50	0.80	0.90	1.00

#### ② Temperature correction factor

Ambient temperature (° C)	50°C	70°C	85°C	105°C
Correction factor	2.1	1.8	1.4	1.0

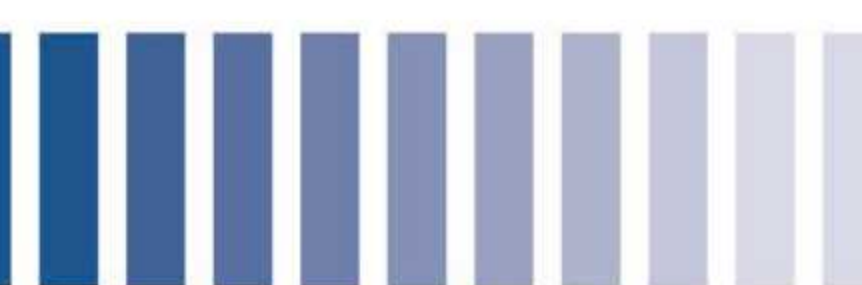

This specification applies to the lead-cutting and tape-forming aluminum electrolytic capacitor products manufactured by our company, including technical requirements, judgment criteria, and acceptance specifications.

Lead cutting and shaping diagram A

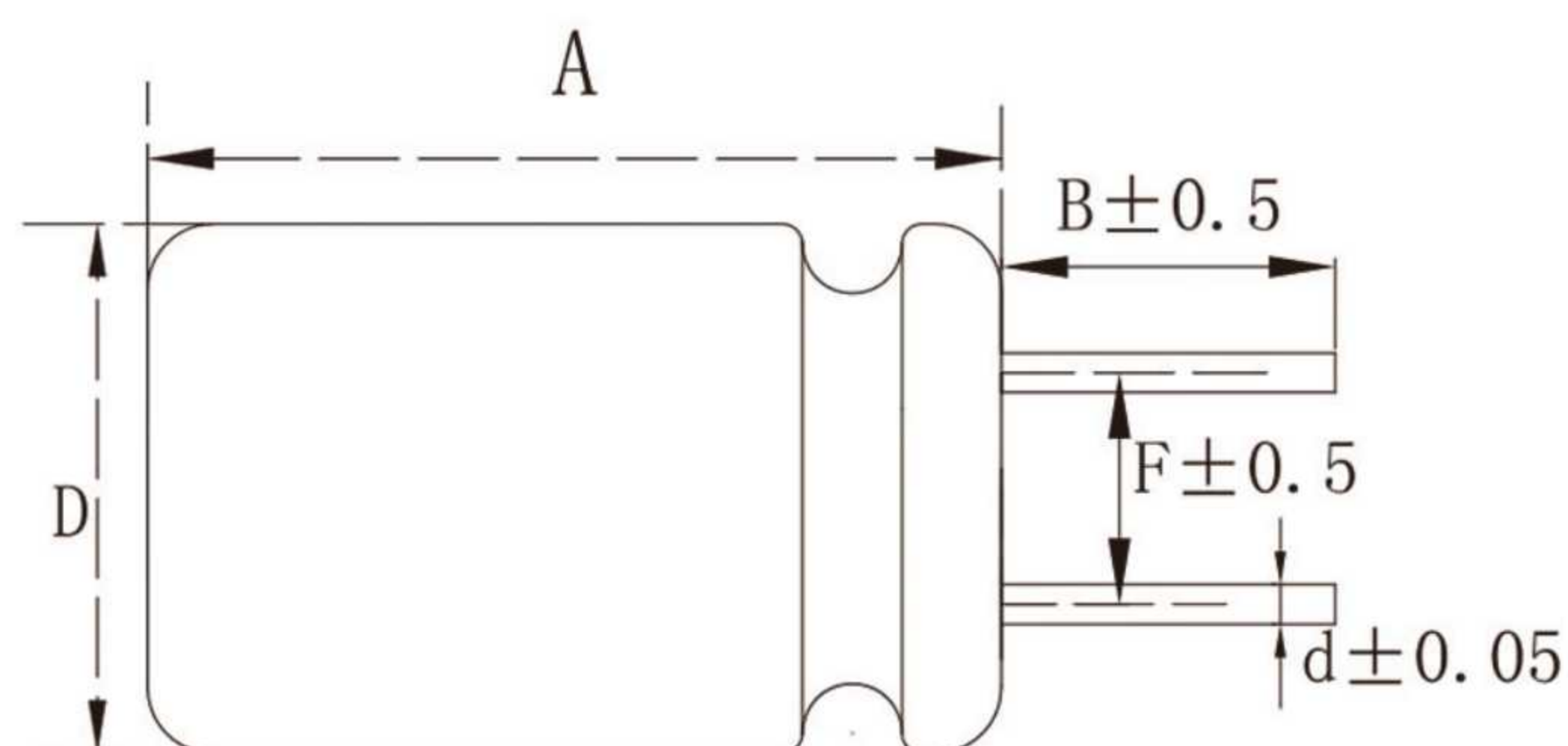

D	5	6.3	8	10	12.5	14.5	16	18	error
B	2.5~10								±0.5
d	0.5		0.6		0.7	0.8			±0.05
F	2.0	2.5	3.5	5.0		7.5			±0.5

Lead cutting and shaping diagram B

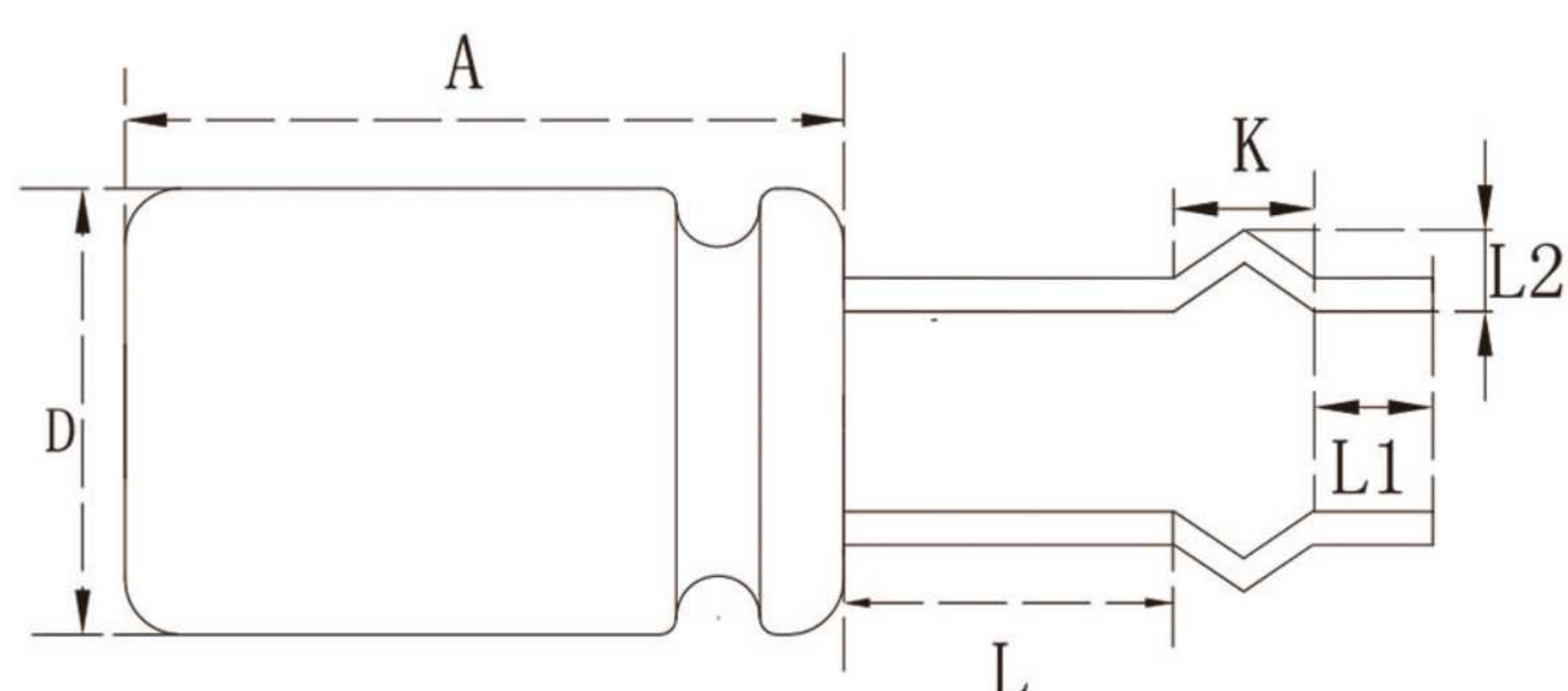

D	A	L±0.5	K±0.5	L2±0.3	L1±0.5	Notes
≤Φ14.5	≤25	2.5~22	2.5	1.5	2.5~5.0	Outer K molding

Lead cutting and shaping diagram c

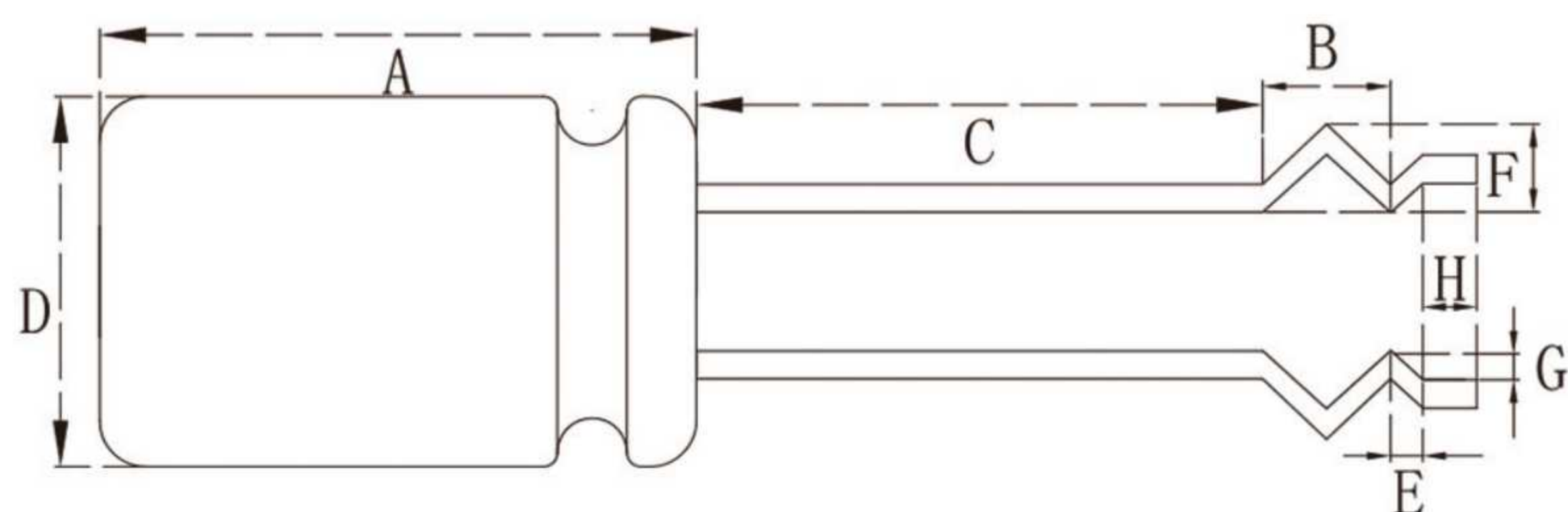

D	A	C±0.5	B±0.5	E±0.3	F±0.3	G±0.3	H±0.5	Notes
≤Φ14.5	≤25	2.5~22	3.0	1.2	1.8	0.8	2.0~5.0	Internal and external K-forming

Lead cutting and shaping diagram D

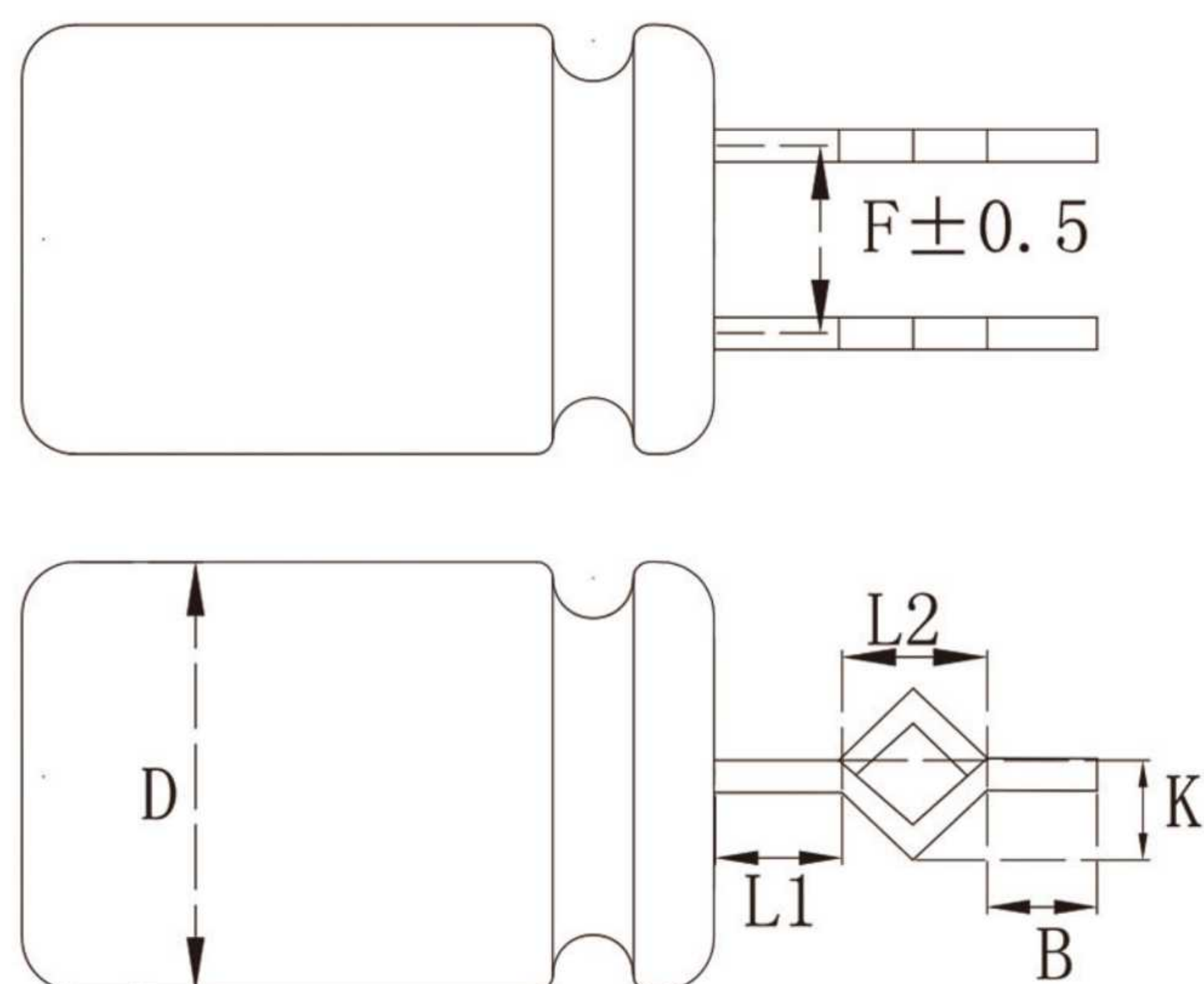

ΦD	8	error
F	3.5	±0.5
L1	2.5~21.0	±0.5
L2	3.5	±0.5
K	1.2	±0.2
B	1.2	±0.5



## List of Standard Products

Voltage (V)	10			16			25			35		
project Capacity (μF)	Dimensions: ΦD×L (mm)	Impedance (Ωmax/100kHz 25±2°C)	Ripple current (mA r.m.s / 105°C 120Hz)	Dimensions: ΦD×L (mm)	Impedance (Ωmax/100kHz 25±2°C)	Ripple current (mA r.m.s / 105°C 120Hz)	Dimensions: ΦD×L (mm)	Impedance (Ωmax/100kHz 25±2°C)	Ripple current (mA r.m.s / 105°C 120Hz)	Dimensions: ΦD×L (mm)	Impedance (Ωmax/100kHz 25±2°C)	Ripple current (mA r.m.s / 105°C 120Hz)
10	5×9	1.10	56	5×9	1.10	71	5×9	1.10	91	5×9	1.40	101
15	5×9	1.10	76	5×9	1.10	91	5×9	1.10	111	5×9	1.10	121
22	5×9	0.40	91	5×9	0.40	111	5×9	1.10	121	5×9	1.10	160
33	5×9	0.40	106	5×9	0.40	121	5×9	0.40	151	5×9	0.40	215
39	5×9	0.26	136	5×9	0.40	151	5×9	0.40	181	5×9	0.40	345
47	5×9	0.26	143	5×9	0.26	161	5×9	0.26	211	5×9	0.37	345
56	5×9	0.26	151	5×9	0.26	171	5×9	0.26	310	5×9	0.37	414
68	5×9	0.26	161	5×9	0.26	181	5×9	0.24	345	5×11	0.34	443
68										6.3×9	0.34	486
82	5×9	0.26	171	5×9	0.26	211	5×9	0.34	414	5×11	0.28	486
82										6.3×9	0.28	540
100	5×9	0.26	181	5×9	0.24	345	5×9	0.34	443	6.3×9	0.28	550
120	5×9	0.26	211	5×9	0.24	345	5×11	0.34	486	6.3×9	0.28	550
120							6.3×9	0.28	486			
150	5×9	0.26	345	5×9	0.34	414	6.3×9	0.28	540	6.3×11	0.21	660
150										8×9	0.21	660
180	5×9	0.26	345	5×11	0.34	443	6.3×9	0.28	550	8×9	0.21	900
180				6.3×9	0.34	486						
220	5×9	0.34	414	6.3×9	0.28	540	6.3×11	0.21	660	8×9	0.15	945
220							8×9	0.21	660			
270	5×11	0.34	443	6.3×9	0.28	540	8×9	0.15	900	8×11.5	0.1200	1250
270	6.3×9	0.34	486							10×9	0.1200	1250
330	6.3×9	0.15	540	6.3×11	0.21	550	8×9	0.1500	945	8×14	0.0900	1330
330				8×9	0.21	550				10×12.5	0.0900	1330
390	6.3×9	0.15	540	8×9	0.15	660	8×11.5	0.0980	1250	8×16	0.076	1420
390							10×9	0.0980	1250	10×12.5	0.076	1760
470	6.3×11	0.15	545	8×9	0.15	900	8×11.5	0.0980	1330	10×14	0.0590	1850
470	8×9	0.15	550				10×9	0.0980	1330			
560	6.3×11	0.12	880	8×9	0.15	900	8×14	0.0760	1420	10×14	0.0590	1960
560	8×9	0.12	900				10×12.5	0.0760	1760			
680	8×9	0.12	900	8×11.5	0.0980	1250	8×16	0.0590	1500	10×16	0.0520	2120
680				10×9	0.0980	1330	10×12.5	0.0590	1760	12.5×14	0.0520	2120
820	8×9	0.12	1180	8×14	0.0760	1420	10×14	0.0460	1850	12.5×14	0.0520	2360
820				10×12.5	0.0760	1760						
1000	8×11.5	0.0980	1250	8×16	0.0590	1500	10×16	0.0420	1960	12.5×16	0.0420	2480
1000	10×9	0.0980	1330	10×12.5	0.0590	1850	12.5×14	0.0420	2120			
1200	8×14	0.0760	1420	10×14	0.0460	1850	10×20	0.0320	2120	12.5×20	0.0380	2900
1200	10×12.5	0.0760	1760				12.5×14	0.0320	2120			
1500	8×16	0.0590	1500	10×16	0.0420	1960	10×20	0.0280	2480	12.5×20	0.0380	2900



# LKM

## List of Standard Products

Voltage (V)	10			16			25			35		
project	Dimensions: ΦD×L (mm)	Impedance (Ωmax/100kHz 25±2°C)	Ripple current (mA r.m.s / 105°C 120Hz)	Dimensions: ΦD×L (mm)	Impedance (Ωmax/100kHz 25±2°C)	Ripple current (mA r.m.s / 105°C 120Hz)	Dimensions: ΦD×L (mm)	Impedance (Ωmax/100kHz 25±2°C)	Ripple current (mA r.m.s / 105°C 120Hz)	Dimensions: ΦD×L (mm)	Impedance (Ωmax/100kHz 25±2°C)	Ripple current (mA r.m.s / 105°C 120Hz)
Capacity (μF)												
1500	10×12.5	0.0590	1760	12.5×14	0.0420	2120	12.5×16	0.0280	2480	16×16	0.0380	3250
1800	10×14	0.0460	1850	10×20	0.0380	1960	12.5×16	0.0280	2480	12.5×25	0.0350	3450
1800				12.5×14	0.0420	2120				14.5×16	0.0210	3180
1800										16×20	0.0350	3630
2200	10×16	0.0420	1960	10×20	0.0380	2480	12.5×20	0.0270	2900	12.5×30	0.0320	3630
2200	12.5×14	0.0420	2120	12.5×16	0.0380	2480	14.5×16	0.0270	2620	14.5×20	0.0160	3215
2200							16×16	0.0270	3250	16×20	0.0320	3630
2700	10×20	0.0320	2250	12.5×16	0.0380	2480	12.5×25	0.0265	3450	14.5×23	0.0160	3320
2700	12.5×14	0.0320	2250				16×20	0.0265	3630	16×25	0.0230	3890
2700										18×20	0.0230	4010
3300	10×23	0.0280	2480				12.5×30	0.0260	3630			
3300	12.5×16	0.0280	2480	12.5×20	0.0280	2900	14.5×20	0.0250	3180	14.5×25	0.0150	3400
3300				14.5×16	0.0268	2620	14.5×23	0.0240	3270	16×31.5	0.0100	4080
3300							16×20	0.0260	3630	18×25	0.0100	4080
3900	12.5×16	0.0280	2900	12.5×25	0.0230	3250	14.5×25	0.023	3350	14.5×27	0.0140	3520
3900				16×16	0.0230	3450	16×25	0.0171	3890			
3900							18×20	0.0171	3650	18×25	0.0100	4080
4700	12.5×20	0.0230	3250	12.5×25	0.0210	3450	14.5×27	0.0220	3460			
4700	14.5×16	0.0280	2450	14.5×20	0.0255	3110	16×25	0.0121	3890			
4700	16×16	0.0230	3450	16×20	0.0210	3630	18×20	0.0110	4010			
5600				14.5×23	0.0250	3200						
6800	14.5×20	0.0180	2780	14.5×25	0.0246	3270						
8200	14.5×23	0.0170	2920									
8200	14.5×25	0.0160	3160									
10000	14.5×27	0.0150	3280	14.5×27	0.0238	3450						

Voltage (V)	50			63			80			100		
project	Dimensions: ΦD×L (mm)	Impedance (Ωmax/100kHz 25±2°C)	Ripple current (mA r.m.s / 105°C 120Hz)	Dimensions: ΦD×L (mm)	Impedance (Ωmax/100kHz 25±2°C)	Ripple current (mA r.m.s / 105°C 120Hz)	Dimensions: ΦD×L (mm)	Impedance (Ωmax/100kHz 25±2°C)	Ripple current (mA r.m.s / 105°C 120Hz)	Dimensions: ΦD×L (mm)	Impedance (Ωmax/100kHz 25±2°C)	Ripple current (mA r.m.s / 105°C 120Hz)
Capacity (μF)												
0.47	5×9	5.50	21	5×9	5.00	23	5×9	6.05	24	5×9	6.05	24
1.0	5×9	5.50	31	5×9	5.00	35	5×9	6.05	37	5×9	6.05	37
1.2				5×9	5.00	35	5×9	6.05	37	5×9	6.05	37
1.5				5×9	5.00	41	5×9	6.05	43	5×9	6.05	43
1.8	5×9	5.50	32	5×9	5.00	41	5×9	6.05	43	5×9	6.05	43
2.2	5×9	1.50	39	5×9	1.50	45	5×9	1.50	47	5×9	1.60	47
2.7				5×9	1.50	52	5×9	1.50	55	5×9	1.60	55
3.3	5×9	1.50	54	5×9	1.50	59	5×9	1.50	62	5×9	1.60	62
3.9	5×9	1.50	54	5×9	1.50	78	5×9	1.50	81	5×9	1.60	81
4.7	5×9	1.50	89	5×9	1.50	98	5×9	1.50	101	5×9	1.60	101
5.6	5×9	1.50	91	5×9	1.50	100	5×9	1.50	106	5×9	1.40	106
6.8	5×9	1.50	94	5×9	1.50	103	5×9	1.50	111	5×9	1.40	111
8.2	5×9	1.50	98	5×9	1.50	109	5×9	1.50	121	5×9	1.40	121
10	5×9	1.50	101	5×9	1.50	111	5×9	1.40	150	5×9	0.80	220
12				5×9	1.50	121	5×9	1.40	163	5×11	0.80	267
12										6.3×9	0.80	267
15	5×9	1.50	121	5×9	1.50	150	5×9	1.10	200	5×11	0.80	267
15										6.3×9	0.80	267
18				5×9	1.1	173	5×9	0.86	240	6.3×9	0.63	267



## List of Standard Products

Voltage (V)	50			63			80			100		
project	Dimensions: ΦD×L (mm)	Impedance (Ωmax/100kHz 25±2°C)	Ripple current (mA r.m.s / 105°C 120Hz)	Dimensions: ΦD×L (mm)	Impedance (Ωmax/100kHz 25±2°C)	Ripple current (mA r.m.s / 105°C 120Hz)	Dimensions: ΦD×L (mm)	Impedance (Ωmax/100kHz 25±2°C)	Ripple current (mA r.m.s / 105°C 120Hz)	Dimensions: ΦD×L (mm)	Impedance (Ωmax/100kHz 25±2°C)	Ripple current (mA r.m.s / 105°C 120Hz)
Capacity (μF)												
22	5×9	1.10	238	5×9	0.86	228	5×11	0.73	250	6.3×9	0.63	290
22							6.3×9	0.63	267			
27	5×9	0.86	286	5×9	0.58	250	6.3×9	0.63	267	6.3×11	0.63	420
27										8×9	0.63	450
33	5×9	0.58	314	5×11	0.39	300	6.3×9	0.63	267	8×9	0.40	450
33				6.3×9	0.39	344						
39	5×11	0.36	344	6.3×9	0.39	344	6.3×11	0.63	400	8×9	0.28	565
39	6.3×9	0.36	344				8×9	0.63	420			
47	5×11	0.36	344	6.3×9	0.39	385	6.3×11	0.63	420	8×11.5	0.28	585
47	6.3×9	0.34	385				8×9	0.63	470	10×9	0.28	624
56	6.3×9	0.34	385	6.3×11	0.24	492	8×9	0.63	470	8×14	0.25	624
56				8×9	0.24	525				10×9	0.25	624
68	6.3×9	0.34	390	6.3×11	0.24	724	8×9	0.49	520	8×16	0.21	735
68				8×9	0.24	724				10×12.5	0.21	750
82	6.3×11	0.24	487	8×9	0.24	724	8×11.5	0.38	624	8×16	0.19	780
82	8×9	0.24	724				10×9	0.25	668	10×14	0.19	900
100	6.3×11	0.18	687	8×9	0.24	902	8×14	0.21	735	10×14	0.14	1040
100	8×9	0.18	724				10×9	0.19	744			
120	8×9	0.18	800	8×11.5	0.19	902	8×16	0.19	744	10×16	0.12	1170
120				10×9	0.19	979	10×12.5	0.19	892	12.5×14	0.12	1240
150	8×11.5	0.14	950	8×14	0.19	950	10×14	0.15	980	12.5×14	0.0930	1368
150	10×9	0.14	975	10×12.5	0.19	1130						
180	8×14	0.11	1190	8×16	0.19	1190	10×14	0.15	980	12.5×16	0.0660	1530
180	10×12.5	0.11	1230	10×14	0.19	1190						
220	8×14	0.0950	1190	10×14	0.14	1200	10×16	0.13	1040	12.5×20	0.0660	1620
220	10×12.5	0.0950	1230				12.5×14	0.13	1040			
270	8×16	0.0740	1420	10×16	0.0860	1300	10×20	0.0940	1240	12.5×20	0.0560	1750
270	10×14	0.0740	1420	12.5×14	0.0902	1500	12.5×16	0.0940	1240	16×16	0.0640	1750
330	10×14	0.0740	1450	10×16	0.0860	1580	12.5×16	0.0940	1368	12.5×25	0.0470	2140
330				12.5×14	0.0902	1650				16×20	0.0480	2210
390	10×16	0.0580	1580	10×20	0.0660	1870	12.5×20	0.0640	1640	12.5×30	0.0400	2210
390	12.5×14	0.0580	1650	12.5×16	0.0660	1870	16×16	0.0640	1750	16×20	0.0480	2210
470	12.5×14	0.0580	2050	12.5×16	0.0500	2100	12.5×20	0.0640	1750			
470							14.5×16	0.076	1460	16×25	0.0480	2400
470							16×16	0.0480	1750	18×20	0.0420	2270
560	12.5×16	0.0500	2050	12.5×20	0.0473	2410	12.5×25	0.0480	2110	16×25	0.0320	2600
560				16×16	0.0473	2500	16×20	0.0480	2110			
680	12.5×16	0.0500	2250	12.5×25	0.0473	2410	12.5×30	0.0420	2270			
680				14.5×16	0.0560	1620	14.5×20	0.0630	1720			
680							14.5×23	0.0570	1860	16×31.5	0.0300	2860
680				16×16	0.0385	2730	16×20	0.0420	2270	18×25	0.0300	2860
820	12.5×20	0.0390	2410	12.5×30	0.0360	2620				14.5×25	0.0520	1990
820	14.5×16	0.0580	2480				16×25	0.0320	2600	18×31.5	0.0290	3510

# LKM

## List of Standard Products

Voltage (V)	50			63			80		
project Capacity (μF)	Dimensions: ΦD×L (mm)	Impedance (Ωmax/100kHz 25±2°C)	Ripple current (mA r.m.s / 105°C 120Hz)	Dimensions: ΦD×L (mm)	Impedance (Ωmax/100kHz 25±2°C)	Ripple current (mA r.m.s / 105°C 120Hz)	Dimensions: ΦD×L (mm)	Impedance (Ωmax/100kHz 25±2°C)	Ripple current (mA r.m.s / 105°C 120Hz)
820	16×16	0.0390	2730	16×20	0.0350	2730	18×20	0.0420	2270
1000	12.5×25	0.0390	2860	14.5×20	0.0480	2180	14.5×27	0.0480	2080
1000				14.5×23	0.0440	2300	16×31.5	0.0300	2860
1000	16×16	0.0390	3010	16×20	0.0350	2860	18×25	0.0340	2470
1200	12.5×25	0.0340	3280	14.5×25	0.0420	2420			
1200	14.5×20	0.0480	2580	16×25	0.0340	2990			
1200	16×20	0.0340	3300	18×20	0.0340	3300	18×25	0.0300	2860
1500	12.5×30	0.0260	3280						
1500	14.5×23	0.0390	2620						
1500	14.5×25	0.0300	2680	14.5×27	0.0390	2540			
1500	16×25	0.0340	3300	16×25	0.0280	3280	18×31.5	0.0290	3510
1800	16×25	0.0280	3300	16×31.5	0.0280	3570			
1800	18×20	0.0280	3300	18×25	0.0280	3570			
2200	14.5×27	0.0280	2780						
2200	18×25	0.0280	3570	18×31.5	0.0260	3670			
2700	18×31.5	0.0260	3670						

Voltage (V)	120			160			200			250		
project Capacity (μF)	Dimensions: ΦD×L (mm)	Impedance (Ωmax/100kHz 25±2°C)	Ripple current (mA r.m.s / 105°C 120Hz)	Dimensions: ΦD×L (mm)	Impedance (Ωmax/100kHz 25±2°C)	Ripple current (mA r.m.s / 105°C 120Hz)	Dimensions: ΦD×L (mm)	Impedance (Ωmax/100kHz 25±2°C)	Ripple current (mA r.m.s / 105°C 120Hz)	Dimensions: ΦD×L (mm)	Impedance (Ωmax/100kHz 25±2°C)	Ripple current (mA r.m.s / 105°C 120Hz)
0.47	5×9	6.05	24									
1.0	5×9	6.05	37	5×9	28.00	68	5×9	28.00	50	5×9	28.00	56
1.2	5×9	6.05	37	5×9	28.00	68	5×9	28.00	55	5×9	28.00	56
1.5	5×9	6.05	43	5×9	28.00	95	5×9	28.00	60	5×9	28.00	56
1.8	5×9	6.05	43	5×9	28.00	95	5×9	28.00	65	5×9	28.00	65
2.2	5×9	1.60	47	5×9	28.00	95	5×9	28.00	75	5×9	28.00	98
2.7	5×9	1.60	55	5×9	28.00	95	5×9	28.00	80	5×9	28.00	98
3.3	5×9	1.60	62	5×9	28.00	95	5×9	28.00	95	5×9	28.00	98
3.9	5×9	1.60	81	5×9	28.00	95	5×9	28.00	95	5×11	23.00	114
3.9										6.3×9	15.60	135
4.7	5×9	1.60	101	5×9	23.00	95	5×11	23.00	104	6.3×9	15.60	135
4.7							6.3×9	15.60	125			
5.6	5×9	1.60	106	5×11	23.00	104	6.3×9	15.60	125	6.3×9	15.60	140
5.6				6.3×9	23.00	110						
6.8	5×11	1.40	111	6.3×9	18.00	125	6.3×9	15.60	140	6.3×11	14.90	140
6.8										8×9	14.90	140
8.2	5×11	1.40	127	6.3×9	18.00	125	6.3×11	14.90	140	6.3×12	12.50	150
8.2							8×9	14.90	140	8×9	12.50	170
10	6.3×9	1.10	220	6.3×11	15.00	132	6.3×12	12.50	160	8×9	10.00	210
10				8×9	15.00	140	8×9	12.50	170			
12	6.3×9	1.10	220	6.3×12	12.50	140	8×11.5	7.00	210	8×11.5	7.00	270



■ List of Standard Products

Voltage (V)	120			160			200			250		
project	Dimensions: ΦD×L (mm)	Impedance (Ωmax/100kHz 25±2°C)	Ripple current (mA r.m.s / 105°C 120Hz)	Dimensions: ΦD×L (mm)	Impedance (Ωmax/100kHz 25±2°C)	Ripple current (mA r.m.s / 105°C 120Hz)	Dimensions: ΦD×L (mm)	Impedance (Ωmax/100kHz 25±2°C)	Ripple current (mA r.m.s / 105°C 120Hz)	Dimensions: ΦD×L (mm)	Impedance (Ωmax/100kHz 25±2°C)	Ripple current (mA r.m.s / 105°C 120Hz)
Capacity (μF)												
12				8×9	12.50	150						
15	6.3×11	0.80	267	6.3×12	12.50	140	8×11.5	4.90	256	8×11.5	4.90	270
15	8×9	0.80	267	8×9	12.50	150	10×9	4.90	280	10×9	4.90	280
18	8×9	0.80	267	8×11.5	9.70	160	8×14	3.58	280	8×14	3.58	280
18				10×9	12.50	160	10×12.5	3.58	320	10×12.5	3.58	320
22	8×9	0.80	290	8×11.5	7.90	160	8×16	3.58	320	8×16	3.58	320
22				10×9	7.90	250	10×12.5	3.58	320	10×12.5	3.58	320
27	8×11.5	0.63	420	8×14	7.90	250						
27				10×12.5	7.90	250						
33	8×11.5	0.49	450	8×16	5.90	350	8×23	1.78	603	8×23	1.78	603
33	10×9	0.49	450	10×12.5	5.90	360	10×16	1.78	708	10×16	1.78	708
39	8×14	0.38	565	8×20	5.55	580						
39	10×12.5	0.38	565	10×14	5.55	635						
47	8×16	0.28	585	8×23	5.55	635	10×20	1.46	745	10×20	1.46	850
47	10×12.5	0.28	624	10×16	5.55	680	12.5×16	1.46	960	12.5×16	1.46	960
56	8×20	0.25	624	10×16	5.55	850	10×23	1.46	960	10×23	1.46	960
56	10×14	0.25	624	12.5×14	5.55	850	12.5×16	1.46	960	12.5×16	1.46	960
68	8×23	0.21	735	10×20	5.55	850	12.5×20	1.35	1270	12.5×20	1.35	1270
68	10×16	0.21	750	12.5×14	5.55	850	16×16	1.35	1270	16×16	1.35	1270
82	10×16	0.19	780	10×20	4.36	1020	12.5×20	1.35	1270	12.5×20	1.35	1270
82	12.5×14	0.19	900	12.5×16	4.36	1155	16×16	1.35	1270	16×16	1.35	1270
100	10×20	0.14	1040	12.5×16	4.36	1155	12.5×20	1.35	1360	12.5×25	1.32	1360
100	12.5×16	0.14	1040				16×16	1.35	1270	16×20	1.32	1410
120	10×23	0.12	1170	12.5×20	3.41	1390	12.5×25	1.25	1360	16×20	1.25	1500
120	12.5×16	0.12	1240	16×16	3.01	1420	16×20	1.32	1660			
150	12.5×20	0.0930	1368	12.5×25	3.01	1520	16×20	1.20	1850	16×25	1.25	1800
150				16×20	2.31	1850				18×20	1.25	1920
180	12.5×25	0.0660	1530	12.5×30	2.31	1850	16×25	0.95	2020	16×31.5	0.95	2250
180				16×20	2.31	1850	18×20	0.95	2020	18×25	0.95	2250
220	16×20	0.0660	1620	16×25	1.88	2400	18×25	0.91	2380	18×31.5	0.91	2625
220				18×20	1.88	2320						
270	12.5×30	0.0560	1750	16×31.5	1.80	2715						
270	16×20	0.0640	1750	18×25	0.98	2660						
330	16×25	0.0470	2140	18×25	0.98	2660						
330	18×20	0.0480	2140									
390	16×31.5	0.0400	2210	18×31.5	0.91	2715						
390	18×25	0.0400	2210									
470	16×31.5	0.0400	2270									
470	18×25	0.0400	2270									
560	16×35.5	0.0320	2600									
560	18×31.5	0.0320	2600									
680	18×35.5	0.0300	2860									



## ■ List of Standard Products

Voltage (V)	350			400			450			500		
project	Dimensions: ΦD×L (mm)	Impedance (Ωmax/100kHz 25±2°C)	Ripple current (mA r.m.s / 105°C 120Hz)	Dimensions: ΦD×L (mm)	Impedance (Ωmax/100kHz 25±2°C)	Ripple current (mA r.m.s / 105°C 120Hz)	Dimensions: ΦD×L (mm)	Impedance (Ωmax/100kHz 25±2°C)	Ripple current (mA r.m.s / 105°C 120Hz)	Dimensions: ΦD×L (mm)	Impedance (Ωmax/100kHz 25±2°C)	Ripple current (mA r.m.s / 105°C 120Hz)
Capacity (μF)												
1.0	5×9	55.00	73	5×9	55.00	73	5×9	55.00	73	6.3×9	52.00	45
1.2	5×9	36.00	90	5×9	36.00	76	5×9	52.00	78	6.3×9	52.00	45
1.5	5×9	36.00	90	5×9	36.00	76	5×11	52.00	81	6.3×9	52.00	45
1.5							6.3×9	52.00	90			
1.8	5×9	36.00	95	5×9	36.00	87	6.3×9	52.00	95	8×9	45.00	80
2.2	5×11	36.00	104	6.3×9	29.00	105	6.3×9	42.00	100	8×9	45.00	80
2.2	6.3×9	36.00	125									
2.7	6.3×9	26.00	125	6.3×9	26.00	125	6.3×9	42.00	100	8×11.5	18.50	85
3.3	6.3×9	23.00	131	6.3×9	25.00	131	6.3×12	25.00	120	8×11.5	18.50	85
3.3							8×9	25.00	120			
3.9	6.3×11	17.00	131	6.3×11	25.00	140	8×9	25.00	135	8×14	13.00	85
3.9	8×9	17.00	131	8×9	23.50	140						
4.7	6.3×11	17.00	140	6.3×12	23.50	140	8×11.5	18.50	135	8×16	13.00	130
4.7	8×9	17.00	140	8×9	23.50	140	10×9	18.50	135			
5.6	8×9	17.00	140	8×11.5	15.00	200	8×14	15.00	140	10×14	13.00	130
5.6				10×9	15.00	220	10×9	13.50	140			
6.8	8×11.5	15.00	200	8×11.5	15.00	210	8×16	8.05	220	10×14	13.00	130
6.8	10×9	17.00	210	10×9	15.00	250	10×12.5	12.00	200			
8.2	8×14	11.25	220	8×14	11.00	250	8×16	8.05	220	10×14	11.00	240
8.2	10×9	15.00	250	10×9	11.00	270	10×12.5	12.00	200			
10	8×14	8.05	250	8×16	8.05	270	8×20	8.05	260	8×23	11.00	240
10	10×12.5	11.00	270	10×12.5	11.00	270	10×14	8.05	350	10×16	10.00	260
12	8×20	9.00	360	10×14	9.00	340	10×16	7.90	370	12.5×14	9.50	265
15	8×20	6.50	360	10×14	8.50	340	10×16	7.70	370	12.5×16	8.00	270
15	10×14	6.50	460				12.5×14	7.70	370			
18	10×16	6.50	480	10×16	6.50	360	12.5×16	6.70	410	12.5×16	7.00	470
18	12.5×14	6.50	585	12.5×14	6.50	360						
22	10×20	6.50	585	10×20	6.50	570	12.5×16	6.70	450	12.5×20	7.00	470
22	12.5×14	6.50	585	12.5×16	6.50	570						

# LKM

## ■ List of Standard Products

Voltage (V)	350			400			450			500		
project Capacity (μF)	Dimensions: ΦD×L (mm)	Impedance (Ωmax/100kHz 25±2°C)	Ripple current (mA r.m.s / 105°C 120Hz)	Dimensions: ΦD×L (mm)	Impedance (Ωmax/100kHz 25±2°C)	Ripple current (mA r.m.s / 105°C 120Hz)	Dimensions: ΦD×L (mm)	Impedance (Ωmax/100kHz 25±2°C)	Ripple current (mA r.m.s / 105°C 120Hz)	Dimensions: ΦD×L (mm)	Impedance (Ωmax/100kHz 25±2°C)	Ripple current (mA r.m.s / 105°C 120Hz)
33	12.5×16	6.50	960	12.5×20	3.25	850	12.5×20	3.05	710	12.5×25	5.50	700
33				16×16	3.25	900	16×16	3.05	740	16×20	3.50	700
47	12.5×20	2.25	1115	12.5×25	2.25	1100	12.5×30	1.60	1215	16×25	2.50	720
47	16×16	2.25	1060	16×20	2.25	1155	16×20	1.60	1215			
56	12.5×25	2.25	1115	12.5×25	2.25	1155	16×25	1.60	1215	16×31.5	2.30	840
56	16×20	2.25	1155	16×20	2.25	1400	18×20	1.60	1215	18×25	2.30	840
68	12.5×30	2.25	1115	16×25	1.60	1460	16×31.5	1.60	1215	18×25	2.30	840
68	16×20	2.25	1400	18×20	1.60	1530	18×25	1.60	1300			
82	16×25	1.60	1550	16×31.5	1.60	1740	16×35.5	1.35	1675	18×31.5	1.80	1100
82	18×20	1.60	1530	18×25	1.60	1740	18×25	1.45	1700			
100	16×25	1.60	2230	18×25	1.60	1740	18×31.5	1.35	1800	18×35.5	1.50	1150
120	18×25	1.60	2305	18×31.5	1.50	2305	18×35.5	1.25	1930	18×40	1.40	1200
150	18×31.5	1.50	2720	18×35.5	1.50	3330	18×40	1.15	2350			

## LKE NEW

◆ High current withstand, impact resistant, high frequency, low impedance, specifically designed for motor frequency converters

◆ 10,000 hours of operation at 105°C

◆ Compliant with AEC-Q200 RoHS directive



### ■ Main technical parameters

project	characteristic																																				
Operating Temperature Range	$\cong 120V - 55\sim+105^{\circ}C ; 160\sim 250V - 40\sim+105^{\circ}C$																																				
Nominal Voltage Range	10~250V																																				
Capacity Tolerance	$\pm 20\%$ (25 $\pm 2^{\circ}C$ 120Hz)																																				
Leakage Current ( $\mu A$ )	10~120WV $I \cong 0.01CV$ or $3 \mu A$ (whichever is greater) C: Nominal capacitance ( $\mu F$ ) V: Rated voltage (V) Readings taken after 2 minutes 160~250WV $I \cong 0.02CV + 10(\mu A)$ C: Nominal capacitance ( $\mu F$ ) V: Rated voltage (V) Readings taken over 2 minutes																																				
Loss Tangent (25 $\pm 2^{\circ} C$ 120Hz)	<table border="1"> <tr> <td>Rated voltage (V)</td> <td>10</td> <td>16</td> <td>25</td> <td>35</td> <td>50</td> <td>63</td> <td>80</td> <td>100</td> </tr> <tr> <td>tg <math>\delta</math></td> <td>0.19</td> <td>0.16</td> <td>0.14</td> <td>0.12</td> <td>0.10</td> <td>0.09</td> <td>0.09</td> <td>0.09</td> </tr> <tr> <td>Rated voltage (V)</td> <td>120</td> <td>160</td> <td>200</td> <td>250</td> <td></td> <td></td> <td></td> <td></td> </tr> <tr> <td>tg <math>\delta</math></td> <td>0.09</td> <td>0.09</td> <td>0.08</td> <td>0.08</td> <td></td> <td></td> <td></td> <td></td> </tr> </table> <p>For nominal capacities exceeding 1000 <math>\mu F</math>, the loss tangent increases by 0.02 for every additional 1000 <math>\mu F</math>.</p>	Rated voltage (V)	10	16	25	35	50	63	80	100	tg $\delta$	0.19	0.16	0.14	0.12	0.10	0.09	0.09	0.09	Rated voltage (V)	120	160	200	250					tg $\delta$	0.09	0.09	0.08	0.08				
Rated voltage (V)	10	16	25	35	50	63	80	100																													
tg $\delta$	0.19	0.16	0.14	0.12	0.10	0.09	0.09	0.09																													
Rated voltage (V)	120	160	200	250																																	
tg $\delta$	0.09	0.09	0.08	0.08																																	
Temperature Characteristics (120Hz)	<table border="1"> <tr> <td>Rated voltage (V)</td> <td>10</td> <td>16</td> <td>25</td> <td>35</td> <td>50</td> <td>63</td> <td>80</td> <td>100</td> </tr> <tr> <td>Impedance ratio <math>Z(-40^{\circ}C)/Z(20^{\circ}C)</math></td> <td>6</td> <td>4</td> <td>3</td> <td>3</td> <td>3</td> <td>3</td> <td>3</td> <td>3</td> </tr> <tr> <td>Rated voltage (V)</td> <td>120</td> <td>160</td> <td>200</td> <td>250</td> <td></td> <td></td> <td></td> <td></td> </tr> <tr> <td>Impedance ratio <math>Z(-40^{\circ}C)/Z(20^{\circ}C)</math></td> <td>5</td> <td>5</td> <td>5</td> <td>5</td> <td></td> <td></td> <td></td> <td></td> </tr> </table>	Rated voltage (V)	10	16	25	35	50	63	80	100	Impedance ratio $Z(-40^{\circ}C)/Z(20^{\circ}C)$	6	4	3	3	3	3	3	3	Rated voltage (V)	120	160	200	250					Impedance ratio $Z(-40^{\circ}C)/Z(20^{\circ}C)$	5	5	5	5				
Rated voltage (V)	10	16	25	35	50	63	80	100																													
Impedance ratio $Z(-40^{\circ}C)/Z(20^{\circ}C)$	6	4	3	3	3	3	3	3																													
Rated voltage (V)	120	160	200	250																																	
Impedance ratio $Z(-40^{\circ}C)/Z(20^{\circ}C)$	5	5	5	5																																	
Durability	<p>In a 105°C oven, apply the rated voltage containing the rated ripple current for a specified time, then place at room temperature for 16 hours before testing. The test temperature is 25<math>\pm 2^{\circ}C</math>. The capacitor's performance should meet the following requirements.</p> <table border="1"> <tr> <td>Capacity change rate</td> <td>Within <math>\pm 20\%</math> of the initial value</td> </tr> <tr> <td>Loss tangent</td> <td>Below 200% of the specified value</td> </tr> <tr> <td>Leakage current</td> <td>Below the specified value</td> </tr> <tr> <td>Load life</td> <td><math>\cong \Phi 8</math> 10000小时</td> </tr> </table>	Capacity change rate	Within $\pm 20\%$ of the initial value	Loss tangent	Below 200% of the specified value	Leakage current	Below the specified value	Load life	$\cong \Phi 8$ 10000小时																												
Capacity change rate	Within $\pm 20\%$ of the initial value																																				
Loss tangent	Below 200% of the specified value																																				
Leakage current	Below the specified value																																				
Load life	$\cong \Phi 8$ 10000小时																																				
High Temperature Storage	<p>After being stored at 105°C for 1000 hours and then placed at room temperature for 16 hours for testing at a test temperature of 25<math>\pm 2^{\circ}C</math>, the capacitor performance should meet the following requirements.</p> <table border="1"> <tr> <td>Capacity change rate</td> <td>Within <math>\pm 20\%</math> of the initial value</td> </tr> <tr> <td>Loss tangent</td> <td>Below 200% of the specified value</td> </tr> <tr> <td>Leakage current</td> <td>Below 200% of the specified value</td> </tr> </table>	Capacity change rate	Within $\pm 20\%$ of the initial value	Loss tangent	Below 200% of the specified value	Leakage current	Below 200% of the specified value																														
Capacity change rate	Within $\pm 20\%$ of the initial value																																				
Loss tangent	Below 200% of the specified value																																				
Leakage current	Below 200% of the specified value																																				

### ■ Product dimension drawing (unit: mm)

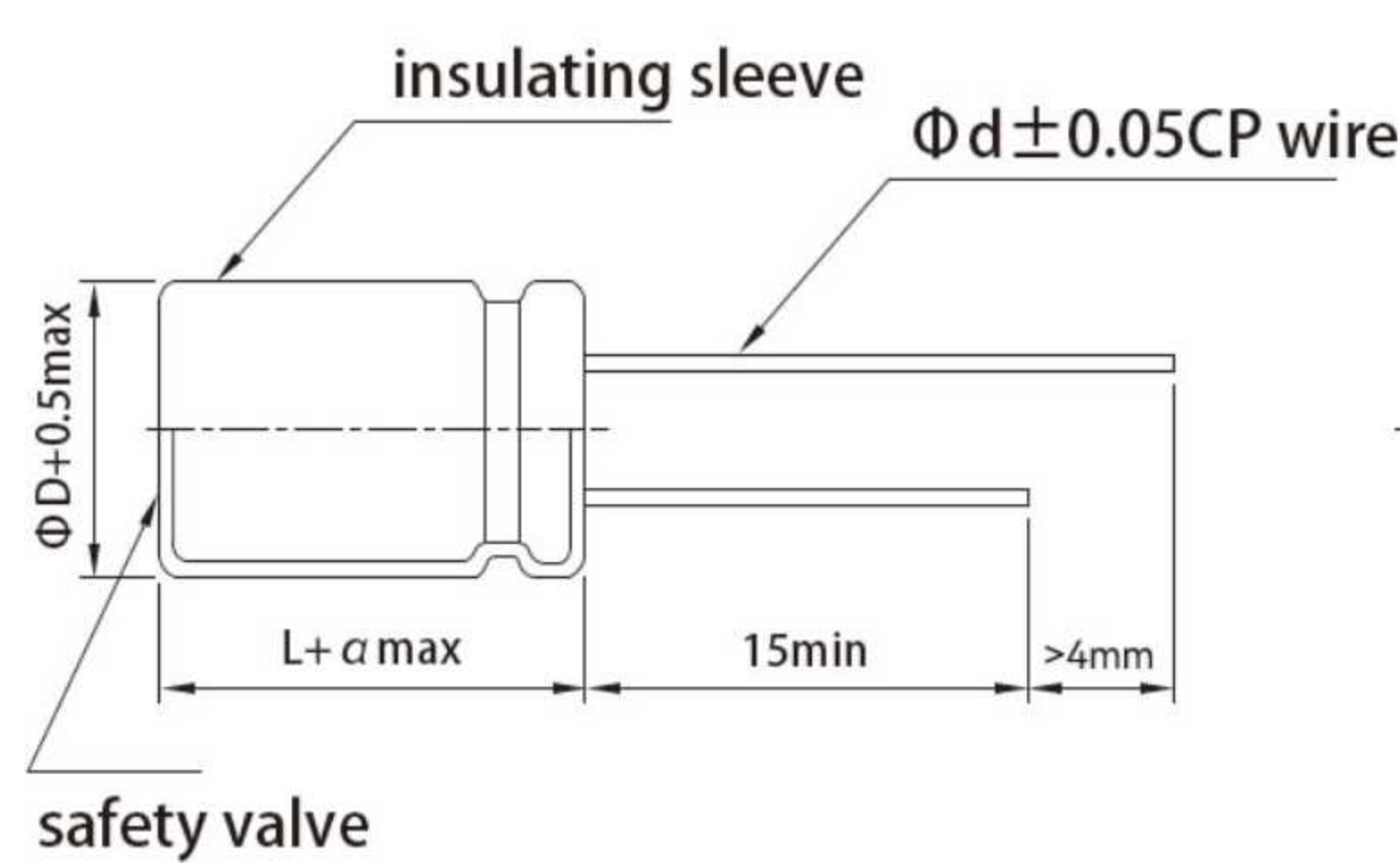

L=9	$\alpha=1.0$
$L \leq 16$	$\alpha=1.5$
$L > 16$	$\alpha=2.0$

10	12.5~13	12.5~13(h $\geq 30$ )	14.5
0.6	0.7	0.6	0.8
5.0	5.0	5.0	7.5

Note: Products  $\geq \Phi 6.3$  have a safety valve.

### ■ Ripple current compensation coefficient

#### Frequency correction factor

Frequency (Hz)	50	120	1K	10K~50K	100K
Correction Factor	0.40	0.50	0.80	0.90	1.00

#### Temperature correction factor

Frequency (Hz)	50°C	70°C	85°C	105°C
Correction Factor	2.1	1.8	1.4	1.0

## LKE

### List of Standard Products

Voltage (V)	10			16			25			35		
project	Dimensions: ΦD×L (mm)	Impedance (Ωmax/100kHz 25±2°C)	Ripple current (mA r.m.s / 105°C 120Hz)	Dimensions: ΦD×L (mm)	Impedance (Ωmax/100kHz 25±2°C)	Ripple current (mA r.m.s / 105°C 120Hz)	Dimensions: ΦD×L (mm)	Impedance (Ωmax/100kHz 25±2°C)	Ripple current (mA r.m.s / 105°C 120Hz)	Dimensions: ΦD×L (mm)	Impedance (Ωmax/100kHz 25±2°C)	Ripple current (mA r.m.s / 105°C 120Hz)
Capacity (μF)												
470										10×16	0.115	1000
560										10×20	0.0280	2250
560										13×16	0.0350	2330
680							10×16	0.0308	1850	10×25	0.0198	2330
1000				10×16	0.170	1000	10×20	0.140	1155	13×20	0.040	1500
1000							13×16	0.0350	2330			
1200				10×20	0.0280	1960				10×27	0.03	2220
1500	10×16	0.0308	1850	10×25	0.0280	2250	10×25	0.0280	2480	13×25	0.0165	2900
1500				13×16	0.0350	2330	13×16	0.0280	2480			
1500							13×20	0.0280	2480			
1800	10×20	0.0280	1960				10×27	0.03	2580	12.5×27	0.035	2800
1800							13×25	0.0165	2900	14.5×16	0.0143	3630
2200	10×25	0.0198	2250	13×20	0.104	1500	13×25	0.0143	3450	14.5×20	0.016	3150
2200	13×16	0.076	1500				14.5×16	0.27	2620			
2700							12.5×27	0.026	3050	13×27	0.025	3020
3300				10×27	0.0312	2800	13×27	0.025	3150			
3300	13×20	0.200	1780	13×25	0.081	2400	14.5×20	0.25	3180	14.5×25	0.015	3400
3900				14.5×16	0.0165	3250				14.5×27	0.014	3520
4700	10×27	0.035	2500	12.5×27	0.0285	3050	14.5×27	0.022	3460			
4700	13×25	0.0143	3450	14.5×20	0.255	3110	14.5×25	0.23	3350			
4700	14.5×16	0.0165	3450									
5600	12.5×27	0.027	2680									
6800	13×27	0.016	3110	13×27	0.0255	3280						
6800	14.5×20	0.018	2780	14.5×25	0.246	3270						
8200	14.5×25	0.016	3160									
10000	14.5×27	0.015	3280	14.5×27	0.0238	3450						

Voltage (V)	50			63			80			100		
project	Dimensions: ΦD×L (mm)	Impedance (Ωmax/100kHz 25±2°C)	Ripple current (mA r.m.s / 105°C 120Hz)	Dimensions: ΦD×L (mm)	Impedance (Ωmax/100kHz 25±2°C)	Ripple current (mA r.m.s / 105°C 120Hz)	Dimensions: ΦD×L (mm)	Impedance (Ωmax/100kHz 25±2°C)	Ripple current (mA r.m.s / 105°C 120Hz)	Dimensions: ΦD×L (mm)	Impedance (Ωmax/100kHz 25±2°C)	Ripple current (mA r.m.s / 105°C 120Hz)
Capacity (μF)												
100							10×16	1.00	550	10×16	1.00	560
120										10×20	0.8	650
150				10×16	0.2	998	13×16	0.14	975	13×16	0.50	700
150										10×25	0.2	1170
220	10×16	0.0460	1370	10×20	0.50	860	10×20	1.00	580	13×25	0.0660	1620

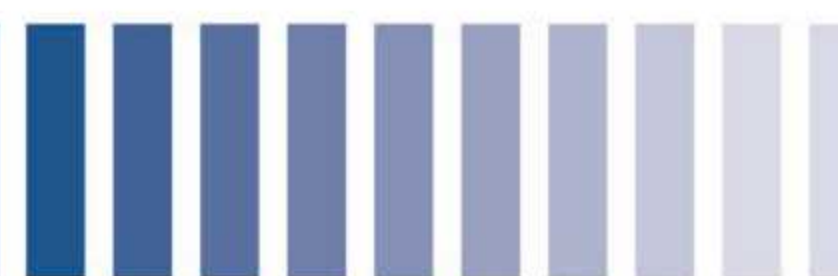

## LKE

### List of Standard Products

Voltage (V)	50			63			80			100		
project Capacity (μF)	Dimensions: ΦD×L (mm)	Impedance (Ωmax/100kHz 25±2°C)	Ripple current (mA r.m.s / 105°C 120Hz)	Dimensions: ΦD×L (mm)	Impedance (Ωmax/100kHz 25±2°C)	Ripple current (mA r.m.s / 105°C 120Hz)	Dimensions: ΦD×L (mm)	Impedance (Ωmax/100kHz 25±2°C)	Ripple current (mA r.m.s / 105°C 120Hz)	Dimensions: ΦD×L (mm)	Impedance (Ωmax/100kHz 25±2°C)	Ripple current (mA r.m.s / 105°C 120Hz)
270				13×16	0.0804	1250				10×27	0.072	1440
330	10×20	0.03	1580	10×25	0.0760	1410	13×20	0.45	890	13×25	0.0660	1620
330	13×16	0.8	980	13×20	0.45	1050				14.5×16	0.057	1500
390							10×27	0.0675	1420	12.5×27	0.056	1760
390										14.5×20	0.0640	1750
470	10×25	0.031	1870	13×25	0.45	1570	13×25	0.45	1050	13×27	0.05	1950
470	13×20	0.50	1050				14.5×16	0.076	1460	14.5×25	0.0480	2210
560				10×27	0.06	1800	12.5×27	0.056	1850	14.5×25	0.0420	2270
680	13×25	0.0560	2410	14.5×16	0.056	1620	13×27	0.055	1920	14.5×27	0.036	2150
680							14.5×20	0.063	1720			
820	10×27	0.062	1950	12.5×27	0.048	2220	14.5×25	0.2	1990			
820	14.5×16	0.058	2480									
1000	12.5×27	0.058	2520	13×27	0.043	2480	14.5×27	0.048	2080			
1000				14.5×20	0.018	2180						
1200	13×27	0.052	2560									
1200	14.5×20	0.048	2580	14.5×25	0.2	2420						
1500	14.5×25	0.03	2680	14.5×27	0.039	2540						
2200	14.5×27	0.028	2780									

Voltage (V)	160			200			250		
project Capacity (μF)	Dimensions: ΦD×L (mm)	Impedance (Ωmax/100kHz 25±2°C)	Ripple current (mA r.m.s / 105°C 120Hz)	Dimensions: ΦD×L (mm)	Impedance (Ωmax/100kHz 25±2°C)	Ripple current (mA r.m.s / 105°C 120Hz)	Dimensions: ΦD×L (mm)	Impedance (Ωmax/100kHz 25±2°C)	Ripple current (mA r.m.s / 105°C 120Hz)
22				10×16	3.24	400	10×16	3.24	400
33				10×20	1.65	340	10×20	1.65	340
47	10×16	2.65	650	13×20	1.50	400	13×16	1.50	400
56	10×20	2.65	920				10×27	4.65	870
56							13×20	1.40	500
68	13×16	2.27	1280	13×25	1.25	1300	13×20	1.25	1300
82	10×25	2.65	920	14.5×16	1.18	1420			
82	13×20	2.27	1280						
100	10×27	4.80	1040	10×27	4.5	1050	12.5×27	3.6	1150
100				14.5×20	1.18	1420	14.5×20	3.35	1200
120	13×25	1.43	1550				13×27	3.35	1260
120	14.5×16	4.50	1050				14.5×25	3.05	1280
150	12.5×27	4.50	1600	12.5×27	3.9	1520			
150				14.5×25	2.85	1720			
180	13×27	4.20	1700	13×27	3.2	1620	14.5×27	2.6	1325
180	14.5×20	4.00	1520						
220	14.5×25	3.50	1880	14.5×27	2.7	1880			
270	14.5×27	3.10	2020						

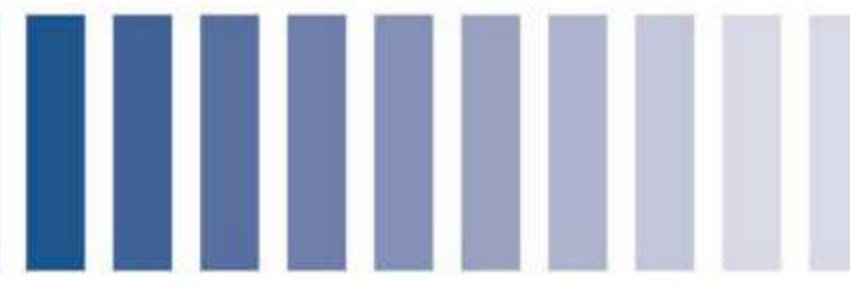

## LKZ

◆ Long lifespan, high frequency, low impedance, low temperature start-up; ideal for streetlights, outdoor lights, and high-end power supplies.

◆ 12,000~15,000 hours of operation at 105°C.

◆ Compliant with AEC-Q200 RoHS directive.



### Main technical parameters

project	characteristic																				
Operating Temperature Range	$\leq 120V - 55 \sim +105^{\circ}C$ ; $160 \sim 500V - 40 \sim +105^{\circ}C$ , $550 \sim 600V - 25 \sim +105^{\circ}C$																				
Nominal Voltage Range	10~600V																				
Capacity Tolerance	$\pm 20\%$ ( $25 \pm 2^{\circ}C$ 120Hz)																				
Leakage Current ( $\mu A$ )	10~120V, $I \leq 0.01CV$ or $3 \mu A$ (whichever is greater), C: Nominal capacitance ( $\mu F$ ), V: Rated voltage (V), Reading after 2 minutes.																				
	160~500V $I \leq 0.02CV + 10(\mu A)$ C: Nominal capacitance ( $\mu F$ ) V: Rated voltage (V) Readings taken over 2 minutes																				
	550~600V $I \leq 0.05CV + 10(\mu A)$ C: Nominal capacitance ( $\mu F$ ) V: Rated voltage (V) Readings taken over 2 minutes																				
Loss Tangent ( $25 \pm 2^{\circ}C$ 120Hz)	<table border="1"> <tr> <td>Rated voltage (V)</td> <td>10</td> <td>16</td> <td>25</td> <td>35</td> <td>50</td> <td>63</td> <td>80</td> <td>100</td> <td>120</td> </tr> <tr> <td>tg <math>\delta</math></td> <td>0.19</td> <td>0.16</td> <td>0.14</td> <td>0.12</td> <td>0.12</td> <td>0.12</td> <td>0.10</td> <td>0.10</td> <td>0.10</td> </tr> </table>	Rated voltage (V)	10	16	25	35	50	63	80	100	120	tg $\delta$	0.19	0.16	0.14	0.12	0.12	0.12	0.10	0.10	0.10
	Rated voltage (V)	10	16	25	35	50	63	80	100	120											
	tg $\delta$	0.19	0.16	0.14	0.12	0.12	0.12	0.10	0.10	0.10											
	<table border="1"> <tr> <td>Rated voltage (V)</td> <td>160</td> <td>200</td> <td>250</td> <td>350</td> <td>400</td> <td>450</td> <td>500</td> <td>550</td> <td>600</td> </tr> <tr> <td>tg <math>\delta</math></td> <td>0.12</td> <td>0.15</td> <td>0.15</td> <td>0.18</td> <td>0.20</td> <td>0.20</td> <td>0.24</td> <td>0.25</td> <td>0.30</td> </tr> </table>	Rated voltage (V)	160	200	250	350	400	450	500	550	600	tg $\delta$	0.12	0.15	0.15	0.18	0.20	0.20	0.24	0.25	0.30
Rated voltage (V)	160	200	250	350	400	450	500	550	600												
tg $\delta$	0.12	0.15	0.15	0.18	0.20	0.20	0.24	0.25	0.30												
For nominal capacities exceeding 1000 $\mu F$ , the loss tangent increases by 0.02 for every additional 1000 $\mu F$ .																					
Temperature Characteristics (120Hz)	<table border="1"> <tr> <td>Rated voltage (V)</td> <td>10</td> <td>16</td> <td>25</td> <td>35</td> <td>50</td> <td>63</td> <td>80</td> <td>100</td> <td>120</td> </tr> <tr> <td>Impedance ratio <math>Z(-40^{\circ}C)/Z(20^{\circ}C)</math></td> <td>6</td> <td>4</td> <td>3</td> <td>3</td> <td>3</td> <td>3</td> <td>3</td> <td>3</td> <td>5</td> </tr> </table>	Rated voltage (V)	10	16	25	35	50	63	80	100	120	Impedance ratio $Z(-40^{\circ}C)/Z(20^{\circ}C)$	6	4	3	3	3	3	3	3	5
	Rated voltage (V)	10	16	25	35	50	63	80	100	120											
	Impedance ratio $Z(-40^{\circ}C)/Z(20^{\circ}C)$	6	4	3	3	3	3	3	3	5											
	<table border="1"> <tr> <td>Rated voltage (V)</td> <td>160</td> <td>200</td> <td>250</td> <td>350</td> <td>400</td> <td>450</td> <td>500</td> <td>550</td> <td>600</td> </tr> <tr> <td>Impedance ratio <math>Z(-40^{\circ}C)/Z(20^{\circ}C)</math></td> <td>5</td> <td>5</td> <td>5</td> <td>7</td> <td>7</td> <td>7</td> <td>8</td> <td>16</td> <td>18</td> </tr> </table>	Rated voltage (V)	160	200	250	350	400	450	500	550	600	Impedance ratio $Z(-40^{\circ}C)/Z(20^{\circ}C)$	5	5	5	7	7	7	8	16	18
Rated voltage (V)	160	200	250	350	400	450	500	550	600												
Impedance ratio $Z(-40^{\circ}C)/Z(20^{\circ}C)$	5	5	5	7	7	7	8	16	18												
After being stored at 105°C for 1000 hours and then placed at room temperature for 16 hours for testing at a test temperature of $25 \pm 2^{\circ}C$ , the capacitor performance should meet the following requirements.																					
Durability	Capacity change rate	Within $\pm 20\%$ of the initial value																			
	Loss tangent	Below 200% of the specified value																			
	Leakage current	Below the specified value																			
	Load life	$\Phi 8 \sim \Phi 10$	12000h																		
$\geq \Phi 12.5$		15000h																			
High Temperature Storage	After being stored at 105°C for 1000 hours and then placed at room temperature for 16 hours for testing at a test temperature of $25 \pm 2^{\circ}C$ , the capacitor performance should meet the following requirements.																				
	Capacity change rate	Within $\pm 20\%$ of the initial value																			
	Loss tangent	Below 200% of the specified value																			
	Leakage current	Below 200% of the specified value																			

### Product dimension drawing (unit: mm)

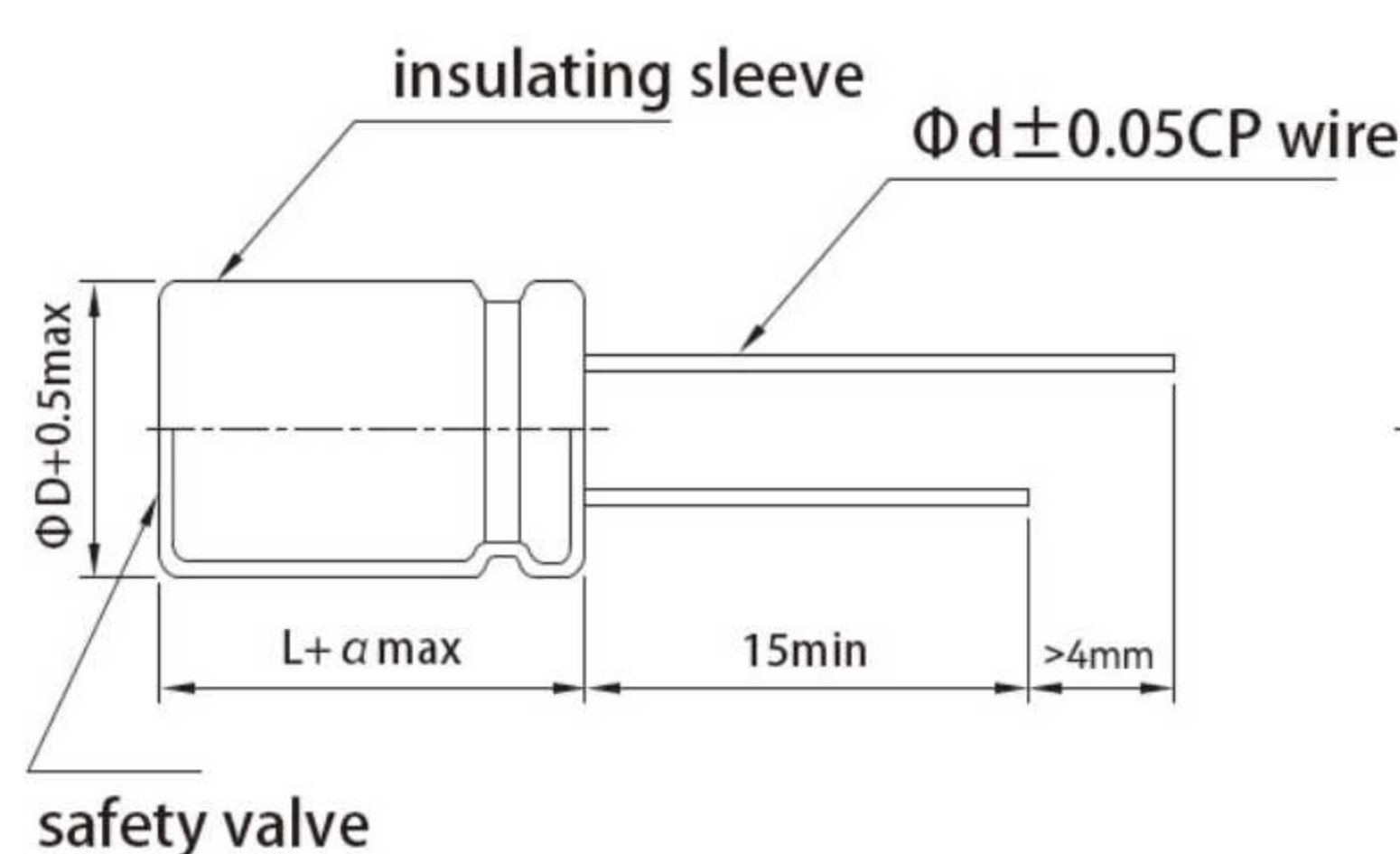

L=9	$\alpha=1.0$
$L \leq 16$	$\alpha=1.5$
$L > 16$	$\alpha=2.0$

D	8	10	12.5~13	12.5~13(h $\geq$ 30)	14.5	16	18	20	22	25
d	0.6	0.6	0.7	0.6	0.8	0.8	0.8	0.8	1.0	1.0
F	3.5	5.0	5.0	5.0	7.5	7.5	7.5	10	10	10

Note: Products  $\geq \Phi 6.3$  have a safety valve.

### Ripple current compensation coefficient

#### ① Frequency correction factor

Frequency (Hz)	50	120	1K	10K~50K	100K
Correction Factor	0.40	0.50	0.80	0.90	1.00

#### ② Temperature correction factor

Ambient temperature ( $^{\circ}C$ )	50°C	70°C	85°C	105°C
Correction factor	2.1	1.8	1.4	1.0



## LKZ

### List of Standard Products

Voltage (V)	10			16			25			35		
project	Dimensions: ΦD×L (mm)	Impedance (Ωmax/100kHz 25±2°C)	Ripple current (mA r.m.s / 105°C 120Hz)	Dimensions: ΦD×L (mm)	Impedance (Ωmax/100kHz 25±2°C)	Ripple current (mA r.m.s / 105°C 120Hz)	Dimensions: ΦD×L (mm)	Impedance (Ωmax/100kHz 25±2°C)	Ripple current (mA r.m.s / 105°C 120Hz)	Dimensions: ΦD×L (mm)	Impedance (Ωmax/100kHz 25±2°C)	Ripple current (mA r.m.s / 105°C 120Hz)
Capacity (μF)												
150										8×11.5	3.600	1008
150										10×9	3.500	1029
180										8×14	2.820	1008
180										10×9	2.820	1029
220							8×11.5	3.600	1008	8×16	2.500	1334
220							10×9	3.500	1029	10×12.5	2.500	1334
270							8×11.5	3.500	1008	8×16	1.9530	1334
270							10×9	3.500	1029	10×12.5	1.9530	1397
330							8×14	2.200	1008	10×12.5	1.9530	1397
390				8×11.5	3.600	1008	8×16	0.2800	1334	10×16	1.5258	1943
390				10×9	3.500	1029	10×12.5	0.2800	1334			
470				8×11.5	2.820	1008	10×12.5	0.2800	1397	10×16	1.1920	1943
470				10×9	2.820	1029						
560	8×11.5	0.2180	1008	8×16	0.2800	1334	8×20	0.2500	1607	10×20	0.1150	2363
560	10×9	0.2180	1029	10×12.5	0.2800	1397	10×16	0.2500	1943	12.5×16	0.1150	2447
680	8×11.5	0.2180	1008	8×16	0.2800	1334	10×16	0.2500	1943	10×23	0.1100	2447
680	10×9	0.2180	1029	10×12.5	0.2800	1397				12.5×16	0.1150	2447
820	8×14	0.1702	1229	8×20	0.2188	1607	10×20	0.1953	2363	12.5×20	0.0950	2604
820	10×12.5	0.1702	1334	10×16	0.2188	1943	12.5×16	0.1953	2447			
1000	8×16	0.1330	1334	8×20	0.1708	1607	10×23	0.1526	2447	12.5×20	0.0950	2604
1000	10×12.5	0.1330	1397	10×16	0.1708	1943	12.5×16	0.1526	2447			
1200	8×20	0.1039	1607	10×20	0.0730	2058	12.5×20	0.0800	2604	12.5×25	0.0810	3045
1200	10×14	0.1039	1848	12.5×16	0.0730	2447						
1500	8×20	0.0934	1607	10×20	0.0730	2058	12.5×20	0.0650	2604	12.5×30	0.0752	3623
1500	10×16	0.0934	1943	12.5×16	0.0730	2447				16×20	0.0452	3413
1800	10×20	0.0730	2058	10×23	0.0570	2363	12.5×25	0.0500	3045	12.5×35	0.0430	3749
1800	12.5×16	0.0730	2447	12.5×20	0.0570	2604				16×25	0.0430	3812
2200	10×20	0.0730	2058	12.5×20	0.0570	2604	12.5×30	0.0456	3623	16×25	0.0410	3812
2200	12.5×16	0.0570	2447				16×20	0.0456	3413			
2700	10×23	0.0446	2363	12.5×25	0.0400	3045	12.5×35	0.0412	3749	16×35.5	0.0400	4211
2700	12.5×20	0.0446	2604				16×25	0.0412	3812	18×31.5	0.0400	4389
3300	12.5×20	0.0446	2604	12.5×30	0.0380	3623	12.5×40	0.0380	4085	16×40	0.0280	4431
3300				16×20	0.0380	3413	16×25	0.0380	3812	18×35.5	0.0280	4431
3900	12.5×25	0.0400	3045	12.5×30	0.0380	3623	16×31.5	0.0340	4085	18×40	0.0218	4725
3900				16×20	0.0380	3413	18×25	0.0340	4085			
4700	12.5×30	0.0390	3623	12.5×35	0.0360	3749	16×35.5	0.0310	4211			
4700	16×20	0.0390	3623	16×25	0.0360	3812	18×31.5	0.0310	4389			
5600	16×25	0.0380	3749	16×31.5	0.0340	4085	18×35.5	0.0280	4431			
5600	18×20	0.0380	3749	18×25	0.0340	4085						
6800	16×31.5	0.0340	3812	16×35.5	0.0310	4211	18×40	0.0218	4725			
6800	18×25	0.0340	3812	18×31.5	0.0310	4389						



■ List of Standard Products

Voltage (V)	50			63			80			100		
project	Dimensions: ΦD×L (mm)	Impedance (Ωmax/100kHz 25±2°C)	Ripple current (mA r.m.s / 105°C 120Hz)	Dimensions: ΦD×L (mm)	Impedance (Ωmax/100kHz 25±2°C)	Ripple current (mA r.m.s / 105°C 120Hz)	Dimensions: ΦD×L (mm)	Impedance (Ωmax/100kHz 25±2°C)	Ripple current (mA r.m.s / 105°C 120Hz)	Dimensions: ΦD×L (mm)	Impedance (Ωmax/100kHz 25±2°C)	Ripple current (mA r.m.s / 105°C 120Hz)
Capacity (μF)												
15										8×11.5	2.70	485
15										10×9	2.70	525
18										8×11.5	2.70	485
18										10×9	2.70	525
22										8×11.5	2.70	485
22										10×9	2.70	525
27										8×16	2.00	614
27										10×12.5	2.00	655
33							8×11.5	2.60	485	8×16	2.00	614
33							10×9	2.60	525	10×12.5	2.00	655
39							8×11.5	2.09	485	8×16	1.56	614
39							10×9	2.09	525	10×12.5	1.56	655
47				8×11.5	2.6	546	8×11.5	1.50	485	10×12.5	1.56	655
47				10×9	2.6	562						
56				8×11.5	2.6	546	8×16	1.20	614	10×12.5	1.20	788
56				10×9	2.6	562	10×12.5	1.20	614			
68				8×11.5	2.09	546	8×16	1.20	614	8×20	1.00	809
68				10×9	2.09	562	10×12.5	1.20	655	10×16	1.00	819
82	8×11.5	2.60	777	8×16	1.50	758	10×12.5	1.20	655	10×16	1.00	819
82	10×9	2.60	699	10×12.5	1.50	683						
100	8×11.5	2.09	777	8×16	1.50	758	8×20	1.00	840	10×20	0.78	1092
100	10×9	2.09	699	10×12.5	1.50	758	10×16	1.00	819	12.5×16	0.78	1024
120	8×16	1.5000	1019	10×12.5	1.50	758	10×16	1.00	819	10×23	0.500	1229
120	10×12.5	1.5000	1034				8×20	1.00	819	12.5×20	0.500	1502
150	8×16	1.5000	1019	8×20	1.20	935	10×20	0.80	1092	12.5×20	0.500	1502
150	10×12.5	1.5000	1034	10×16	1.20	1048	12.5×16	0.80	1024			
180	8×20	1.3400	1281	10×16	1.20	1048	10×20	0.80	1092	12.5×25	0.4600	1701
180	10×16	1.3400	1439				12.5×16	0.80	1024			
220	8×20	1.3400	1281	10×20	0.9300	1260	10×23	0.60	1229	12.5×25	0.4600	1701
220	10×16	1.3400	1439	12.5×16	0.9300	1313	12.5×20	0.60	1502			
270	10×20	0.9300	1659	10×20	0.9300	1260	12.5×20	0.60	1502	12.5×30	0.4400	2048
270	12.5×16	0.9300	1840	12.5×16	0.8040	1313				16×20	0.4400	1838
330	10×20	0.9300	1659	10×23	0.7600	1481	12.5×25	0.5400	1701	12.5×35	0.4000	2247
330	12.5×16	0.8000	1840	12.5×20	0.5000	1649				16×25	0.4000	2321
390	10×23	0.7600	1964	12.5×20	0.5000	1649	12.5×30	0.4900	2048	12.5×40	0.3200	2457
390	12.5×20	0.5000	2153				16×20	0.4900	1838	16×25	0.3200	2321
470	12.5×20	0.5000	2153	12.5×25	0.4500	2090	12.5×35	0.4500	2247	16×31.5	0.1000	2520
470							16×25	0.4500	2321	18×25	0.1000	2384
560	12.5×25	0.3900	2531	12.5×30	0.4400	2531	12.5×40	0.4400	2457	16×35.5	0.0920	2730



■ List of Standard Products

Voltage (V)	50			63			80			100		
project Capacity (μF)	Dimensions: ΦD×L (mm)	Impedance (Ωmax/100kHz 25±2°C)	Ripple current (mA r.m.s / 105°C 120Hz)	Dimensions: ΦD×L (mm)	Impedance (Ωmax/100kHz 25±2°C)	Ripple current (mA r.m.s / 105°C 120Hz)	Dimensions: ΦD×L (mm)	Impedance (Ωmax/100kHz 25±2°C)	Ripple current (mA r.m.s / 105°C 120Hz)	Dimensions: ΦD×L (mm)	Impedance (Ωmax/100kHz 25±2°C)	Ripple current (mA r.m.s / 105°C 120Hz)
560				16×20	0.4400	2531	16×25	0.4400	2321	18×31.5	0.0920	2594
680	12.5×25	0.3050	2531	12.5×35	0.4300	2751	16×31.5	0.4300	2520	16×40	0.0840	3003
680				16×25	0.4300	2867	18×25	0.4300	2384	18×35.5	0.0840	3003
820	12.5×30	0.2380	3108	12.5×40	0.4200	3087	16×35.5	0.4200	2730	18×40	0.0660	3686
820	16×20	0.2380	2867	16×25	0.4200	2867	18×25	0.4200	2384			
1000	12.5×35	0.0500	3108	16×31.5	0.4100	3140	16×40	0.4100	3003			
1000	16×25	0.0500	3161	18×25	0.4100	2940	18×31.5	0.4100	2594			
1200	16×31.5	0.0390	3444	16×31.5	0.4100	3140	18×35.5	0.4000	3003			
1200	18×25	0.0390	3213	18×25	0.4100	2940						
1500	16×35.5	0.0350	3192	16×35.5	0.4000	3192	18×40	0.3900	3686			
1500	18×31.5	0.0350	3465	18×31.5	0.4000	3465						
1800	16×35.5	0.0350	3192	16×40	0.3900	3749						
1800	18×31.5	0.0350	3465	18×35.5	0.3900	3749						
2200	18×35.5	0.0318	3749	18×40	0.3800	4095						
2700	18×40	0.0290	4095									

Voltage (V)	120			160			200			250		
project Capacity (μF)	Dimensions: ΦD×L (mm)	Impedance (Ωmax/100kHz 25±2°C)	Ripple current (mA r.m.s / 105°C 120Hz)	Dimensions: ΦD×L (mm)	Impedance (Ωmax/100kHz 25±2°C)	Ripple current (mA r.m.s / 105°C 120Hz)	Dimensions: ΦD×L (mm)	Impedance (Ωmax/100kHz 25±2°C)	Ripple current (mA r.m.s / 105°C 120Hz)	Dimensions: ΦD×L (mm)	Impedance (Ωmax/100kHz 25±2°C)	Ripple current (mA r.m.s / 105°C 120Hz)
6.8										8×11.5	10.15	168
6.8										10×9	10.15	151
8.2							8×11.5	10.15	168	8×11.5	10.15	168
8.2							10×9	10.15	189	10×9	10.15	151
10							8×11.5	10.15	179	8×14	9.50	305
10							10×9	10.15	189	10×12.5	4.50	383
12				8×11.5	10.15	176	8×14	8.75	240	8×16	4.05	305
15	8×11.5	4.00	429	8×11.5	10.00	274	8×16	3.24	305	8×16	3.65	305
15	10×9	4.00	455	10×9	10.00	274	10×12.5	4.50	383	10×14	3.24	399
48	8×11.5	4.00	429	8×14	7.50	305	8×20	3.24	389	8×20	3.24	389
18	10×9	4.00	455	10×12.5	7.50	274	10×14	3.24	399	10×16	3.24	420
22	8×14	3.60	478	8×20	4.27	368	8×20	3.24	389	10×16	3.24	420
22	10×9	4.00	519	10×12.5	7.50	399	10×16	3.24	420			
27	8×16	3.00	543	8×20	2.65	368	10×20	2.53	466	10×20	2.53	466
27	10×12.5	3.00	579	10×12.5	2.65	399	12.5×14	2.53	665	12.5×16	2.53	665
33	8×16	3.00	543	10×16	2.65	683	10×20	1.65	683	10×20	1.65	683
33	10×12.5	3.00	579	12.5×14	2.65	798	12.5×14	1.65	798	12.5×16	1.65	798



■ List of Standard Products

Voltage (V)	120			160			200			250		
project	Dimensions: ΦD×L (mm)	Impedance (Ωmax/100kHz 25±2°C)	Ripple current (mA r.m.s / 105°C 120Hz)	Dimensions: ΦD×L (mm)	Impedance (Ωmax/100kHz 25±2°C)	Ripple current (mA r.m.s / 105°C 120Hz)	Dimensions: ΦD×L (mm)	Impedance (Ωmax/100kHz 25±2°C)	Ripple current (mA r.m.s / 105°C 120Hz)	Dimensions: ΦD×L (mm)	Impedance (Ωmax/100kHz 25±2°C)	Ripple current (mA r.m.s / 105°C 120Hz)
Capacity (μF)												
39	8×20	2.65	597	10×16	2.65	683	12.5×20	1.50	958	12.5×20	1.5	958
39	10×14	2.65	636	12.5×14	2.65	798						
47	10×14	2.65	636	10×20	2.65	788	12.5×20	1.50	1029	12.5×20	1.38	1029
47				12.5×14	2.65	798						
56	10×16	2.21	720	10×20	2.65	966	12.5×20	1.38	1029	12.5×20	1.38	1029
56	12.5×14	2.20	756	12.5×16	2.27	1239						
68	10×20	2.00	792	12.5×20	2.27	1344	12.5×25	1.25	1365	12.5×25	1.25	1365
68	12.5×14	2.20	792				16×20	1.25	1491	16×20	1.25	1491
82	12.5×16	2.00	880	12.5×20	2.27	1344	12.5×30	1.25	1460	12.5×30	1.15	1460
82							16×20	1.18	1491	16×20	1.18	1491
100	12.5×20	1.80	1161	12.5×20	2.27	1344	12.5×25	1.15	1460	16×25	1.18	2048
100										18×20	1.02	2048
120	12.5×20	1.80	1340	12.5×25	1.43	1628	16×20	1.18	2048	16×25	1.02	2048
120				16×20	1.25	1491				18×20	1.02	2090
150	12.5×25	1.60	1463	12.5×25	1.43	2058	16×25	1.18	2252	16×31.5	0.98	2132
150	16×20	1.60	1524				18×20	1.18	2252	18×25	0.98	2132
180	16×20	1.43	1731	16×20	1.43	1985	16×35.5	0.92	2415	18×25	0.80	2415
180							18×25	0.92	2415			
220	16×25	1.19	2078	16×25	1.14	2573	16×35.5	0.80	2415	18×31.5	0.74	2814
220	18×20	1.19	2078	18×20	1.14	2489	18×31.5	0.80	2415			
270	16×31.5	1.10	2490	16×31.5	1.14	2573	16×40	0.74	2656			
270	18×25	1.10	2490				18×31.5	0.74	2656			
330	16×31.5	1.10	2520	16×31.5	1.10	3360	16×40	0.74	2898			
330	18×25	1.10	2520	18×25	1.10	3360	18×31.5	0.74	2898			
390	16×35.5	1.00	2730	16×35.5	0.95	3623	16×45	0.62	3188			
390	18×31.5	1.00	2730	18×31.5	0.95	3623	18×35.5	0.62	3188			
470	18×35.5	0.90	3003	18×35.5	0.90	3819	18×40	0.56	3623			
560	18×40	0.84	3686	18×40	0.85	3919	18×45	0.44	3969			

## LKL(R)

- ◆ High temperature resistant, long lifespan, power supply specific product
- ◆ 2000~5000 hours at 130°C
- ◆ Compliant with AEC-Q200 RoHS directive



### Main technical parameters

project	characteristic																		
Operating Temperature Range	- 55~+135°C																		
Nominal Voltage Range	10~100V																		
Capacity Tolerance	±20% (25±2°C 120Hz)																		
Leakage Current (μA)	10~100WV I <sub>l</sub> ≅ 0.01CV or 3 μA (whichever is greater) C: Nominal capacitance (μF) V: Rated voltage (V) Readings taken after 2 minutes																		
Loss Tangent (25 ± 2° C 120Hz)	<table border="1"> <tr> <td>Rated voltage (V)</td> <td>10</td> <td>16</td> <td>25</td> <td>35</td> <td>50</td> <td>63</td> <td>80</td> <td>100</td> </tr> <tr> <td>tg δ</td> <td>0.20</td> <td>0.16</td> <td>0.14</td> <td>0.12</td> <td>0.10</td> <td>0.09</td> <td>0.09</td> <td>0.08</td> </tr> </table>	Rated voltage (V)	10	16	25	35	50	63	80	100	tg δ	0.20	0.16	0.14	0.12	0.10	0.09	0.09	0.08
	Rated voltage (V)	10	16	25	35	50	63	80	100										
tg δ	0.20	0.16	0.14	0.12	0.10	0.09	0.09	0.08											
For nominal capacities exceeding 1000 μF, the loss tangent increases by 0.02 for every additional 1000 μF.																			
Temperature Characteristics (120Hz)	<table border="1"> <tr> <td>Rated voltage (V)</td> <td>10</td> <td>16</td> <td>25</td> <td>35</td> <td>50</td> <td>63</td> <td>80</td> <td>100</td> </tr> <tr> <td>Impedance ratio Z(-40°C)/Z(20°C)</td> <td>12</td> <td>8</td> <td>6</td> <td>4</td> <td>4</td> <td>4</td> <td>4</td> <td>4</td> </tr> </table>	Rated voltage (V)	10	16	25	35	50	63	80	100	Impedance ratio Z(-40°C)/Z(20°C)	12	8	6	4	4	4	4	4
	Rated voltage (V)	10	16	25	35	50	63	80	100										
Impedance ratio Z(-40°C)/Z(20°C)	12	8	6	4	4	4	4	4											
After being stored at 135°C for 1000 hours and then placed at room temperature for 16 hours for testing at a test temperature of 25±2°C, the capacitor performance should meet the following requirements.																			
Durability	Capacity change rate	Within ±30% of the initial value																	
	Loss tangent	Below 300% of the specified value																	
	Leakage current	Below the specified value																	
	Load life	3000h																	
High temperature storage	After being stored at 105°C for 1000 hours and then placed at room temperature for 16 hours for testing at a test temperature of 25±2°C, the capacitor performance should meet the following requirements.																		
	Capacity change rate	Within ±30% of the initial value																	
	Loss tangent	Below 300% of the specified value																	
	Leakage current	Below 200% of the specified value																	

### Product dimension drawing (unit: mm)

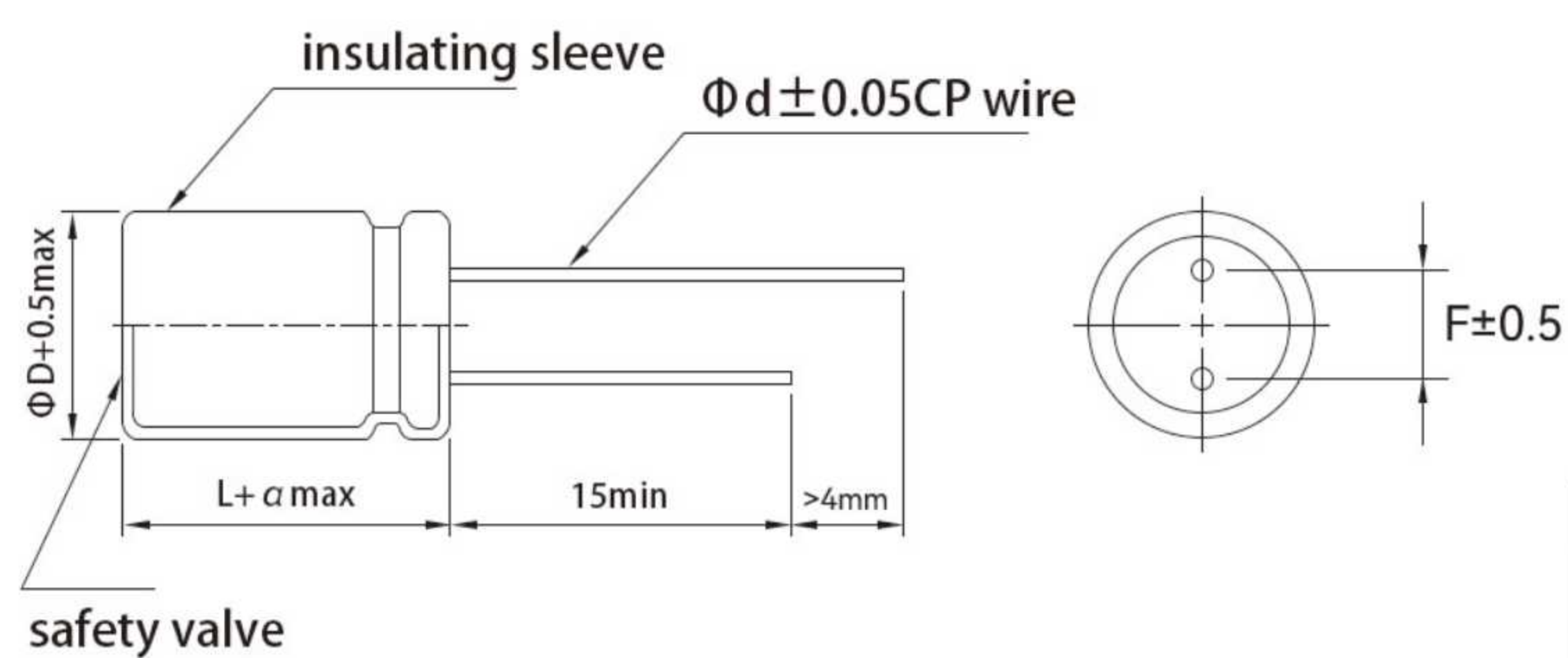

L=9	α=1.0
L≤16	α=1.5
L > 16	α=2.0

D	6.3	8	10	12.5~13	12.5~13(h≥30)	14.5	16	18
d	0.5(0.45)	0.6(0.5)	0.6	0.7	0.6	0.8	0.8	0.8
F	2.5	3.5	5.0	5.0	5.0	7.5	7.5	7.5

Note: Products ≥ Φ6.3 have a safety valve.

### Frequency correction factor

Frequency (Hz)	50	120	1K	≥10K
coefficient	0.35	0.50	0.83	1.00

# LKL(R)

## List of Standard Products

Voltage (V)	10			16			25			35		
project	Dimensions: ΦD×L (mm)	Impedance (Ωmax/100kHz 25±2°C)	Ripple current (mA r.m.s / 105°C 120Hz)	Dimensions: ΦD×L (mm)	Impedance (Ωmax/100kHz 25±2°C)	Ripple current (mA r.m.s / 105°C 120Hz)	Dimensions: ΦD×L (mm)	Impedance (Ωmax/100kHz 25±2°C)	Ripple current (mA r.m.s / 105°C 120Hz)	Dimensions: ΦD×L (mm)	Impedance (Ωmax/100kHz 25±2°C)	Ripple current (mA r.m.s / 105°C 120Hz)
Capacity (μF)												
100				6.3*9	4.95	240	6.3*9	4.95	240	8*9	4.95	324
150							8*9	4.95	324	8*11.5	3.96	380
150										10*9	3.85	324
220				8*9	4.95	324	8*11.5	3.96	380	8*11.5	2.75	650
330	8*9	3.85	324	8*9	3.96	380	8*14	0.31	650	10*12.5	0.28	850
330							10*12.5	0.31	650			
470	8*9	0.165	620	8*11.5	0.308	650	10*12.5	0.28	850	10*16	0.1265	1000
560												
680												
750												
820										16*16	0.060	1200
910												
910												
1000	10*12.5	0.1078	1000	10*16	0.187	1000	10*20	0.154	1150	12.5*20	0.044	1500
1000										16*16	0.057	1200
1100												
1200							16*16	0.045	1200	18*16	0.053	1400
1300												
1300												
1300												
1500							16*16	0.043	1200	16*20	0.045	1500
1500										18*16	0.040	1400
1600												
1600												
1800							16*16	0.040	1200	18*20	0.038	1580
2000										16*20	0.038	1500
2200	12.5*16	0.084	1500	12.5*20	0.114	1500	18*16	0.041	1400	12.5*30	0.036	2760
2200										18*20	0.038	1600
2300												
2400												
2700							16*20	0.040	1700	18*20	0.038	1700
2700										12.5*35	0.031	2890
3000										16*25	0.032	2740
3300	12.5*20	0.079	1780	12.5*25	0.0891	2400	16*20	0.038	1800	12.5*40	0.029	3160
3600							12.5*30	0.034	2760	16*30	0.028	3020
3900										18*25	0.031	2760
4300							18*20	0.041	1750	16*35	0.025	3150
4700							12.5*35	0.032	2850	18*30	0.028	3200
4700							16*25	0.034	2650			
5100							12.5*40	0.030	3200			
5600							16*30	0.031	2900	16*40	0.024	3540
6200							18*25	0.033	2720	18*35	0.024	3400
7500							16*35	0.030	3450	18*40	0.023	3750
7500							18*30	0.034	3280			
9100							16*40	0.023	3630			
10000							18*35	0.023	3600			
12000							18*40	0.022	3890			



# LKL(R)

## List of Standard Products

Voltage (V)	50			63			80			100		
project	Dimensions: ΦD×L (mm)	Impedance (Ωmax/100kHz 25±2°C)	Ripple current (mA r.m.s / 105°C 120Hz)	Dimensions: ΦD×L (mm)	Impedance (Ωmax/100kHz 25±2°C)	Ripple current (mA r.m.s / 105°C 120Hz)	Dimensions: ΦD×L (mm)	Impedance (Ωmax/100kHz 25±2°C)	Ripple current (mA r.m.s / 105°C 120Hz)	Dimensions: ΦD×L (mm)	Impedance (Ωmax/100kHz 25±2°C)	Ripple current (mA r.m.s / 105°C 120Hz)
Capacity (μF)												
10										6.3×9	4.07	180
15										6.3×11	2.97	210
15							6.3×9	4.07	180	8×9	4.07	180
22							6.3×11	2.86	210	8×11.5	2.97	230
22				6.3×9	2.86	180	8×9	4.07	180	10×9	4.07	198
33	6.3×9	2.86	245	6.3×11	2.86	265	6.3×11	2.86	230	8×11.5	2.20	280
33				8×9	2.20	280	8×9	2.20	198	10×9	2.20	280
47	6.3×11	2.86	320	8×9	2.20	420	8×11.5	2.20	280	10×12.5	1.10	350
47	8×9	2.86	330				10×9	2.20	280			
56							10×9	2.20	280			
100	8×11.5	1.65	500	8×16	1.32	590	10×16	1.10	550	12.5×16	0.55	700
100	10×9	1.65	550	10×12.5	1.32	590						
220	10×16	1.10	940	10×20	0.55	860	12.5×20	0.50	890	12.5×25	0.44	1155
330	12.5×16	0.88	980	12.5×20	0.495	1050	12.5×25	0.495	1050			
470	12.5×20	0.55	1050	12.5×25	0.495	1570						
470	16*16	0.080	1000									
560	16*16	0.078	1000									
680	18*16	0.078	1200	16*20	0.058	1700						
750				12.5*30	0.050	2480						
820	18*16	0.070	1200									
910				12.5*35	0.039	2710						
910				18*20	0.048	1900						
1000	16*20	0.060	1600	16*25	0.042	2390						
1100	12.5*30	0.054	2230	12.5*40	0.035	2960						
1200	18*20	0.058	1830	16*30	0.041	2820						
1300	12.5*35	0.045	2570	18*25	0.038	2570						
1300	16*25	0.047	1900									
1300	18*20	0.047	1900									
1500												
1500												
1600	12.5*40	0.038	2700	16*35	0.032	3060						
1600	16*30	0.037	2660	18*30	0.034	2980						
1800	18*25	0.035	2350	16*40	0.031	3170						
2000												
2200	16*35	0.034	2830									
2200												
2300				18*35	0.029	3200						
2400	18*30	0.032	2690									
2700	16*40	0.030	3200	18*40	0.027	3560						
2700												
3000	18*35	0.030	3100									
3300												
3600	18*40	0.028	3290									



# VHX

- ◆ Low ESR, high capacity, miniaturized design, high ripple current tolerance, high reliability
- ◆ 105°C, 2000~5000 hours
- ◆ Meets vibration resistance requirements
- ◆ Surface mount type, suitable for high-temperature lead-free reflow soldering
- ◆ Compliant with AEC-Q200, RoHS compliant



## Main technical parameters

project	characteristic	
Operating temperature range	- 55 ~ +105°C	
Rated operating voltage	16 ~ 100V	
Capacity range	6.8 ~ 1500μF 120Hz 20°C	
Capacity tolerance	±20% (120Hz 20°C)	
Loss tangent	120Hz 20°C	
Leakage current	Below 0.01CV (μA), charge for 2 minutes at rated voltage, 20°C	
Equivalent series resistance (ESR)	The following are the values from the standard sample list: 100kHz, 20°C	
Temperature characteristics	Z(-25°C)/Z(+20°C) ≤ 2.0 ; Z(-55°C)/Z(+20°C) ≤ 2.5 (100kHz)	
Durability	After applying the rated voltage with rated ripple current at 105°C for 2000H/5000H, and then placing it at 20°C for 16 hours, the product should meet the following requirements.	
	Guaranteed lifespan	ΦD ≤ 6.3mm: 2000小时 ΦD ≥ 8mm: 5000小时
	Capacitance change rate	±30% of the initial value
	Equivalent series resistance (ESR)	≦ 200% of the initial specification value
	Loss tangent	≦ 200% of the initial specification value
	Leakage current	≦ Initial specification value
High temperature storage	After storage at 105°C for 1000 hours, followed by a 16-hour period at room temperature (20°C ± 2°C), the product should meet the following requirements.	
	Rate of change of capacitance	±30% of the initial value
	Equivalent series resistance (ESR)	≦ 200% of the initial specification value
	Loss tangent	≦ 200% of the initial specification value
	Leakage current	≦ Initial specification value
High temperature and humidity	After being subjected to rated voltage for 1000 hours at 85°C and 85% RH, and then placed at 20°C for 16 hours, the product should meet the following requirements.	
	Rate of change of capacitance	±30% of the initial value
	Equivalent series resistance (ESR)	≦ 200% of the initial specification value
	Loss tangent	≦ 200% of the initial specification value
	Leakage current	≦ Initial specification value

※ If there is any doubt about the leakage current value, please place the product at 105°C and apply the rated operating voltage for 2 hours, then cool it down to 20°C before testing the leakage current.

## Product dimension drawing (unit: mm)

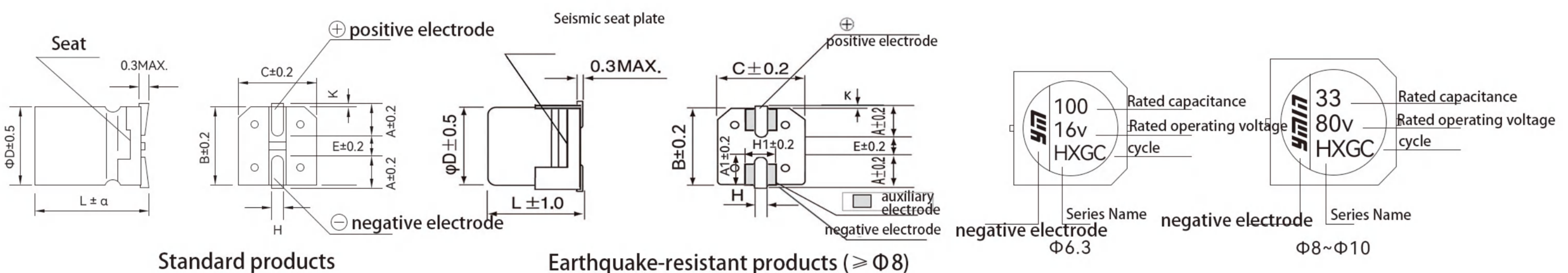

ΦD	B	C	A	A1	H	H1	E	K	α
5	5.3	5.3	2.1	/	0.65±0.20	/	1.3	0.5MAX	±0.5
6.3	6.6(7.0)	6.6	2.6	1.3	0.70±0.20	2.5	1.8	0.5MAX	
8	8.3(8.8)	8.3	3.0	1.8	0.90±0.20	3.9	3.1	0.5MAX	
10	10.3(10.8)	10.3	3.5	1.8	0.90±0.20	3.9	4.6	0.70±0.20	±1.0
12.5	12.8(13.5)	12.8	4.7	2.5	0.90±0.20	4.4	4.6	0.70±0.30	

## Frequency correction factor

Capacitance C	Frequency (Hz)	120Hz	500Hz	1kHz	5kHz	10kHz	20kHz	40kHz	100kHz	200kHz	500kHz
C < 47μF	Correction factor	0.12	0.20	0.35	0.50	0.65	0.70	0.80	1.00	1.00	1.05
47μF ≤ C < 120μF		0.15	0.30	0.45	0.60	0.75	0.80	0.85	1.00	1.00	1.00
C ≥ 120μF		0.15	0.30	0.45	0.65	0.80	0.85	0.85	1.00	1.00	1.00

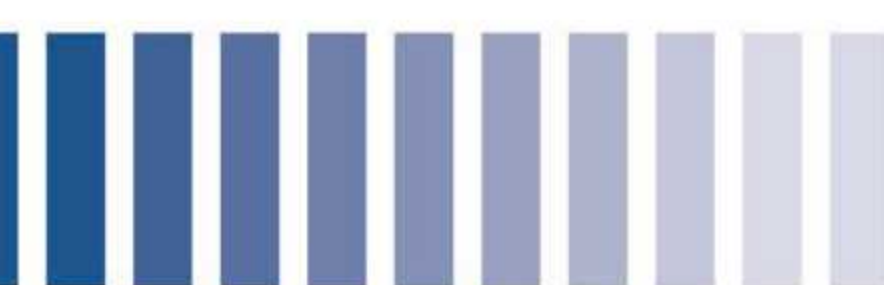

PROJECT	MARK	Φ3.55/Φ4		Φ5				Φ6.3/Φ7			Φ8		Φ10	Φ12.5	Φ13	ERROR
		U7	T8	U1	U4	U5	T1	U2	U6	T2	U3	T3	T4	T5		
LEAD WIRE PROCESSING MARKINGS		U7	T8	U1	U4	U5	T1	U2	U6	T2	U3	T3	T4	T5		
SHAPE AND DIMENSION DIAGRAM		Figure A	Figure B	Figure A	Figure A	Figure A	Figure B	Figure A	Figure A	Figure B	Figure A	Figure B	Figure B	Figure B		
LEAD WIRE DIAMETER	Φd	0.45		0.5				0.5/0.6		0.6					±0.05	
MAIN BODY SPACING	P	12.7											15	±1.0		
PERFORATION SPACING	P0	12.7											15	±0.2		
PERFORATION AND LEAD WIRE SPACING	P1	5.1	5.6	3.85	5.1	4.6	5.35	3.85	4.6	5.1	3.85	4.6	3.85	5.0	±0.7	
PERFORATION AND MAIN BODY SPACING	P2	6.35											7.5	±1.0		
LEAD WIRE SPACING	F1	2.5	5.0	5.0	2.5	3.5	5.0	5.0	3.5	5.0	5.0	5.0	5.0	+0.8~-0.2		
LEAD WIRE SPACING	F	1.5		2.0			2.5		3.5		5.0				±0.5	
BACKING PAPER WIDTH	W	18.0											±0.3			
TAPE WIDTH	W0	12.5											MIN			
PERFORATION AND BACKING PAPER SPACING	W1	9.0											±0.5			
TAPE AND BACKING PAPER SPACING	W2	2.0~3.0						0.5~2.0					/			
LOWER BODY POSITION	H	18.5											±0.75			
LEAD WIRE BENDING HEIGHT	H0	16	--	16		--	16	--	16	--					±0.5	
PERFORATION DIAMETER	ΦD0	4.0											±0.3			
MAIN BODY TILT ANGLE	Δh	1.0											MAX			
MAIN BODY TILT ANGLE	Δp	1.0											MAX			
TOTAL BRAIDING THICKNESS	t	0.6											±0.2			
PACKAGING QUANTITY		3000		2100				1700			984	672	440	420		

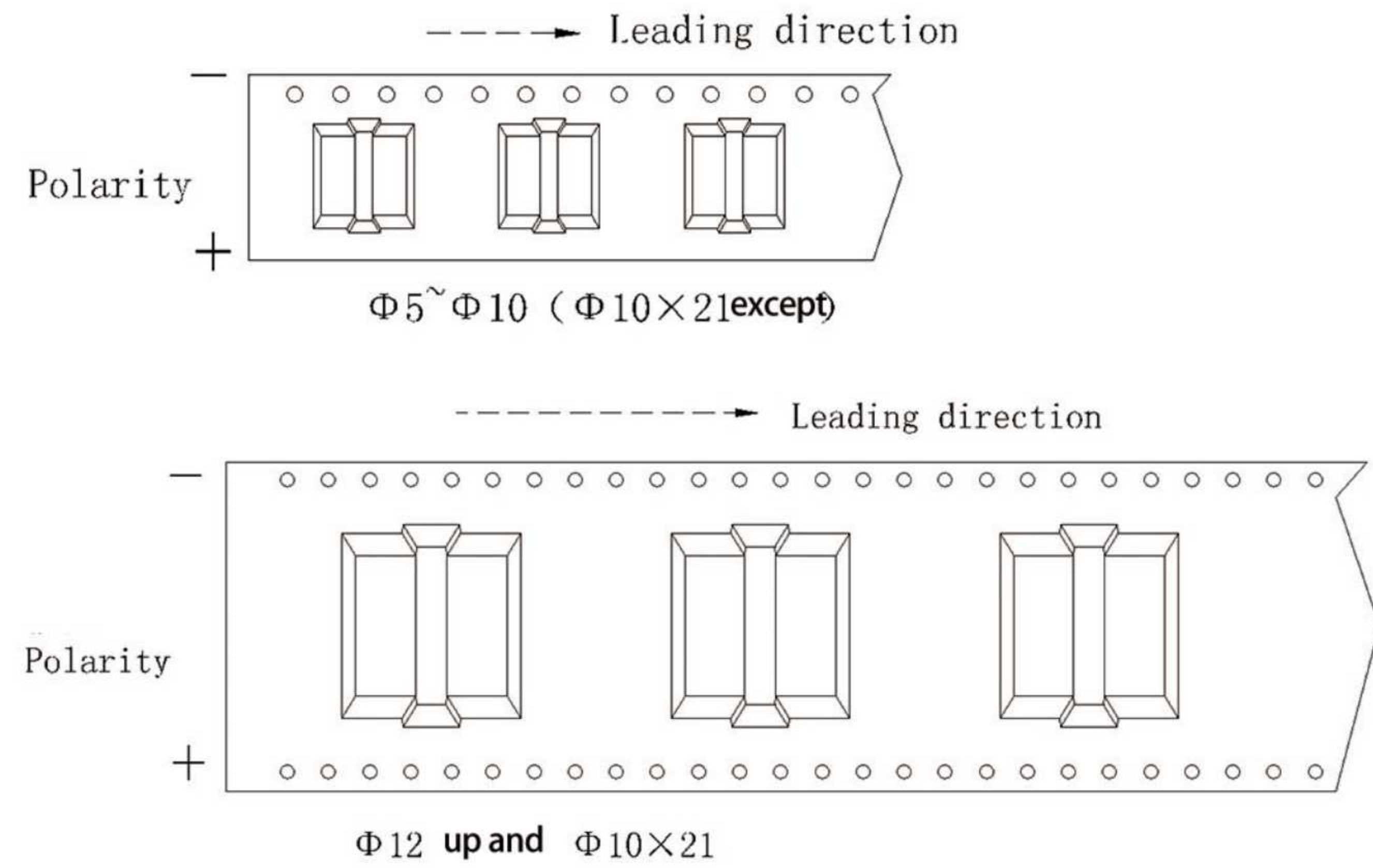
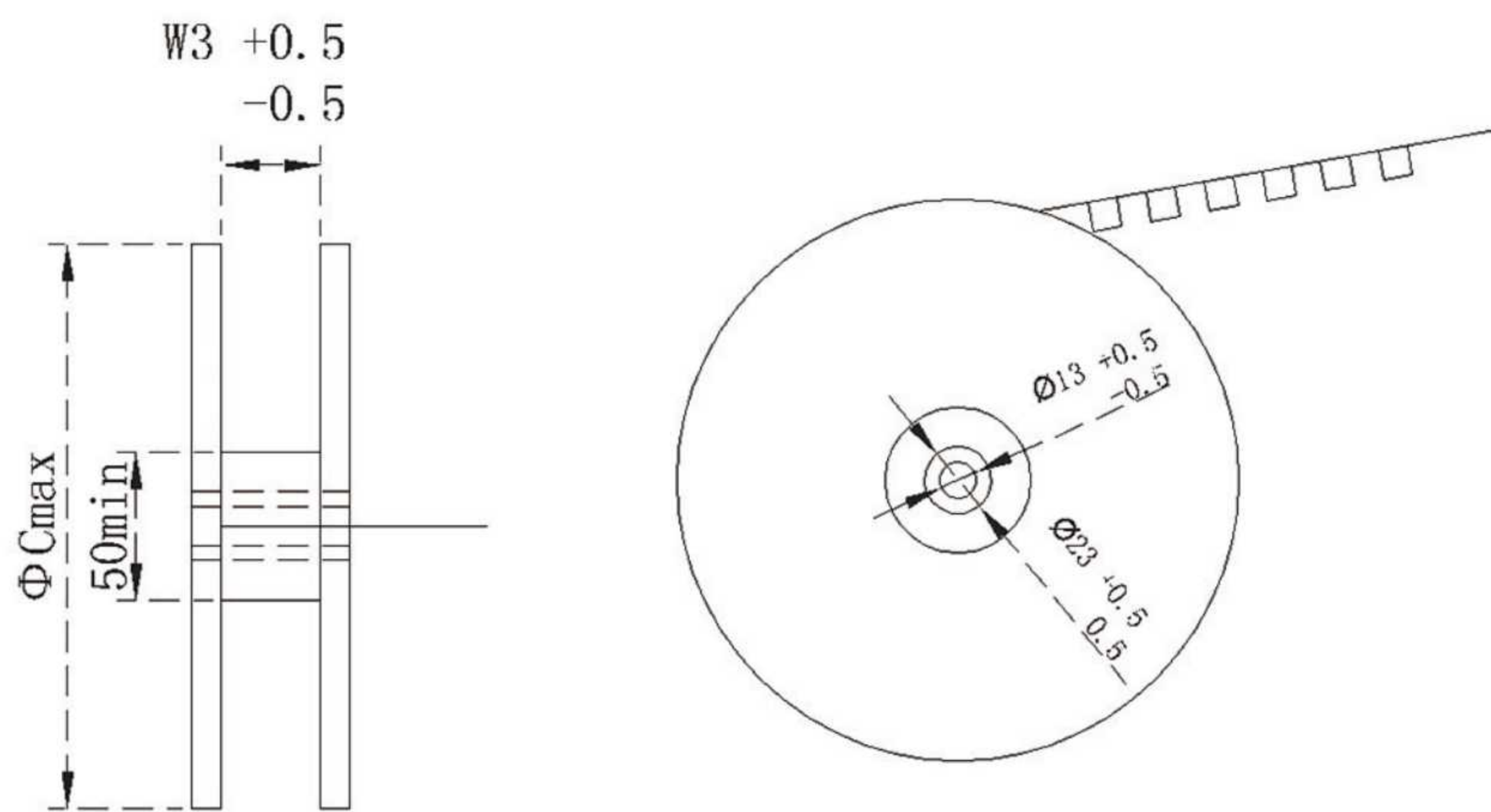
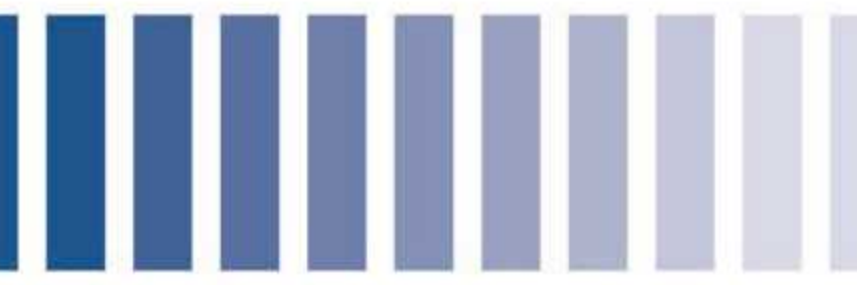

size	W3 (mm)	ΦC (mm)	Material tray / (pcs)	Inner box		Outer box	
				Number of trays (pieces)	Maximum packaging quantity: pcs/box	Number of inner boxes(pieces)	Maximum packaging quantity: pcs/box
Φ4×5.4~5.8	14	382	2000	8	16000	3	48000
Φ5×5.4~5.8,Φ5×5.7	14	382	1200	8	9600	3	28800
Φ4×7.7,Φ5×7.7~7.9,Φ5×8.5	18	382	900	6	5400	3	16200
Φ5×9.5,Φ5×10,Φ5.5×9	18	382	700	6	4200	3	12600
Φ5×11,Φ5×12,Φ5×13	18	382	500	6	3000	3	9000
Φ5×15.5,Φ5.5×15.5	18	382	350	6	1750	3	5250
Φ6.3×3.95,Φ6.3×4.5	18	382	1500	6	9000	3	27000
Φ6.3×5.4~5.8,Φ6.3×6.1	18	382	1200	6	7200	3	21600
Φ6.3×7.7	18	382	900	6	5400	3	16200
Φ6.3×8,Φ6.3×8.5,Φ6.3×9	18	382	800	6	4800	3	14400
Φ6.3×9.5,Φ6.3×10	18	382	700	6	4200	3	12600
Φ6.3×11,Φ6.3×12,Φ6.3×13	18	382	500	6	3000	3	9000
Φ6.3×16.5	18	382	350	5	1750	3	5250
Φ8×5.7~6.2,Φ8×6.9	26	382	800	5	4000	3	12000
Φ8×7.7~7.9	26	382	600	5	3000	3	9000
Φ8×8.5,Φ8×9,Φ8×10.5	26	382	500	5	2500	3	7500
Φ8×11,Φ8×11.5,Φ8×12.5	26	382	400	5	2000	3	6000
Φ8×13.5	26	382	400	5	2000	3	6000
Φ8×14.5,Φ8×15	26	382	350	5	1750	3	5250
Φ8×16.5,Φ8×17,Φ8×18	26	382	350	5	1750	3	5250
Φ8×20.5	26	382	175	5	875	3	2625
Φ10×5.7~6.9,Φ10×6.7	26	382	800	5	4000	3	12000
Φ10×7.7~8.4,Φ10×7.5,Φ10×8.5	26	382	600	5	3000	3	9000
Φ10×9,Φ10×10,Φ10×10.5	26	382	500	5	2500	3	7500
Φ10×12,Φ10×13.5,Φ10×14	26	382	400	5	2000	3	6000
Φ10×14.5,Φ10×15	26	382	350	5	1750	3	5250
Φ10×16.5,Φ10×17,Φ10×18	26	382	300	5	1500	3	4500
Φ10×19,Φ10×21,Φ10×22	34	382	175	4	700	3	2100
Φ12.5×10,Φ12.5×12,Φ12.5×13,Φ12.5×13.5,Φ12.5×14,Φ12.5×15	34	382	250	4	1000	3	3000
Φ12.5×16,Φ12.5×16.5,Φ12.5×17	34	382	200	4	800	3	2400
Φ12.5×18.5,Φ12.5×19,Φ12.5×21	34	382	175	4	700	3	2100
Φ16×16.5,Φ16×17	46	382	150	3	450	3	1350
Φ16×21.5(21)	46	382	120	3	360	3	1080
Φ18×16.5	46	382	150	3	450	3	1350
Φ18×21.5(21)	46	382	120	3	360	3	1080

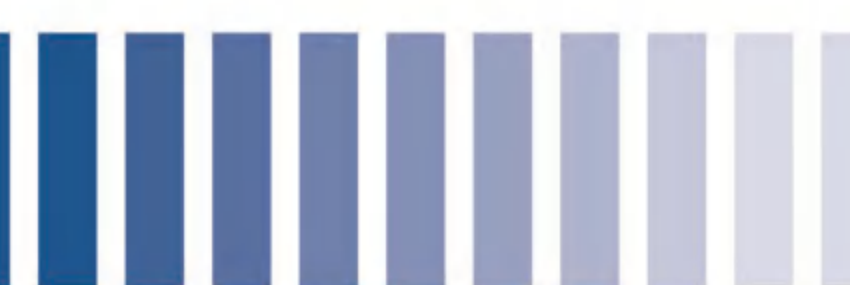

# VHX

## ■ List of Standard Products

Rated voltage (V)	nominal capacity (μF)	size ΦD×L(mm)	Tan δ 120Hz	ESR (mΩ100kHz)	Rated ripple current (mA r.m.s./105°C100kHz)	model	
						Standard products	earthquake-resistant products
6.3(7.2)	680	6.3×9.5	0.16	25	2400	VHXC0950J681MVCG	VHXC0950J681MVKZ
10(11.5)	47	5×5.8	0.16	60	1400	VHXB0581A470MVCG	---
10(11.5)	330	6.3×5.8	0.16	45	1600	VHXC0581A331MVCG	VHXC0581A331MVKZ
10(11.5)	470	8×10.5	0.16	22	2500	VHXD1051A471MVCG	VHXD1051A471MVKZ
16(18.4)	47	6.3×5.8	0.16	45	1600	VHXC0581C470MVCG	VHXC0581C470MVKZ
16(18.4)	100	5×5.8	0.16	60	1400	VHXB0581C101MVCG	---
16(18.4)	100	6.3×5.8	0.16	45	1600	VHXC0581C101MVCG	VHXC0581C101MVKZ
16(18.4)	150	6.3×5.8	0.16	45	1600	VHXC0581C151MVCG	VHXC0581C151MVKZ
16(18.4)	150	6.3×7.7	0.16	27	2200	VHXC0771C151MVCG	VHXC0771C151MVKZ
16(18.4)	220	6.3×5.8	0.16	45	1600	VHXC0581C221MVCG	VHXC0581C221MVKZ
16(18.4)	270	6.3×7.7	0.16	27	2200	VHXC0771C271MVCG	VHXC0771C271MVKZ
16(18.4)	330	6.3×8.5	0.16	27	2300	VHXC0851C331MVCG	VHXC0851C331MVKZ
16(18.4)	470	8×10.5	0.16	22	2500	VHXD1051C471MVCG	VHXD1051C471MVKZ
16(18.4)	680	8×10.5	0.16	22	2500	VHXD1051C681MVCG	VHXD1051C681MVKZ
16(18.4)	680	10×10.5	0.16	18	2600	VHXE1051C681MVCG	VHXE1051C681MVKZ
16(18.4)	1000	10×10.5	0.16	18	2600	VHXE1051C102MVCG	VHXE1051C102MVKZ
16(18.4)	1000	10×13	0.16	15	3200	VHXE1301C102MVCG	VHXE1301C102MVKZ
16(18.4)	1500	10×13	0.17	15	3200	VHXE1301C152MVCG	VHXE1301C152MVKZ
25(28.8)	82	6.3×5.8	0.14	50	1300	VHXC0581E820MVCG	VHXC0581E820MVKZ
25(28.8)	100	5×5.8	0.14	80	1150	VHXB0581E101MVCG	---
25(28.8)	100	6.3×7.7	0.14	30	2200	VHXC0771E101MVCG	VHXC0771E101MVKZ
25(28.8)	150	5×7.7	0.14	60	1250	VHXB0771E151MVCG	---
25(28.8)	150	6.3×5.8	0.14	50	1300	VHXC0581E151MVCG	VHXC0581E151MVKZ
25(28.8)	150	6.3×7.7	0.14	30	2000	VHXC0771E151MVCG	VHXC0771E151MVKZ
25(28.8)	220	6.3×5.8	0.14	50	1300	VHXC0581E221MVCG	VHXC0581E221MVKZ
25(28.8)	220	6.3×7.7	0.14	30	2000	VHXC0771E221MVCG	VHXC0771E221MVKZ
25(28.8)	330	8×10.5	0.14	27	2300	VHXD1051E331MVCG	VHXD1051E331MVKZ
25(28.8)	470	8×10.5	0.14	27	2300	VHXD1051E471MVCG	VHXD1051E471MVKZ
25(28.8)	470	10×10.5	0.14	20	2500	VHXE1051E471MVCG	VHXE1051E471MVKZ
25(28.8)	680	10×10.5	0.14	20	2500	VHXE1051E681MVCG	VHXE1051E681MVKZ
25(28.8)	680	10×13	0.14	16	3000	VHXE1301E681MVCG	VHXE1301E681MVKZ
25(28.8)	1000	10×13	0.14	16	3000	VHXE1301E102MVCG	VHXE1301E102MVKZ
35(41)	47	6.3×5.8	0.12	60	1300	VHXC0581V470MVCG	VHXC0581V470MVKZ
35(41)	68	5×7.7	0.12	80	1300	VHXB0771V680MVCG	---
35(41)	68	6.3×7.7	0.12	35	2000	VHXC0771V680MVCG	VHXC0771V680MVKZ
35(41)	100	6.3×5.8	0.12	60	1300	VHXC0581V101MVCG	VHXC0581V101MVKZ
35(41)	120	5×11	0.12	60	1400	VHXB1101V121MVCG	---
35(41)	150	5×12	0.12	60	1450	VHXB1201V151MVCG	---
35(41)	150	6.3×7.7	0.12	35	2000	VHXC0771V151MVCG	VHXC0771V151MVKZ
35(41)	180	8×10.5	0.12	27	2300	VHXD1051V181MVCG	VHXD1051V181MVKZ
35(41)	220	5×15.5	0.12	40	1600	VHXB1551V221MVCG	---
35(41)	220	6.3×9.5	0.12	30	2250	VHXC0951V221MVCG	VHXC0951V221MVKZ
35(41)	220	8×7.7	0.12	40	1950	VHXD0771V221MVCG	VHXD0771V221MVKZ



# VHX

## ■ List of Standard Products

Rated voltage (浪涌电压) (V)	nominal capacity ( $\mu$ F)	size $\Phi$ D×L(mm)	Tan $\delta$ 120Hz	ESR (m $\Omega$ 100kHz)	Rated ripple current (mA r.m.s./105°C 100kHz)	model	
						Standard products	earthquake-resistant products
35(41)	220	8×9.5	0.12	30	2150	VHXD0951V221MVCG	VHXD0951V221MVKZ
35(41)	330	8×9.5	0.12	30	2150	VHXD0951V331MVCG	VHXD0951V331MVKZ
35(41)	330	8×10.5	0.12	27	2300	VHXD1051V331MVCG	VHXD1051V331MVKZ
35(41)	330	10×10.5	0.12	20	2500	VHXE1051V331MVCG	VHXE1051V331MVKZ
35(41)	470	10×10.5	0.12	20	2500	VHXE1051V471MVCG	VHXE1051V471MVKZ
35(41)	470	10×12.5	0.12	17	3000	VHXE1251V471MVCG	VHXE1251V471MVKZ
35(41)	470	10×13	0.12	17	3000	VHXE1301V471MVCG	VHXE1301V471MVKZ
35(41)	560	10×13	0.12	17	3000	VHXE1301V561MVCG	VHXE1301V561MVKZ
35(41)	680	10×13	0.12	17	3000	VHXE1301V681MVCG	VHXE1301V681MVKZ
35(41)	2200	12.5×21	0.14	16	4250	VHXL2101V222MVCG	VHXL2101V222MVKZ
50(58)	10	5×5.8	0.10	100	950	VHXB0581H100MVCG	---
50(58)	22	6.3×5.8	0.10	80	1100	VHXC0581H220MVCG	VHXC0581H220MVKZ
50(58)	33	6.3×7.7	0.10	40	1800	VHXC0771H330MVCG	VHXC0771H330MVKZ
50(58)	39	6.3×5.8	0.10	80	1100	VHXC0581H390MVCG	VHXC0581H390MVKZ
50(58)	56	6.3×7.7	0.10	40	1800	VHXC0771H560MVCG	VHXC0771H560MVKZ
50(58)	82	8×10.5	0.10	30	2100	VHXD1051H820MVCG	VHXD1051H820MVKZ
50(58)	100	8×10.5	0.10	30	2100	VHXD1051H101MVCG	VHXD1051H101MVKZ
50(58)	120	8×10.5	0.10	30	2100	VHXD1051H121MVCG	VHXD1051H121MVKZ
50(58)	120	10×9.5	0.10	25	2300	VHXE0951H121MVCG	VHXE0951H121MVKZ
50(58)	120	10×10.5	0.10	25	2300	VHXE1051H121MVCG	VHXE1051H121MVKZ
50(58)	180	10×13	0.10	19	2800	VHXE1301H181MVCG	VHXE1301H181MVKZ
50(58)	220	8×12.5	0.10	27	2250	VHXD1251H221MVCG	VHXD1251H221MVKZ
50(58)	220	10×10.5	0.10	25	2300	VHXE1051H221MVCG	VHXE1051H221MVKZ
50(58)	330	10×10.5	0.10	25	2300	VHXE1051H331MVCG	VHXE1051H331MVKZ
50(58)	330	10×13	0.10	19	2800	VHXE1301H331MVCG	VHXE1301H331MVKZ
50(58)	390	10×13	0.10	19	2800	VHXE1301H391MVCG	VHXE1301H391MVKZ
63(73)	15	6.3×5.8	0.08	100	1000	VHXC0581J150MVCG	VHXC0581J150MVKZ
63(73)	22	6.3×7.7	0.08	80	1500	VHXC0771J220MVCG	VHXC0771J220MVKZ
63(73)	27	6.3×5.8	0.08	100	1000	VHXC0581J270MVCG	VHXC0581J270MVKZ
63(73)	47	6.3×7.7	0.08	80	1500	VHXC0771J470MVCG	VHXC0771J470MVKZ
63(73)	56	8×10.5	0.08	40	1900	VHXD1051J560MVCG	VHXD1051J560MVKZ
63(73)	68	8×10.5	0.08	40	1900	VHXD1051J680MVCG	VHXD1051J680MVKZ
63(73)	100	8×10.5	0.08	40	1900	VHXD1051J101MVCG	VHXD1051J101MVKZ
63(73)	100	10×8.5	0.08	40	1850	VHXE0851J101MVCG	VHXE0851J101MVKZ
63(73)	100	10×10.5	0.08	30	2100	VHXE1051J101MVCG	VHXE1051J101MVKZ
63(73)	150	10×10.5	0.08	30	2100	VHXE1051J151MVCG	VHXE1051J151MVKZ
63(73)	150	10×13	0.08	20	2600	VHXE1301J151MVCG	VHXE1301J151MVKZ
63(73)	220	10×13	0.08	20	2600	VHXE1301J221MVCG	VHXE1301J221MVKZ
80(92)	8.2	6.3×5.8	0.08	120	900	VHXC0581K8R2MVCG	VHXC0581K8R2MVKZ
80(92)	10	6.3×5.8	0.08	120	900	VHXC0581K100MVCG	VHXC0581K100MVKZ
80(92)	12	6.3×7.7	0.08	100	1400	VHXC0771K120MVCG	VHXC0771K120MVKZ
80(92)	27	6.3×7.7	0.08	100	1400	VHXC0771K270MVCG	VHXC0771K270MVKZ
80(92)	33	8×10.5	0.08	45	1600	VHXD1051K330MVCG	VHXD1051K330MVKZ



# VHX

## ■ List of Standard Products

Rated voltage (V)	nominal capacity ( $\mu$ F)	size $\Phi$ D×L(mm)	Tan $\delta$ 120Hz	ESR (m $\Omega$ 100kHz)	Rated ripple current (mA r.m.s./105°C100kHz)	model	
						Standard products	earthquake-resistant products
80(92)	56	8×10.5	0.08	45	1600	VHXD1051K560MVCG	VHXD1051K560MVKZ
80(92)	56	10×10.5	0.08	35	1800	VHXE1051K560MVCG	VHXE1051K560MVKZ
80(92)	82	10×13	0.08	22	2300	VHXE1301K820MVCG	VHXE1301K820MVKZ
80(92)	100	10×10.5	0.08	35	1800	VHXE1051K101MVCG	VHXE1051K101MVKZ
80(92)	120	10×13	0.08	22	2300	VHXE1301K121MVCG	VHXE1301K121MVKZ
80(92)	330	12.5×21	0.08	30	3250	VHXL2101K331MVCG	VHXL2101K331MVKZ
80(92)	470	12.5×21	0.08	30	3250	VHXL2101K471MVCG	VHXL2101K471MVKZ
100(115)	6.8	6.3×5.8	0.08	120	900	VHXC0582A6R8MVCG	VHXC0582A6R8MVKZ
100(115)	8.2	6.3×7.7	0.08	100	1400	VHXC0772A8R2MVCG	VHXC0772A8R2MVKZ
100(115)	10	6.3×5.8	0.08	120	900	VHXC0582A100MVCG	VHXC0582A100MVKZ
100(115)	15	6.3×7.7	0.08	100	1400	VHXC0772A150MVCG	VHXC0772A150MVKZ
100(115)	22	8×10.5	0.08	50	1600	VHXD1052A220MVCG	VHXD1052A220MVKZ
100(115)	27	10×10.5	0.08	40	1800	VHXE1052A270MVCG	VHXE1052A270MVKZ
100(115)	33	8×10.5	0.08	50	1600	VHXD1052A330MVCG	VHXD1052A330MVKZ
100(115)	33	10×10.5	0.08	40	1800	VHXE1052A330MVCG	VHXE1052A330MVKZ
100(115)	47	10×10.5	0.08	40	1800	VHXE1052A470MVCG	VHXE1052A470MVKZ
100(115)	100	10×13	0.08	30	2000	VHXE1302A101MVCG	VHXE1302A101MVKZ
100(115)	150	12.5×14.5	0.08	30	2350	VHXL1452A151MVCG	VHXL1452A151MVKZ
100(115)	220	12.5×17	0.08	30	2450	VHXL1702A221MVCG	VHXL1702A221MVKZ
100(115)	270	18×16.5	0.08	20	2850	VHXJ1652A271MVCG	VHXJ1652A271MVKZ
100(115)	330	16×26.5	0.08	20	3450	VHXI2652A331MVCG	VHXI2652A331MVKZ



# VHT

- ◆ Low ESR, high tolerable ripple current, high reliability
- ◆ 125°C, 4000-hour warranty
- ◆ Meets vibration resistance requirements
- ◆ Surface mount type, suitable for high-temperature lead-free reflow soldering
- ◆ Compliant with AEC-Q200, RoHS compliant



## Main technical parameters

project	characteristic	
Operating temperature range	- 55 ~ +125°C	
Rated operating voltage	6.3 ~ 100V	
Capacity range	4.7 ~ 2200μF 120Hz 20°C	
Capacity tolerance	±20% (120Hz 20°C)	
Loss tangent	The following are the values from the standard product list: 120Hz, 20°C	
Leakage current	Below 0.01CV (μA), charge for 2 minutes at rated voltage, 20°C	
Equivalent series resistance (ESR)	The following are the values from the standard sample list: 100kHz, 20°C	
Temperature characteristics	Z(-25°C)/Z(+20°C) ≤ 2.0 ; Z(-55°C)/Z(+20°C) ≤ 2.5 (100kHz)	
Durability	After applying the rated voltage with rated ripple current at 105°C for 2000H/5000H, and then placing it at 20°C for 16 hours, the product should meet the following requirements.	
	Rate of change of capacitance	± 30% of the initial value
	Equivalent series resistance (ESR)	≦ 200% of the initial specification value
	Leakage current	≦ Initial specification value
High temperature storage	After storage at 105°C for 1000 hours, followed by a 16-hour period at room temperature (20°C ± 2°C), the product should meet the following requirements.	
	Rate of change of capacitance	± 30% of the initial value
	Equivalent series resistance (ESR)	≦ 200% of the initial specification value
	Leakage current	≦ Initial specification value
Note: Products stored at high temperatures must undergo voltage treatment.		
High temperature and humidity	After being subjected to rated voltage for 1000 hours at 85° C and 85% RH, and then placed at 20° C for 16 hours, the product should meet the following requirements.	
	Rate of change of capacitance	± 30% of the initial value
	Equivalent series resistance (ESR)	≦ 200% of the initial specification value
	Leakage current	≦ Initial specification value

※If there is any doubt about the leakage current value, please place the product at 105° C and apply the rated operating voltage for 2 hours, then cool it down to 20° C before testing the leakage current.

## Product dimension drawing (unit: mm)

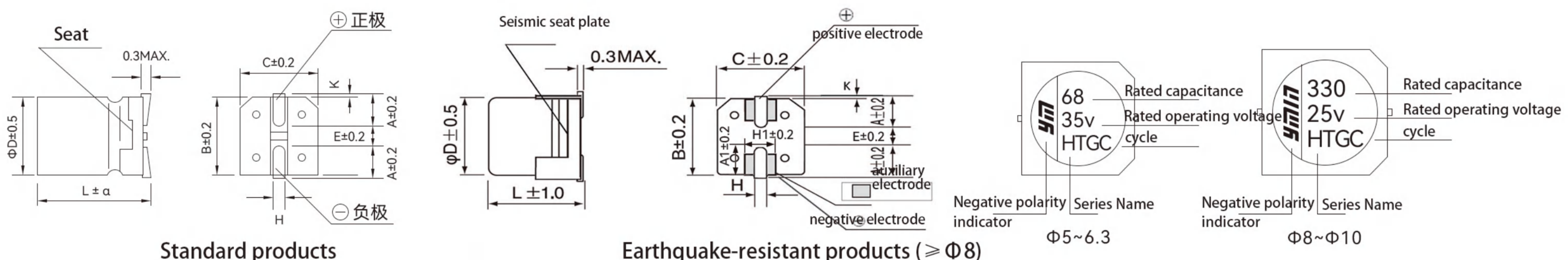

ΦD	B	C	A	A1	H	H1	E	K	α
5	5.3	5.3	2.1	/	0.65±0.20	/	1.3	0.5MAX	±0.5
6.3	6.6(7.0)	6.6	2.6	1.3	0.70±0.20	2.5	1.8	0.5MAX	
8	8.3(8.8)	8.3	3.0	1.8	0.90±0.20	3.9	3.1	0.5MAX	
10	10.3(10.8)	10.3	3.5	1.8	0.90±0.20	3.9	4.6	0.70±0.20	
12.5	12.8(13.5)	12.8	4.7	2.5	0.90±0.20	4.4	4.6	0.70±0.30	±1.0

## Frequency correction factor

Capacitance C	Frequency (Hz)	120Hz	500Hz	1kHz	5kHz	10kHz	20kHz	40kHz	100kHz	200kHz	500kHz
C < 47 μF	Correction factor	0.12	0.20	0.35	0.50	0.65	0.70	0.80	1.00	1.00	1.05
47 μF ≤ C < 120 μF		0.15	0.30	0.45	0.60	0.75	0.80	0.85	1.00	1.00	1.00
C ≥ 120 μF		0.15	0.30	0.45	0.65	0.80	0.85	0.85	1.00	1.00	1.00



# VHT

## ■ List of Standard Products

Rated voltage (V)	nominal capacity (μF)	size ΦD×L(mm)	Tan δ 120Hz	ESR (mΩ100kHz)	Rated ripple current (mA r.m.s./125°C100kHz)	model	
						Standard products	earthquake-resistant products
6.3(7.2)	100	5×5.8	0.16	80	550	VHTB0580J101MVCG	---
10(11.5)	47	6.3×5.8	0.16	45	950	VHTC0581A470MVCG	VHTC0581A470MVKZ
10(11.5)	100	5×5.8	0.16	80	550	VHTB0581A101MVCG	---
10(11.5)	220	6.3×5.8	0.16	45	950	VHTC0581A221MVCG	VHTC0581A221MVKZ
10(11.5)	470	6.3×7.7	0.16	27	1450	VHTC0771A471MVCG	VHTC0771A471MVKZ
16(18.4)	47	5×5.8	0.16	80	550	VHTB0581C470MVCG	---
16(18.4)	82	6.3×5.8	0.16	45	950	VHTC0581C820MVCG	VHTC0581C820MVKZ
16(18.4)	100	5×7.7	0.16	60	600	VHTB0771C101MVCG	---
16(18.4)	100	6.3×5.8	0.16	45	950	VHTC0581C101MVCG	VHTC0581C101MVKZ
16(18.4)	150	6.3×7.7	0.16	27	1450	VHTC0771C151MVCG	VHTC0771C151MVKZ
16(18.4)	220	6.3×5.8	0.16	45	950	VHTC0581C221MVCG	VHTC0581C221MVKZ
16(18.4)	270	6.3×7.7	0.16	27	1450	VHTC0771C271MVCG	VHTC0771C271MVKZ
16(18.4)	270	8×10.5	0.16	22	1700	VHTD1051C271MVCG	VHTD1051C271MVKZ
16(18.4)	470	10×10.5	0.16	18	3000	VHTE1051C471MVCG	VHTE1051C471MVKZ
16(18.4)	1200	10×13	0.17	16	3100	VHTE1301C122MVCG	VHTE1301C122MVKZ
16(18.4)	1800	10×17	0.17	12	4100	VHTE1701C182MVCG	VHTE1701C182MVKZ
25(28.8)	22	5×5.8	0.14	80	550	VHTB0581E220MVCG	---
25(28.8)	33	5×5.8	0.14	80	550	VHTB0581E330MVCG	---
25(28.8)	33	6.3×5.8	0.14	50	900	VHTC0581E330MVCG	VHTC0581E330MVKZ
25(28.8)	47	6.3×5.8	0.14	50	900	VHTC0581E470MVCG	VHTC0581E470MVKZ
25(28.8)	56	5×5.8	0.14	80	550	VHTB0581E560MVCG	---
25(28.8)	56	6.3×5.8	0.14	50	900	VHTC0581E560MVCG	VHTC0581E560MVKZ
25(28.8)	68	6.3×7.7	0.14	30	1400	VHTC0771E680MVCG	VHTC0771E680MVKZ
25(28.8)	100	6.3×5.8	0.14	50	900	VHTC0581E101MVCG	VHTC0581E101MVKZ
25(28.8)	100	6.3×7.7	0.14	30	1400	VHTC0771E101MVCG	VHTC0771E101MVKZ
25(28.8)	150	6.3×7.7	0.14	30	1400	VHTC0771E151MVCG	VHTC0771E151MVKZ
25(28.8)	150	8×10.5	0.14	27	1600	VHTD1051E151MVCG	VHTD1051E151MVKZ
25(28.8)	180	8×8.5	0.14	30	1400	VHTD0851E181MVCG	VHTD0851E181MVKZ
25(28.8)	220	8×8.5	0.14	30	1400	VHTD0851E221MVCG	VHTD0851E221MVKZ
25(28.8)	220	8×10.5	0.14	27	1600	VHTD1051E221MVCG	VHTD1051E221MVKZ
25(28.8)	270	8×10.5	0.14	27	1600	VHTD1051E271MVCG	VHTD1051E271MVKZ
25(28.8)	270	10×10.5	0.14	20	2800	VHTE1051E271MVCG	VHTE1051E271MVKZ
25(28.8)	330	10×10.5	0.14	20	2800	VHTE1051E331MVCG	VHTE1051E331MVKZ
25(28.8)	470	10×10.5	0.14	20	2800	VHTE1051E471MVCG	VHTE1051E471MVKZ
25(28.8)	470	10×13	0.14	16	3100	VHTE1301E471MVCG	VHTE1301E471MVKZ
25(28.8)	560	10×10.5	0.14	20	2800	VHTE1051E561MVCG	VHTE1051E561MVKZ
25(28.8)	560	10×13	0.14	16	3100	VHTE1301E561MVCG	VHTE1301E561MVKZ
25(28.8)	680	10×13	0.14	16	3100	VHTE1301E681MVCG	VHTE1301E681MVKZ
25(28.8)	820	10×13	0.14	16	3100	VHTE1301E821MVCG	VHTE1301E821MVKZ
25(28.8)	1000	10×17	0.14	12	4100	VHTE1701E102MVCG	VHTE1701E102MVKZ
35(41)	10	6.3×7.7	0.12	35	1400	VHTC0771V100MVCG	VHTC0771V100MVKZ
35(41)	22	5×5.8	0.12	100	550	VHTB0581V220MVCG	---
35(41)	27	6.3×5.8	0.12	60	900	VHTC0581V270MVCG	VHTC0581V270MVKZ

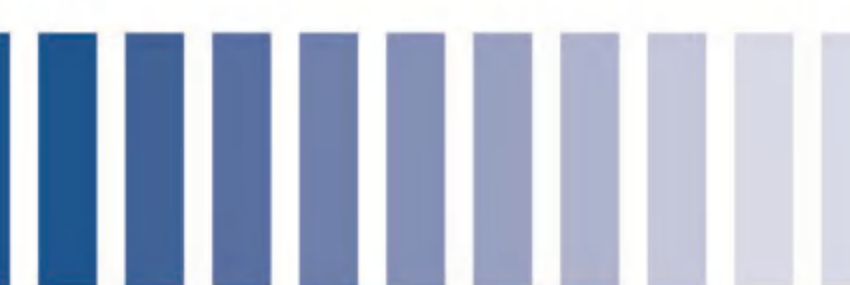

# VHT

## ■ List of Standard Products

Rated voltage (V)	nominal capacity (μF)	size ΦD×L(mm)	Tan δ 120Hz	ESR (mΩ100kHz)	Rated ripple current (mA r.m.s./125°C100kHz)	model	
						Standard products	earthquake-resistant products
35(41)	47	6.3×5.8	0.12	60	900	VHTC0581V470MVCG	VHTC0581V470MVKZ
35(41)	47	6.3×7.7	0.12	35	1400	VHTC0771V470MVCG	VHTC0771V470MVKZ
35(41)	47	8×10.5	0.12	27	1600	VHTD1051V470MVCG	VHTD1051V470MVKZ
35(41)	56	6.3×5.8	0.12	60	900	VHTC0581V560MVCG	VHTC0581V560MVKZ
35(41)	68	6.3×7.7	0.12	35	1400	VHTC0771V680MVCG	VHTC0771V680MVKZ
35(41)	100	6.3×7.7	0.12	35	1400	VHTC0771V101MVCG	VHTC0771V101MVKZ
35(41)	100	8×10.5	0.12	27	1600	VHTD1051V101MVCG	VHTD1051V101MVKZ
35(41)	100	10×10.5	0.12	20	2800	VHTE1051V101MVCG	VHTE1051V101MVKZ
35(41)	100	10×13	0.12	16	3000	VHTE1301V101MVCG	VHTE1301V101MVKZ
35(41)	120	6.3×7.7	0.12	35	1400	VHTC0771V121MVCG	VHTC0771V121MVKZ
35(41)	150	6.3×7.7	0.12	35	1400	VHTC0771V151MVCG	VHTC0771V151MVKZ
35(41)	150	8×10.5	0.12	27	1600	VHTD1051V151MVCG	VHTD1051V151MVKZ
35(41)	150	10×10.5	0.12	20	2800	VHTE1051V151MVCG	VHTE1051V151MVKZ
35(41)	180	8×10.5	0.12	27	1600	VHTD1051V181MVCG	VHTD1051V181MVKZ
35(41)	220	8×10.5	0.12	27	1600	VHTD1051V221MVCG	VHTD1051V221MVKZ
35(41)	270	10×10.5	0.12	20	2800	VHTE1051V271MVCG	VHTE1051V271MVKZ
35(41)	330	10×10.5	0.12	20	2800	VHTE1051V331MVCG	VHTE1051V331MVKZ
35(41)	390	10×10.5	0.12	20	2800	VHTE1051V391MVCG	VHTE1051V391MVKZ
35(41)	470	10×10.5	0.12	20	2800	VHTE1051V471MVCG	VHTE1051V471MVKZ
35(41)	470	10×13	0.12	16	3000	VHTE1301V471MVCG	VHTE1301V471MVKZ
35(41)	560	10×13	0.12	16	3000	VHTE1301V561MVCG	VHTE1301V561MVKZ
35(41)	680	10×13	0.12	16	3000	VHTE1301V681MVCG	VHTE1301V681MVKZ
35(41)	680	10×17	0.12	12	4100	VHTE1701V681MVCG	VHTE1701V681MVKZ
35(41)	820	12.5×13.5	0.12	16	3850	VHTL1351V821MVCG	VHTL1351V821MVKZ
35(41)	1000	12.5×15	0.12	16	4050	VHTL1501V102MVCG	VHTL1501V102MVKZ
35(41)	2200	18×21.5	0.14	16	5750	VHTJ2151V222MVCG	VHTJ2151V222MVKZ
50(58)	4.7	6.3×5.8	0.10	80	750	VHTC0581H4R7MVCG	VHTC0581H4R7MVKZ
50(58)	10	5×5.8	0.10	120	550	VHTB0581H100MVCG	---
50(58)	10	6.3×5.8	0.10	80	750	VHTC0581H100MVCG	VHTC0581H100MVKZ
50(58)	15	6.3×7.7	0.10	40	1100	VHTC0771H150MVCG	VHTC0771H150MVKZ
50(58)	22	6.3×5.8	0.10	80	750	VHTC0581H220MVCG	VHTC0581H220MVKZ
50(58)	33	6.3×7.7	0.10	40	1100	VHTC0771H330MVCG	VHTC0771H330MVKZ
50(58)	33	8×10.5	0.10	30	1250	VHTD1051H330MVCG	VHTD1051H330MVKZ
50(58)	47	6.3×7.7	0.10	40	1100	VHTC0771H470MVCG	VHTC0771H470MVKZ
50(58)	47	6.3×8.5	0.10	35	1150	VHTC0851H470MVCG	VHTC0851H470MVKZ
50(58)	47	6.3×10	0.10	40	1300	VHTC1001H470MVCG	VHTC1001H470MVKZ
50(58)	47	8×10.5	0.10	30	1250	VHTD1051H470MVCG	VHTD1051H470MVKZ
50(58)	47	10×10.5	0.10	25	1600	VHTE1051H470MVCG	VHTE1051H470MVKZ
50(58)	56	6.3×7.7	0.10	40	1100	VHTC0771H560MVCG	VHTC0771H560MVKZ
50(58)	56	10×10.5	0.10	25	1600	VHTE1051H560MVCG	VHTE1051H560MVKZ
50(58)	68	8×10.5	0.10	30	1250	VHTD1051H680MVCG	VHTD1051H680MVKZ
50(58)	100	8×10.5	0.10	30	1250	VHTD1051H101MVCG	VHTD1051H101MVKZ
50(58)	100	10×10.5	0.10	25	1600	VHTE1051H101MVCG	VHTE1051H101MVKZ

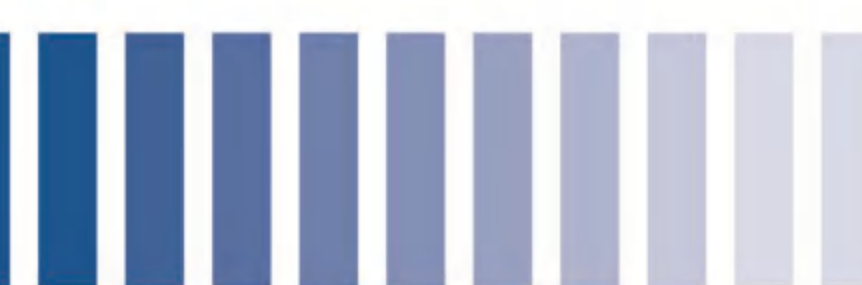

# VHT

## ■ List of Standard Products

Rated voltage (V)	nominal capacity (μF)	size ΦD×L(mm)	Tan δ 120Hz	ESR (mΩ100kHz)	Rated ripple current (mA r.m.s./125°C 100kHz)	model	
						Standard products	earthquake-resistant products
50(58)	100	10×17	0.10	12	3700	VHTE1701H101MVCG	VHTE1701H101MVKZ
50(58)	120	10×10.5	0.10	25	1600	VHTE1051H121MVCG	VHTE1051H121MVKZ
50(58)	150	10×10.5	0.10	25	1600	VHTE1051H151MVCG	VHTE1051H151MVKZ
50(58)	180	10×13	0.10	20	2400	VHTE1301H181MVCG	VHTE1301H181MVKZ
50(58)	220	10×12.5	0.10	20	2400	VHTE1251H221MVCG	VHTE1251H221MVKZ
50(58)	220	10×13	0.10	20	2400	VHTE1301H221MVCG	VHTE1301H221MVKZ
50(58)	220	10×13.5	0.10	20	2400	VHTE1351H221MVCG	VHTE1351H221MVKZ
50(58)	270	10×17	0.10	12	3700	VHTE1701H271MVCG	VHTE1701H271MVKZ
50(58)	330	10×15.5	0.10	30	3500	VHTE1551H331MVCG	VHTE1551H331MVKZ
50(58)	330	10×17	0.10	12	3700	VHTE1701H331MVCG	VHTE1701H331MVKZ
50(58)	330	12.5×13.5	0.10	20	3500	VHTL1351H331MVCG	VHTL1351H331MVKZ
63(73)	6.8	6.3×5.8	0.08	120	700	VHTC0581J6R8MVCG	VHTC0581J6R8MVKZ
63(73)	10	6.3×5.8	0.08	120	700	VHTC0581J100MVCG	VHTC0581J100MVKZ
63(73)	10	6.3×7.7	0.08	80	900	VHTC0771J100MVCG	VHTC0771J100MVKZ
63(73)	22	6.3×5.8	0.08	120	700	VHTC0581J220MVCG	VHTC0581J220MVKZ
63(73)	22	6.3×7.7	0.08	80	900	VHTC0771J220MVCG	VHTC0771J220MVKZ
63(73)	22	8×10.5	0.08	40	1100	VHTD1051J220MVCG	VHTD1051J220MVKZ
63(73)	33	8×10.5	0.08	40	1100	VHTD1051J330MVCG	VHTD1051J330MVKZ
63(73)	33	10×10.5	0.08	30	1400	VHTE1051J330MVCG	VHTE1051J330MVKZ
63(73)	47	8×8.5	0.08	50	950	VHTD0851J470MVCG	VHTD0851J470MVKZ
63(73)	47	8×10.5	0.08	40	1100	VHTD1051J470MVCG	VHTD1051J470MVKZ
63(73)	47	10×10.5	0.08	30	1400	VHTE1051J470MVCG	VHTE1051J470MVKZ
63(73)	56	10×10.5	0.08	30	1400	VHTE1051J560MVCG	VHTE1051J560MVKZ
63(73)	68	10×10.5	0.08	30	1400	VHTE1051J680MVCG	VHTE1051J680MVKZ
63(73)	82	10×10.5	0.08	30	1400	VHTE1051J820MVCG	VHTE1051J820MVKZ
63(73)	100	10×13	0.08	20	2200	VHTE1301J101MVCG	VHTE1301J101MVKZ
63(73)	150	10×13	0.08	20	2200	VHTE1301J151MVCG	VHTE1301J151MVKZ
63(73)	150	10×16.5	0.08	12	3500	VHTE1651J151MVCG	VHTE1651J151MVKZ
63(73)	150	10×17	0.08	12	3500	VHTE1701J151MVCG	VHTE1701J151MVKZ
63(73)	180	10×17	0.08	12	3500	VHTE1701J181MVCG	VHTE1701J181MVKZ
63(73)	220	10×17	0.08	12	3500	VHTE1701J221MVCG	VHTE1701J221MVKZ
80(92)	10	6.3×5.8	0.10	120	700	VHTC0581K100MVCG	VHTC0581K100MVKZ
80(92)	12	6.3×5.8	0.10	120	700	VHTC0581K120MVCG	VHTC0581K120MVKZ
80(92)	15	6.3×7.7	0.10	80	900	VHTC0771K150MVCG	VHTC0771K150MVKZ
80(92)	22	8×10.5	0.08	45	1100	VHTD1051K220MVCG	VHTD1051K220MVKZ
80(92)	33	10×10.5	0.10	35	1200	VHTE1051K330MVCG	VHTE1051K330MVKZ
80(92)	39	10×10.5	0.10	35	1200	VHTE1051K390MVCG	VHTE1051K390MVKZ
80(92)	47	8×10.5	0.08	45	1100	VHTD1051K470MVCG	VHTD1051K470MVKZ
80(92)	47	10×10.5	0.10	35	1200	VHTE1051K470MVCG	VHTE1051K470MVKZ
80(92)	68	10×10.5	0.10	35	1200	VHTE1051K680MVCG	VHTE1051K680MVKZ
80(92)	82	10×13	0.10	20	2200	VHTE1301K820MVCG	VHTE1301K820MVKZ
80(92)	100	8×17	0.08	30	1450	VHTD1701K101MVCG	VHTD1701K101MVKZ
80(92)	100	10×10.5	0.10	35	1200	VHTE1051K101MVCG	VHTE1051K101MVKZ

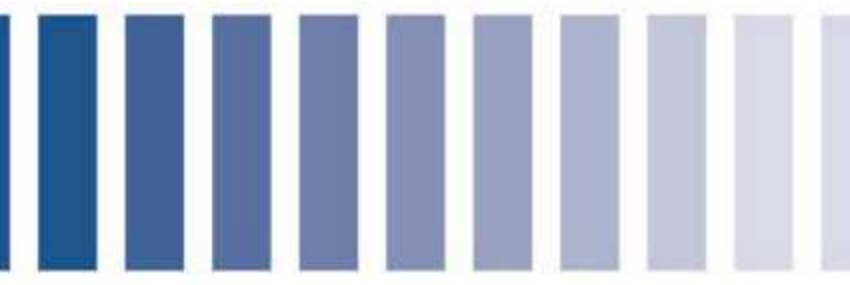

# VHT

## ■ List of Standard Products

Rated voltage (V)	nominal capacity (μF)	size ΦD×L(mm)	Tan δ 120Hz	ESR (mΩ100kHz)	Rated ripple current (mA r.m.s./125°C100kHz)	model	
						Standard products	earthquake-resistant products
80(92)	100	10×17	0.10	12	3500	VHTE1701K101MVCG	VHTE1701K101MVKZ
80(92)	120	10×17	0.10	12	3500	VHTE1701K121MVCG	VHTE1701K121MVKZ
80(92)	150	10×15.5	0.10	30	3300	VHTE1551K151MVCG	VHTE1551K151MVKZ
80(92)	150	12.5×13.5	0.10	20	3400	VHTL1351K151MVCG	VHTL1351K151MVKZ
80(92)	180	10×17	0.10	12	3500	VHTE1701K181MVCG	VHTE1701K181MVKZ
80(92)	220	12.5×17	0.10	20	3900	VHTL1701K221MVCG	VHTL1701K221MVKZ
80(92)	220	16×16.5	0.10	16	4350	VHTI1651K221MVCG	VHTI1651K221MVKZ
80(92)	270	12.5×19	0.10	20	4100	VHTL1901K271MVCG	VHTL1901K271MVKZ
80(92)	330	12.5×21	0.10	16	4300	VHTL2101K331MVCG	VHTL2101K331MVKZ
80(92)	470	16×21.5	0.10	16	4950	VHTI2151K471MVCG	VHTI2151K471MVKZ
100(115)	5.6	6.3×5.8	0.10	120	700	VHTC0582A5R6MVCG	VHTC0582A5R6MVKZ
100(115)	8.2	6.3×5.8	0.10	120	700	VHTC0582A8R2MVCG	VHTC0582A8R2MVKZ
100(115)	10	6.3×7.7	0.10	80	900	VHTC0772A100MVCG	VHTC0772A100MVKZ
100(115)	18	8×10.5	0.08	45	1100	VHTD1052A180MVCG	VHTD1052A180MVKZ
100(115)	22	8×10.5	0.08	45	1100	VHTD1052A220MVCG	VHTD1052A220MVKZ
100(115)	33	10×10.5	0.10	35	1200	VHTE1052A330MVCG	VHTE1052A330MVKZ
100(115)	47	10×10.5	0.10	35	1200	VHTE1052A470MVCG	VHTE1052A470MVKZ
100(115)	56	10×13	0.10	20	2200	VHTE1302A560MVCG	VHTE1302A560MVKZ
100(115)	82	10×17	0.10	12	3500	VHTE1702A820MVCG	VHTE1702A820MVKZ
100(115)	82	12.5×14.5	0.10	20	3500	VHTL1452A820MVCG	VHTL1452A820MVKZ
100(115)	120	12.5×15	0.10	20	3500	VHTL1502A121MVCG	VHTL1502A121MVKZ
100(115)	220	12.5×21	0.10	16	4100	VHTL2102A221MVCG	VHTL2102A221MVKZ

# VHR

- ◆ 150°C ultra-high temperature resistant product; 2000-hour warranty at 150°C
- ◆ Low ESR; high permissible ripple current; high reliability
- ◆ Compliant with AEC-Q200; RoHS compliant
- ◆ Meets vibration resistance requirements; surface mount type; suitable for high-temperature lead-free reflow soldering
- Main technical parameters



project	characteristic	
Operating temperature range	- 55 ~ +150°C	
Rated operating voltage	25 ~ 80V	
Capacity range	33 ~ 1800μF 120Hz 20°C	
Capacity tolerance	±20% (120Hz 20°C)	
Loss tangent	The following are the values from the standard product list: 120Hz, 20°C	
Leakage current	Below 0.01CV (μA), charge for 2 minutes at rated voltage, 20°C	
Equivalent series resistance (ESR)	The following are the values from the standard sample list: 100kHz, 20°C	
Temperature characteristics	$Z(-25^{\circ}\text{C})/Z(+20^{\circ}\text{C}) \leq 2.0$ ; $Z(-55^{\circ}\text{C})/Z(+20^{\circ}\text{C}) \leq 2.5$ (100kHz)	
Durability	After applying the rated voltage containing the rated ripple current at 150° C for a specified time, and then placing it at 20° C for 16 hours, the product should meet the following requirements.	
	Rate of change of capacitance	± 30% of the initial value
	Equivalent series resistance (ESR)	≦ 200% of the initial specification value
	Loss tangent	≦ 200% of the initial specification value
	Leakage current	≦ Initial specification value
High temperature storage	After storage at 105°C for 1000 hours, followed by a 16-hour period at room temperature (20°C ± 2°C), the product should meet the following requirements.	
	Rate of change of capacitance	± 30% of the initial value
	Equivalent series resistance (ESR)	≦ 200% of the initial specification value
	Loss tangent	≦ 200% of the initial specification value
	Leakage current	≦ Initial specification value
Note: Products stored at high temperatures must undergo voltage treatment.		
High temperature and humidity	After being subjected to rated voltage for 1000 hours at 85° C and 85% RH, and then placed at 20° C for 16 hours, the product should meet the following requirements.	
	Rate of change of capacitance	± 30% of the initial value
	Equivalent series resistance (ESR)	≦ 200% of the initial specification value
	Loss tangent	≦ 200% of the initial specification value
	Leakage current	≦ Initial specification value

※If there is any doubt about the leakage current value, please place the product at 105° C and apply the rated operating voltage for 2 hours, then cool it down to 20° C before testing the leakage current.

## Product dimension drawing (unit: mm)

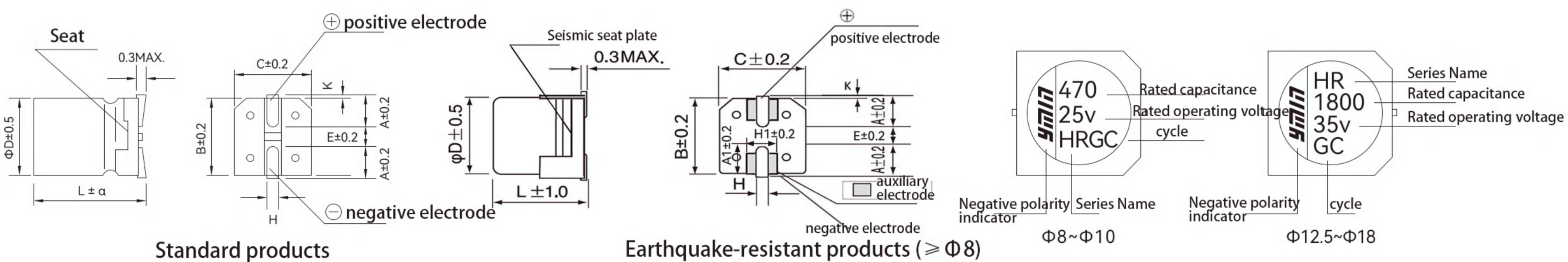

φD	B	C	A	A1	H	H1	E	K	α
6.3	6.6(7.0)	6.6	2.6	1.3	0.70±0.20	2.5	1.8	0.5MAX	±0.5
8	8.3(8.8)	8.3	3.0	1.8	0.90±0.20	3.9	3.1	0.5MAX	
10	10.3(10.8)	10.3	3.5	1.8	0.90±0.20	3.9	4.6	0.70±0.20	
12.5	12.8(13.5)	12.8	4.7	2.5	0.90±0.20	4.4	4.6	0.70±0.30	±1.0
16	17.0(17.5)	17	5.5	3.3	1.20±0.30	6.0	6.7	0.70±0.30	
18	19.0(19.5)	19	6.7	4.0	1.20±0.30	6.0	6.7	0.70±0.30	

## Frequency correction factor

Capacitance C	Frequency (Hz)	120Hz	500Hz	1kHz	5kHz	10kHz	20kHz	40kHz	100kHz	200kHz	500kHz
C < 47 μF 47 μF ≤ C < 120 μF C ≥ 120 μF	Correction factor	0.12	0.20	0.35	0.50	0.65	0.70	0.80	1.00	1.00	1.05
		0.15	0.30	0.45	0.60	0.75	0.80	0.85	1.00	1.00	1.00
		0.15	0.30	0.45	0.65	0.80	0.85	0.85	1.00	1.00	1.00



# VHR

## ■ List of Standard Products

Rated voltage (V)	nominal capacity (μF)	size ΦD×L(mm)	Tan δ 120Hz	ESR (mΩ100kHz)	Rated ripple current (mA r.m.s./125°C100kHz)	model	
						Standard products	earthquake-resistant products
25(28.8)	100	6.3×10.5	0.14	27	600	VHRC1051E101MVCG	VHRC1051E101MVKZ
25(28.8)	220	8×10.5	0.14	27	700	VHRD1051E221MVCG	VHRD1051E221MVKZ
25(28.8)	330	10×10.5	0.14	25	900	VHRE1051E331MVCG	VHRE1051E331MVKZ
25(28.8)	470	10×10.5	0.14	25	900	VHRE1051E471MVCG	VHRE1051E471MVKZ
25(28.8)	560	10×10.5	0.14	25	900	VHRE1051E561MVCG	VHRE1051E561MVKZ
25(28.8)	560	10×13	0.14	20	1050	VHRE1301E561MVCG	VHRE1301E561MVKZ
25(28.8)	1000	10×17	0.14	16	1200	VHRE1701E102MVCG	VHRE1701E102MVKZ
25(28.8)	1500	12.5×21.5	0.15	15	2500	VHRL2151E152MVCG	VHRL2151E152MVKZ
35(41)	120	8×10.5	0.12	27	700	VHRD1051V121MVCG	VHRD1051V121MVKZ
35(41)	220	10×10.5	0.12	25	900	VHRE1051V221MVCG	VHRE1051V221MVKZ
35(41)	330	10×10.5	0.12	25	900	VHRE1051V331MVCG	VHRE1051V331MVKZ
35(41)	330	10×13	0.12	20	1050	VHRE1301V331MVCG	VHRE1301V331MVKZ
35(41)	560	10×17	0.12	16	1200	VHRE1701V561MVCG	VHRE1701V561MVKZ
35(41)	1800	18×26.5	0.13	15	4000	VHRJ2651V182MVCG	VHRJ2651V182MVKZ
50(58)	47	6.3×10	0.10	40	500	VHRC1001H470MVCG	VHRC1001H470MVKZ
50(58)	82	8×10.5	0.10	30	600	VHRD1051H820MVCG	VHRD1051H820MVKZ
50(58)	120	10×10.5	0.10	28	800	VHRE1051H121MVCG	VHRE1051H121MVKZ
50(58)	180	10×12.5	0.10	25	1000	VHRE1251H181MVCG	VHRE1251H181MVKZ
50(58)	180	10×13	0.10	25	1000	VHRE1301H181MVCG	VHRE1301H181MVKZ
50(58)	330	12.5×17	0.10	30	1250	VHRL1701H331MVCG	VHRL1701H331MVKZ
50(58)	1800	18×31.5	0.11	18	5300	VHRJ3151H182MVCG	VHRJ3151H182MVKZ
63(73)	47	8×10.5	0.08	40	600	VHRD1051J470MVCG	VHRD1051J470MVKZ
63(73)	56	10×10.5	0.08	30	800	VHRE1051J560MVCG	VHRE1051J560MVKZ
63(73)	82	10×10.5	0.08	30	800	VHRE1051J820MVCG	VHRE1051J820MVKZ
63(73)	120	10×13	0.08	25	1000	VHRE1301J121MVCG	VHRE1301J121MVKZ
63(73)	180	10×17	0.08	20	1100	VHRE1701J181MVCG	VHRE1701J181MVKZ
63(73)	1200	18×31.5	0.09	20	5000	VHRJ3151J122MVCG	VHRJ3151J122MVKZ
80(92)	33	8×10.5	0.08	40	600	VHRD1051K330MVCG	VHRD1051K330MVKZ
80(92)	47	10×10.5	0.08	30	800	VHRE1051K470MVCG	VHRE1051K470MVKZ
80(92)	68	10×13	0.08	25	1000	VHRE1301K680MVCG	VHRE1301K680MVKZ
80(92)	100	10×13	0.08	25	1000	VHRE1301K101MVCG	VHRE1301K101MVKZ
80(92)	120	10×15.5	0.08	20	1050	VHRE1551K121MVCG	VHRE1551K121MVKZ
80(92)	150	10×17	0.08	30	1100	VHRE1701K151MVCG	VHRE1701K151MVKZ
80(92)	680	18×31.5	0.08	20	4700	VHRJ3151K681MVCG	VHRJ3151K681MVKZ

# NHX

- ◆ Low ESR, large capacity, miniaturized design, high ripple current tolerance, high reliability
- ◆ 105°C, 2000~5000-hour warranty
- ◆ Compliant with AEC-Q200
- ◆ RoHS compliant



## Main technical parameters

project	characteristic	
Operating temperature range	- 55 ~ +105°C	
Rated operating voltage	16 ~ 160V	
Capacity range	6.8 ~ 3300μF 120Hz 20°C	
Capacity tolerance	±20% (120Hz 20°C)	
Loss tangent	120Hz 20°C	
Leakage current	Below 0.01CV (μA), charge for 2 minutes at rated voltage, 20°C	
Equivalent series resistance (ESR)	The following are the values from the standard sample list: 100kHz, 20°C	
Temperature characteristics	Z(-25°C)/Z(+20°C) ≤ 2.0 ; Z(-55°C)/Z(+20°C) ≤ 2.5 (100kHz)	
Durability	After applying the rated voltage with rated ripple current at 105°C for 2000H/5000H, and then placing it at 20°C for 16 hours, the product should meet the following requirements.	
	Guaranteed lifespan	ΦD ≤ 6.3mm: 2000 hours ΦD ≥ 8mm: 5000 hours
	Capacitance change rate	± 30% of initial value
	Equivalent series resistance (ESR)	≤ 200% of initial specification value
	Leakage current	≤ Initial specification value
High temperature storage	After storage at 105°C for 1000 hours, followed by a 16-hour period at room temperature (20°C ± 2°C), the product should meet the following requirements.	
	Rate of change of capacitance	± 30% of the initial value
	Equivalent series resistance (ESR)	≤ 200% of the initial specification value
	Leakage current	≤ Initial specification value
High temperature and humidity	After being subjected to rated voltage for 1000 hours at 85°C and 85% RH, and then placed at 20°C for 16 hours, the product should meet the following requirements.	
	Rate of change of capacitance	± 30% of the initial value
	Equivalent series resistance (ESR)	≤ 200% of the initial specification value
	Leakage current	≤ Initial specification value

※ If there is any doubt about the leakage current value, please place the product at 105°C and apply the rated operating voltage for 2 hours, then cool it down to 20°C before testing the leakage current.

## Product dimension drawing (unit: mm)

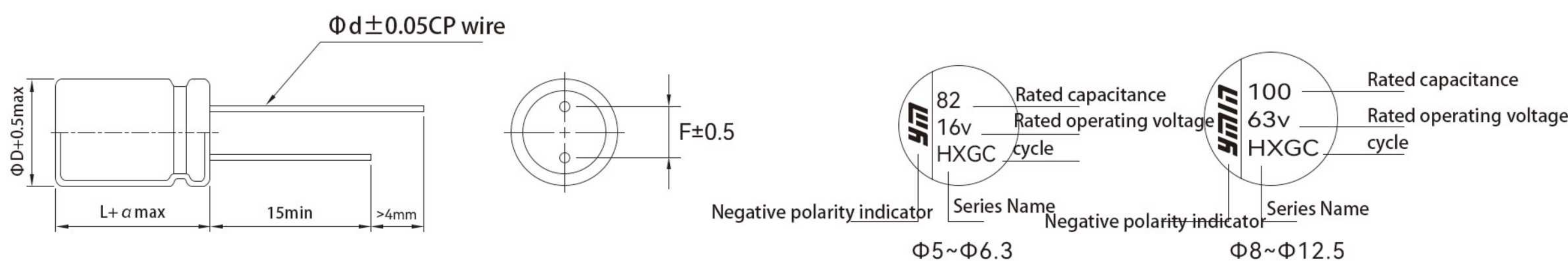

D (±0.5)	5	6.3	8	10	12.5	16	18
d (±0.05)	0.45/0.50	0.45/0.50	0.6	0.6	0.6	0.8	0.6
F (±0.5)	2	2.5	3.5	5	5	7.5	7.5
α	+0.5		+1				

## Frequency correction factor

Capacitance C	Frequency (Hz)	120Hz	500Hz	1kHz	5kHz	10kHz	20kHz	40kHz	100kHz	200kHz	500kHz
C < 47 μF	Correction factor	0.12	0.20	0.35	0.50	0.65	0.70	0.80	1.00	1.00	1.05
47 μF ≤ C < 120 μF		0.15	0.30	0.45	0.60	0.75	0.80	0.85	1.00	1.00	1.00
C ≥ 120 μF		0.15	0.30	0.45	0.65	0.80	0.85	0.85	1.00	1.00	1.00

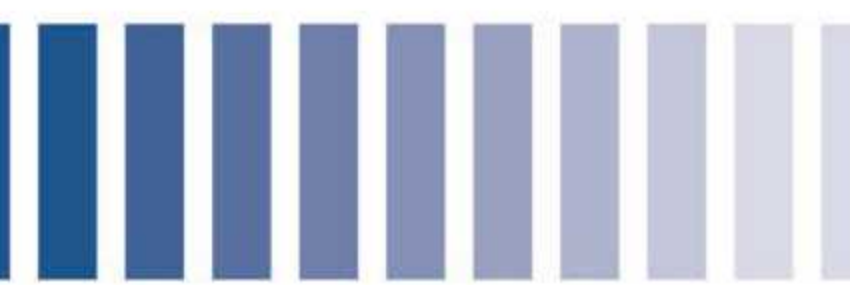

# NHX

## ■ List of Standard Products

Rated voltage (V)	nominal capacity (μF)	size ΦD×L(mm)	Tan δ 120Hz	ESR (mΩ100kHz)	Rated ripple current (mA r.m.s./105°C100kHz)
16(18.4)	100	5×5.7	0.16	60	1400
16(18.4)	100	6.3×5.7	0.16	45	1600
16(18.4)	150	6.3×7	0.16	27	2200
16(18.4)	220	6.3×5.7	0.16	45	1600
16(18.4)	220	6.3×7	0.16	27	2200
16(18.4)	270	6.3×7	0.16	27	2200
16(18.4)	470	8×10	0.16	22	2500
16(18.4)	680	8×10	0.16	22	2500
16(18.4)	680	10×10	0.16	18	2600
16(18.4)	1000	10×10	0.16	18	2600
16(18.4)	1000	10×12	0.16	15	3200
16(18.4)	1500	10×12	0.17	15	3200
25(28.8)	82	6.3×5.7	0.14	50	1300
25(28.8)	100	5×5.7	0.14	80	1150
25(28.8)	100	5×7	0.14	60	1250
25(28.8)	150	5×7	0.14	60	1250
25(28.8)	150	6.3×5.7	0.14	50	1300
25(28.8)	150	6.3×7	0.14	30	2000
25(28.8)	180	5×9	0.14	60	1400
25(28.8)	220	5×10	0.14	60	1400
25(28.8)	220	6.3×7	0.14	30	2000
25(28.8)	330	8×10	0.14	27	2300
25(28.8)	470	8×10	0.14	27	2300
25(28.8)	470	8×11	0.14	27	2300
25(28.8)	470	10×10	0.14	20	2500
25(28.8)	680	10×10	0.14	20	2500
25(28.8)	680	10×12	0.14	16	3000
25(28.8)	1000	10×12	0.14	16	3000
35(41)	47	6.3×5.7	0.12	60	1300
35(41)	68	6.3×7	0.12	35	2000
35(41)	100	6.3×5.7	0.12	60	1300
35(41)	150	6.3×7	0.12	35	2000
35(41)	180	8×10	0.12	27	2300
35(41)	220	6.3×9	0.12	30	2250
35(41)	330	8×10	0.12	27	2300
35(41)	330	10×10	0.12	20	2500
35(41)	470	10×9	0.12	20	2500
35(41)	470	10×10	0.12	20	2500
35(41)	470	10×12	0.12	17	3000
35(41)	680	10×12	0.12	17	3000
35(41)	3300	12.5×30	0.15	16	5000
50(58)	22	6.3×5.7	0.10	80	1100
50(58)	33	6.3×7	0.10	40	1800
50(58)	39	6.3×5.7	0.10	80	1100
50(58)	56	6.3×7	0.10	40	1800

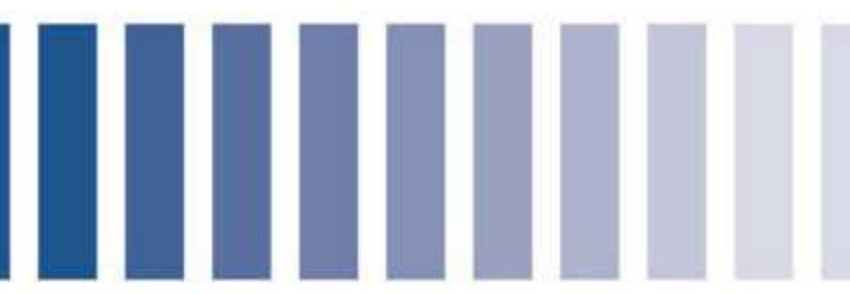

# NHX

## ■ List of Standard Products

Rated voltage (V)	nominal capacity (μF)	size ΦD×L(mm)	Tan δ 120Hz	ESR (mΩ100kHz)	Rated ripple current (mA r.m.s./105°C100kHz)
50(58)	82	8×10	0.10	30	2100
50(58)	120	8×10	0.10	30	2100
50(58)	120	10×10	0.10	25	2300
50(58)	180	10×12	0.10	19	2800
50(58)	220	10×10	0.10	25	2300
50(58)	330	10×12	0.10	19	2800
63(73)	15	6.3×5.7	0.08	100	1000
63(73)	22	6.3×7	0.08	80	1500
63(73)	27	6.3×5.7	0.08	100	1000
63(73)	47	6.3×7	0.08	80	1500
63(73)	56	8×10	0.08	40	1900
63(73)	100	8×10	0.08	40	1900
63(73)	100	10×10	0.08	30	2100
63(73)	150	10×10	0.08	30	2100
63(73)	150	10×12	0.08	20	2600
63(73)	220	10×12	0.08	20	2600
63(73)	1000	12.5×30	0.08	20	4400
80(92)	8.2	6.3×5.7	0.08	120	900
80(92)	10	6.3×5.7	0.08	120	900
80(92)	12	6.3×7	0.08	100	1400
80(92)	27	6.3×7	0.08	100	1400
80(92)	33	8×10	0.08	45	1600
80(92)	56	8×10	0.08	45	1600
80(92)	56	10×10	0.08	35	1800
80(92)	82	10×12	0.08	22	2300
80(92)	100	10×10	0.08	35	1800
80(92)	120	8×16	0.08	30	2000
80(92)	120	10×12	0.08	22	2300
80(92)	220	8×25	0.08	25	2500
100(115)	6.8	6.3×5.7	0.08	120	900
100(115)	8.2	6.3×7	0.08	100	1400
100(115)	10	6.3×5.7	0.08	120	900
100(115)	15	6.3×7	0.08	100	1400
100(115)	22	5×11	0.08	80	1100
100(115)	22	8×10	0.08	50	1600
100(115)	33	8×10	0.08	50	1600
100(115)	33	10×10	0.08	40	1800
100(115)	100	10×14	0.08	30	2100
100(115)	200	12.5×16	0.08	30	2450
100(115)	270	12.5×20	0.08	20	2700
100(115)	330	12.5×23	0.08	20	2850
120(138)	150	12.5×16	0.08	30	2450
120(138)	220	12.5×23	0.08	20	2850
160(184)	150	16×25	0.08	20	3450